

# Precision Tension and Compression Load Cell

## Model 8524

Code:	8524 EN
Delivery:	ex stock
Warranty:	24 months



Small measurement ranges



Medium measurement ranges



Large measurement ranges

**Optional  
overload protection  
up to the fivefold of  
measurement range**

- Measuring ranges from 0 ... 500 N to 0 ... 200 kN
- Measurement accuracy better than 0.25 % F.S.
- Output signal 1.5 mV/V, standardized
- Highly versatile and for universal use
- Type of protection acc. EN 60529 IP67 for measuring ranges  $\geq 0 \dots 20 \text{ kN}$
- Linearity error 0.1 % F.S. for measuring ranges  $\leq 0 \dots 5 \text{ kN}$  (option)
- Cable suitable for drag chains and highly flexible

### Application

Due to their compact design and construction, these tension-pressure load cells can be operated without any problems in laboratories as well as in industrial environments. Made of corrosion-resistant steel, these load cells can be integrated easily in existing structures, due to their standardized nominal characteristic value and simple assembly. Model 8524 can be used to measure static, semi-static and dynamic tension and compression forces depending on the measurement task.

Areas of application include:

- ▶ Measurement of press-in and insertion forces
- ▶ Measurement of spring forces
- ▶ Measurement of shearing and cutting forces
- ▶ Force measurement and control during assembly
- ▶ Measurement of pressure on drilling machines

A load-centering plate mounted on the load cell can be used to measure joint lugs, tension forces in ropes, chains, etc. (refer to page 4: load-centering plate).

### Description

The bending diaphragm inside the load cell is equipped with strain gauges which, on the exertion of a force, supply a bridge-output voltage directly proportional to the measurement variable. The center axis of the tension/compression load cells incorporates a continuous thread through which the measurement force is applied free from lateral or torsion force either using a load application button or an application-specific adapter part. Starting at a measurement range of 0 ... 5 kN, the measurement accuracy is ideal if the load cell has been mounted on a levelled, hard and polished base. This condition is not necessary for small measurement ranges of 0 ... 2 kN due to 3 special knife-edge bearings (see dimensional drawing 1).

Structural measures should be taken to avoid exposing the load cell to lateral forces (for instance, mounting on movable bearings, levers held by roller bearings). Attachment via the clearance bore holes integrated in the external ring allows simple handling of the sensor.

A stop serves as overload protection against damages caused by impermissible high compression forces (option up to measurement range 0 ... 20 kN). Lateral forces of up to 5 % nominal strength only have little influence.

**Technical Data**

Dim. tolerances acc. ISO 2768-f

Order Code	Measuring Range		Dimensions [mm]								Thread T	Number of Holes on $\varnothing G$	Natural Frequency [kHz]	Mass [kg]	Wrench for Mounting Screws 12.9	Designated Mounting Screws
			$\varnothing D1$	$\varnothing D2$	$\varnothing D3$	$\varnothing D4$	H	$\varnothing G$	$\varnothing X$	$\varnothing Y$						
8524-5500	0 ...	0.5 kN	54.5	15	35.5	33.5	16	45	4.5	8	M 8x1.25	3	> 2	0.25	3 Nm	M 4
8524-6001	0 ...	1 kN	54.5	15	35.5	33.5	16	45	4.5	8	M 8x1.25	3	> 3	0.25	3 Nm	M 4
8524-6002	0 ...	2 kN	54.5	15	35.5	33.5	16	45	4.5	8	M 8x1.25	3	> 5	0.25	3 Nm	M 4
8524-6005	0 ...	5 kN	54.5	15	35.5	34.5	16	45	4.5	8	M 8x1.25	6	> 8	0.25	3 Nm	M 4
8524-6010	0 ...	10 kN	54.5	15	35.5	34.5	16	45	4.5	8	M 8x1.25	6	> 12	0.25	3 Nm	M 4
8524-6020	0 ...	20 kN	79	22	59	58.6	25	68	4.5	8	M 12x1.5	8	> 4	0.65	3 Nm	M 4
8524-6050	0 ...	50 kN	119	44	94	92.6	35	105	6.6	11	M 24x1.5	8	> 3	2	10 Nm	M 6
8524-6100	0 ...	100 kN	155	60	109	107	50	129	13.5	20	M 36x3	8	> 3	5	100 Nm	M 12
8524-6200	0 ...	200 kN	155	60	109	107	50	129	13.5	20	M 36x3	8	> 5	5	100 Nm	M 12

**Electrical values**

Bridge resistance (full bridge): foil strain gauge 350  $\Omega$ , nominal\*  
 Excitation: max. 10 V DC or AC  
 Sensitivity: 1.5 mV/V  $\pm$  0.25 % positive output at compression

Calibration resistor (burster model 1148-6080): 80 k $\Omega$ ; 0.1 %  
 The bridge output signal resulting from a shunt of this value is shown in the calibration certificate. Calibration certificate includes the traceability verification of measuring equipment and is part of delivery.

\* Deviation from stated values are possible.

**Environmental conditions**

Temperature compensated: 15  $^{\circ}$ C ... 70  $^{\circ}$ C  
 Temperature operating: - 30  $^{\circ}$ C ... 80  $^{\circ}$ C  
 Temperature effect zero shift:  $\leq$  0.02 % F.S./K  
 Temperature effect span shift:  $\leq$  0.02 % Rdg./K

**Mechanical values**

Accuracy:  $\leq \pm$  0.25 % F.S.  
 Combined value consisting of non-linearity, hysteresis and non-repeatability in constant installation position.

Kind of measurement: Tension and compression  
 Load calibration in compression direction (preferential direction, output signal positive).  
 At use with tension load deviant output signal can be expected.

Deflection full scale: < 80  $\mu$ m  
 Overload safe: 150 % of capacity  
 Overload burst: > 250 % of capacity

Dynamic performance:  
 recommended 70 % of capacity  
 maximum 100 % of capacity

Material: stainless steel 1.4542

Protection class: acc. EN 60529 measuring range  $\leq$  0 ... 10 kN: IP65  
 measuring range  $\geq$  0 ... 20 kN: IP67

**Electrical termination:**

highly flexible, oil resistant, drag chains suitable, shielded cable with bare ends for soldering. Bending radius three times the diameter for fixed cable, ten times the diameter for cable permanently moving, length 2 m. Further details see dimensional drawing.

Cable model PUR,  $\varnothing$  4.2 mm

**Wiring code:**

white	excitation	positive
brown	excitation	negative
yellow	signal output	positive
green	signal output	negative

**Dimensions:**

see table dimensional drawing  
 Units with range  $\leq$  0 ... 2 kN are equipped with bearing edges within clearance holes. Therefore they are 1 mm higher.

**Assembly:**

measuring ranges up to 0 ... 2 kN: 3 clearance holes with edges for three-point-support (see dimension drawing 1)  
 measuring ranges from 0 ... 5 kN: 6 resp. 8 clearance holes (see dimensions drawing 2-4)

The entire bearing area of the sensor must be mounted on a base which is hardened (60 HRC), flat, polished or better lapped.

Counter bores in compliance with DIN 74-km, in compliance with DIN 912 head cap screws.

Mechanical strength of screws: 12.9 or better

Also refer to the accessories comprising load-centering plates and load introduction buttons, page 4.

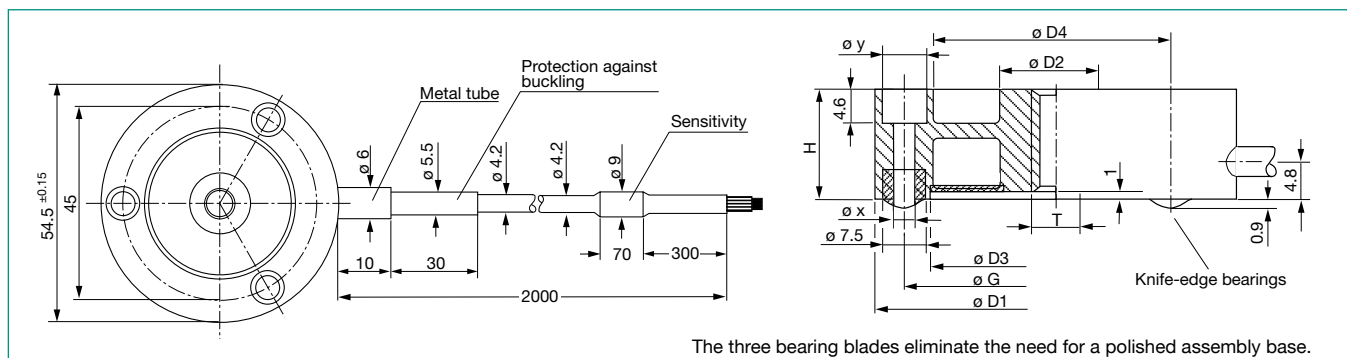
**Dimensional drawing 1** measuring range 0 ... 0.5 kN and 0 ... 2 kN

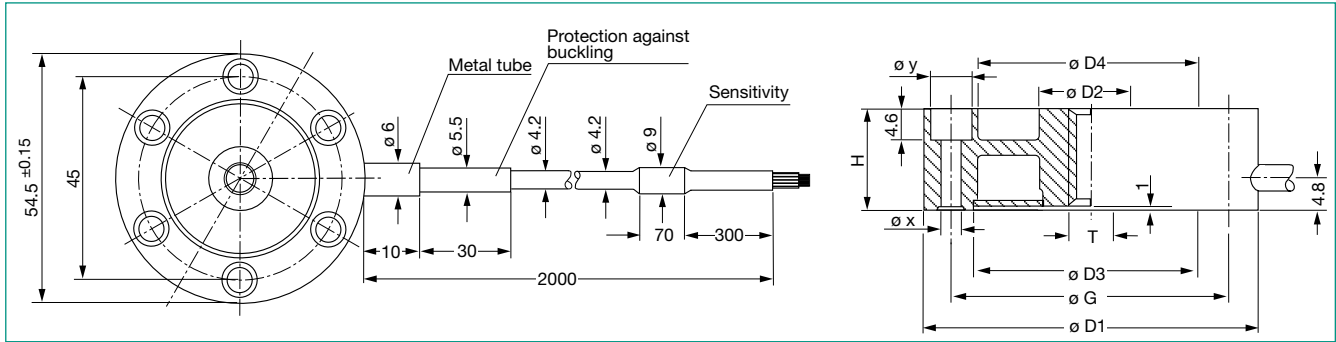
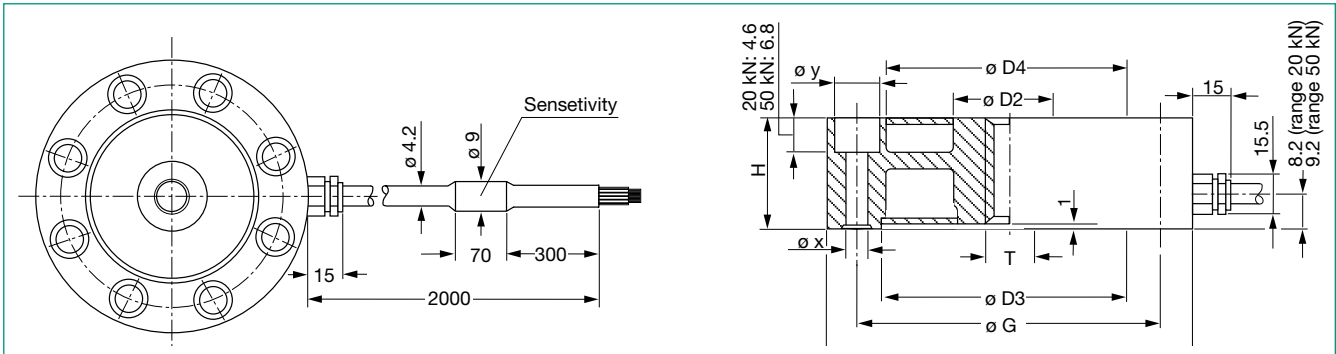
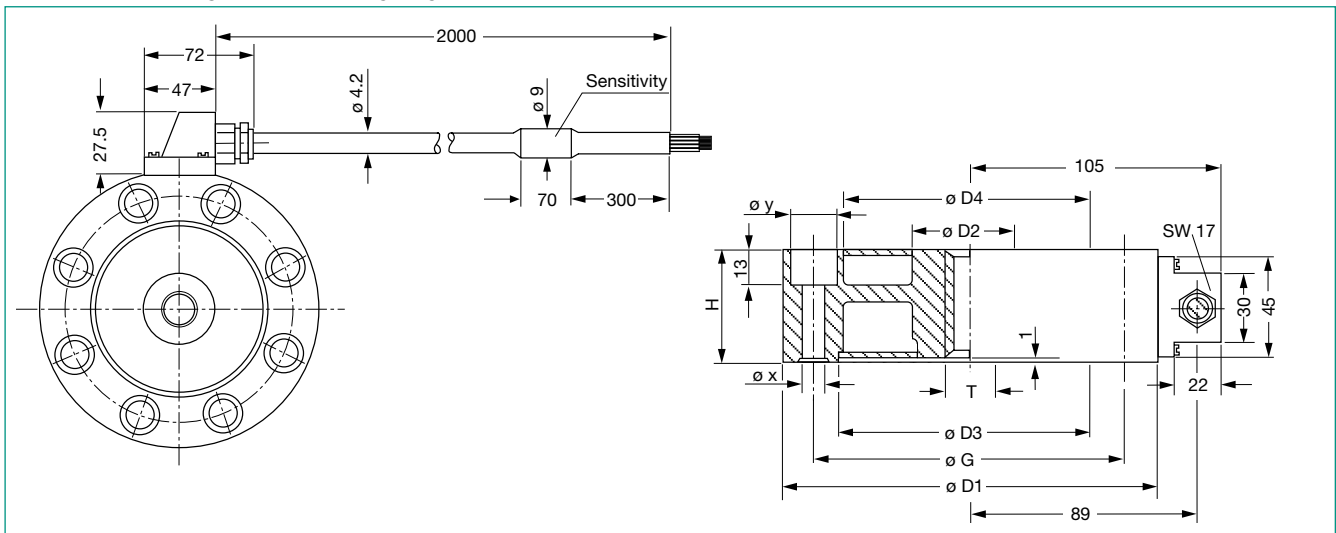
**Dimensional drawing 2** measuring ranges 0 ... 5 kN and 0 ... 10 kN

**Dimensional drawing 3** measuring ranges 0 ... 20 kN and 0 ... 50 kN

**Dimensional drawing 4** measuring ranges 0 ... 100 kN and 0 ... 200 kN

The CAD drawings (3D/2D) for this sensors can be imported online directly into your CAD system.

Download via [www.burster.com](http://www.burster.com) or directly at [www.traceparts.com](http://www.traceparts.com). For further information about the burster traceparts cooperation refer to data sheet 80-CAD-EN.

## Accessories

### Load buttons

load buttons for introducing compressive forces

Order Code	for Load Cell with Nominal Load	Dimensions [mm]						R	Tightening Torque	Mass [kg]
		øD	H	L	T	SW	R			
8580-V008	0.5 ... 10 kN	14	7.3	7	M 8 x 1.25	-	20	up to 2 kN: max. 5 Nm / 5 kN and 10 kN: max. 8 Nm	0.01	
8580-V012	20 kN	20	15.1	12	M 12 x 1.5	16	25		max. 10 Nm	0.05
8580-V024	50 kN	40	20	17	M 24 x 1.5	32	100	max. 20 Nm	0.25	
8580-V036	100 kN, 200 kN	57	30	40	M 36 x 3	46	200	max. 50 Nm	1	

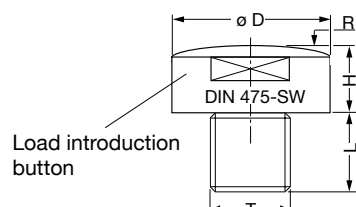

These load buttons prove extremely useful if a mechanical coupling (for instance, by means of a threaded rod) is not necessary or possible for a measurement of compressive forces. The spherical surface minimizes measurement errors in case of not axial force introduction.

The compression force needs to be introduced into the load button by means of a component with a plane surface, hardness  $\geq 60$  HRC. Calibration Certificates for compression load require a load button, which consequently is part of the load cell and must be ordered along with.

### Pull Plates

A pull plate extends the range of application of flat-design tension-pressure load cells to include the measurement of tensile forces in freely movable arrangements (rope tension, joint tension ...).

A pull plate has roughly the same dimensions as the sensor body and is mounted on the load cell (see drawing). The central tapped holes allow an installation of customer-specific or standard threaded components (for example, joint heads).

Order Code	for Nominal Load [kN]	Centric Thread	Mass [kg]	max. Wrench Torque for Screws 12.9
8590-V002	bis 10	M 8 x 1.25	0.28	3 Nm
8590-V003	20	M 12 x 1.5	0.70	3 Nm
8590-V004	50	M 24 x 1.5	2.2	10 Nm
8590-V005	100, 200	M 36 x 3	5.5	10 Nm

Screws of strength class 12.9 are required for attaching the pull plates to the load cells.

Mobile high-precision calibrator and testing device TRANS CAL 7281-V0001 with integrated strain gauge simulator for the compensation and calibration of indicators, measuring amplifiers and DIGIFORCE® measurement chains. In combination with a reference sensor it is possible to test, check and measure existing force, torque and pressure systems.

**Model 7281-V0001**

**Mating connection, 12 pins for burster desktop devices Model 9941**

**Mating connection, 9 pins for 9163-V3, 7281 and 9311**

**Model 9900-V209**

**Mating connection, 9 pins for 7281 and 9311 with TEDS**

**Model 9900-V229**

Mounting of mating connector on sensor cable upon prevalent use of the load cell

in preferential direction (output signal is positive in compressive direction)

**Order Code 99004**

only for connection to SENSORMASTER model 9163 desktop version

**Order Code 99002**

opposite to preferential direction (output signal is positive)

**Order Code 99007**

only for connection of the sensor to SENSORMASTER model 9163 desktop version

**Order Code 99008**

### Options

**Overload protection** compression direction (see drawing on the right)

**Order Code V400**

Load cell with option overload protection for compression direction						
Order Code	Measuring Range	Protected up to	Dimensions [mm]			
			øD1	H1	H	
8524-5500-V400	0 ... 500 N	2.5 kN	54.5	19	16	
8524-6001-V400	0 ... 1 kN	5 kN	54.5	19	16	
8524-6002-V400	0 ... 2 kN	10 kN	54.5	19	16	
8524-6005-V400	0 ... 5 kN	20 kN	54.5	19	16	
8524-6010-V400	0 ... 10 kN	30 kN	54.5	19	16	
8524-6020-V400	0 ... 20 kN	80 kN	79	25	25	

The overload protection protects the load cell against damages resulting from loads higher than the operating load value (150 % of the nominal load). The overload protection is realized through a dead stop limiting the displacement of the spring bellow upon load application to max. 130 % of the nominal load. The measurement of tension forces is possible also with mounted overload stop. For this reason the overload protection has the same external mounting bores as the sensor itself.

### Useful Information

- ▶ Overload protection for compression only.
- ▶ Overload protection mounting by factory only.
- ▶ Tolerance of standardized output of load cell at overload protection ± 0.5 %.
- ▶ Do not use the overload protection often.
- ▶ It is not allowed to introduce overload on load cell by thread (allowed are load buttons, see accessories or similar parts.)
- ▶ The overload protection does not have any centric threaded holes.

Standardized sensitivity, 1 mV/V ± 0.25 % - **V010**

Cable length 3 m - **V203**

Cable length 5 m - **V206**

Improved linearity error ± 0.1 % F.S.

(only for measurement ranges ≤ 0 ... 5 kN) - **V502**

### Sensor with pull plate

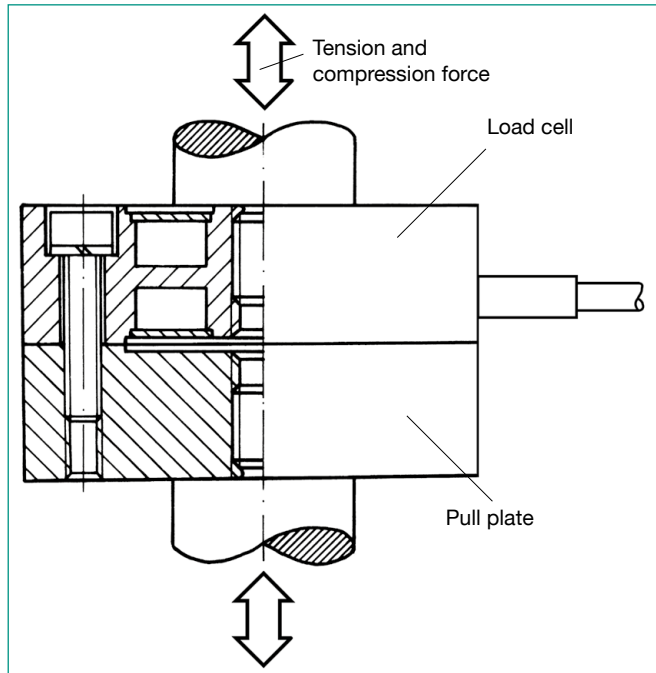

### Sensor with overload protection; available up to ≤ 0 ... 20 kN

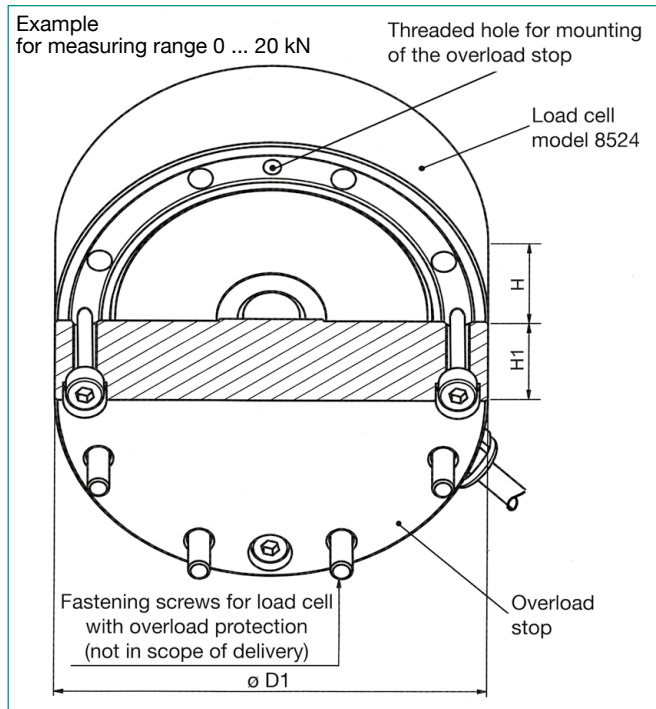

### Order Information

Tension and compression, range 0 ... 20 kN **Model 8524-6020**

Tension and compression, range 0 ... 5 kN,  
overload protection up to 20 kN **Model 8524-6005-V400**

### Signal conditioning

Digital indicator e.g. model 9180, amplifier e.g. model 9243 or DIGIFORCE® refer to section 9 of the catalog.

### Factory Calibration Certificate (WKS)

Calibration of a load cell separately as well as connected to an indicator. Standard is a certificate with 11 points, starting at zero, running up and down in 20% increments covering the complete measuring range for preferential direction. Special calibrations on request. Calculation of costs by base price plus additional costs per point.

**Order Code 85WKS-85...**