

Precision Miniature Load Cell

Models 8431, 8432 with Overload Protection

1. Introduction

The load cells in the model 8431 and 8432 series are primarily designed for the measurement of force in production equipment, using Newtons (N) as the unit of measurement.

The local gravitational acceleration ($g \approx 9.81 \text{ m/s}^2$) must be taken into account when determining masses.

2. Preparations for use

2.1 Unpacking

- Inspect the sensor carefully for damage.

If you suspect that the unit has been damaged during shipping, notify the delivery company within 72 hours. Keep all packaging materials for inspection by the representative of the manufacturer or delivery company.

- Only transport the model 8431 or 8432 sensors in their original packaging or in packaging of equivalent quality.

2.2 Using the instrument for the first time

- Only connect the sensor to instrumentation amplifiers that are fitted with a safety transformer according to EN 61558.

Note:

Transmitters connected to the outputs or other devices that are galvanically connected to the sensor's signal lines must also be fitted with safety transformers according to EN 61558.

2.3 Grounding and potential connection

All connecting wires (including the cable screening braid) are electrically insulated from the sensor body.

The insulation resistance between the connecting wires and the sensor body is measured.

The test certificate states that the minimum resistance is greater than 30 M Ω (test voltage 45 V).

2.4 Storage

- The sensor must be stored under the following conditions only:
 - dry
 - no condensation
 - temperature between 0 °C and 60 °C

Note:

Provided the storage conditions have been observed, no special steps need to be taken after storage and prior to commissioning.

3. Principle of operation

The sensor operates with the aid of a spring element. The force to be measured deforms the spring element elastically.

This deformation is transformed into an electrical signal by strain gauges. They, together with the spring element, constitute the measuring element of the sensor.

3.1 Spring element

The spring element is the most important mechanical part of a load cell. Its purpose is to take the force being measured and convert it into a linear extension. It relies on the elastic properties of the material in order to determine the force indirectly.

The materials of which load cells are made must satisfy other conditions in addition to their elastic properties. As a result, only a small number of carefully selected materials come into question for high-quality load cells.

burster is going one step further than this, using mainly materials from the aeronautical industry that satisfy additional quality requirements in the place of DIN materials.

3.2 Mechanical structure

In the model 8431, measuring from zero up to and including 500 N, and for all measuring ranges of the model 8432, the spring element is implemented as opposing bending beams.

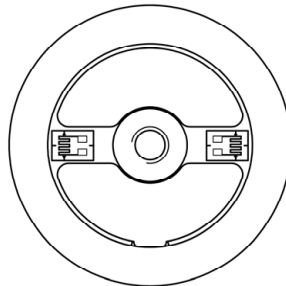

Figure 1: The spring element comprises opposing bending beams

The model 8431 measuring element for measurement ranges from 0 ... 1 kN up to 0 ... 5 kN consists of a spring element in the form of a horizontal membrane.

All other measuring elements used in this sensor are implemented as a compression body.

Strain gages measure the extension on the surface of the spring element.

Being fixed to the surface of the spring element, the application of force subjects the strain gage to the same deformation as the spring element. This permits the extension, and therefore the force, to be measured electrically.

3.3 Function of the strain gauge

The electrical resistance of a wire rises with increasing length and falling cross-section. When a wire is pulled, it becomes thinner and longer – both of these effects result in an increase in its electrical resistance.

This is the principle on which the function of strain gauges is based. In practice, however, strain gauges do not consist of a single wire, but of a metal foil laminated onto a carrier material. The metal foil is etched to create a meandering structure (see Figure 2:).

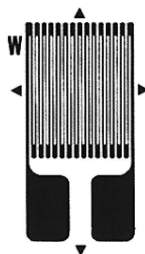

Figure 2: Foil strain gauge

Special techniques are used to mount strain gauges manufactured in this way onto the surface of the spring element.

3.4 Strain gauge wiring

In order to reduce undesirable influences on the measurement, the strain gauges in the force sensors on the model 8431 and the 8432 are connected as a Wheatstone bridge. Figure 3 illustrates this wiring in a simplified form.

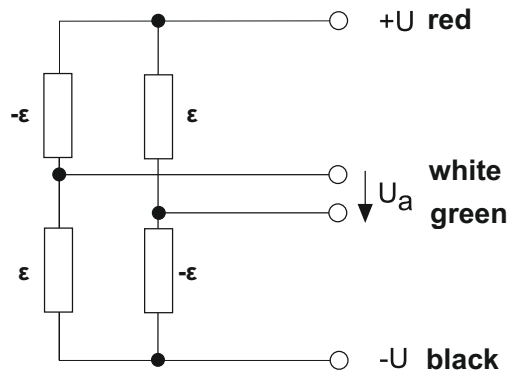

Figure 3: Full-bridge strain gage

In addition to the four strain gauges shown here, compensation resistors to reduce the effect of temperature and balancing resistors to balance the bridge circuit are also incorporated.

Depending on the sensor model, further resistors for the purpose of standardizing the rated characteristic are integrated into the cable or the connector.

The output voltage of the sensor at maximum load, U_a , is calculated as follows:

$$U_a = c \times U_b$$

- U_b : excitation voltage
- c : characteristic value (sensitivity) of the sensor.

The sensitivity parameter "c" can be found in the test report. Typically it is somewhere between 1.5 and 2.0 mV/V.

If excitation voltages (U_b) in the range of 2.5 to 5 V are used, 0...100 % loading of the sensor yields output voltages (U_a) between 4 and 10 mV.

3.5 Deflection full scale

The bending beam element, or the horizontal membrane, are deformed by the load, depending on the direction of the force. On those sensors with swaged elements, the load either pulls the measuring element or pushes it together. In either case, the height of the sensor changes under the influence of the load. This deformation, the measuring distance, is so small that it cannot be seen with the naked eye, being in the range between 20 and 40 μm .

3.6 External forces



Caution!

Sensor will be damaged!

Avoid vibrations, pulsed loads and rapidly varying forces, even if these are less than the rated maximum. Design your measuring system in such a way as to prevent these external forces.

External forces here refer to any force that acts outside the sensor's axis of symmetry - transverse forces, bending moments and twisting moments in particular. To reduce the sensitivity of sensors to such forces, thin supporting membranes are integrated into the housing. These keep the parts that introduce force to the sensor centered precisely on its central axis and offer high mechanical resistance to forces acting in their own plane. On the other hand, they transmit forces unimpeded that act perpendicular to their plane. As a result, a transverse load of rated magnitude acting perpendicularly to the active sensor axis at the level of the upper edge of the housing generates a measurement error of only 2 % of full scale (shear stress). With the same arrangement, but with a transverse load at a height of 50 mm above the upper edge of the housing, the resulting measuring error is a maximum of 3 % of full scale (bending stress).

These figures are for guidance only, they refer to static forces.

3.7 Overload protection

Note:

The sensor model 8432 is protected against overload in the directions of both tension and compression. There is no protection against bending torques, shearing forces or torsional torques acting during assembly or operation.

Note:

Movement of the sensor spring element is blocked when loaded between 120 % and 150 % of the rated maximum. Beyond this stage, the evaluation electronics will not show any further load increase.

The precision miniature load cell model 8432 includes an integrated mechanical overload protection for the tension and compression directions. This protection only operates in the sensor's direction of measurement.

Refer to data sheet for the maximum overloads of the several measurement ranges.

If, despite precautions, the sensor has been overloaded, you will notice this immediately by a change in the output signal for the zero point.

- Get the sensor checked out if you notice a change in the signal of 5 % or more (higher or lower) while no load is present.

4. Installation

4.1 Surrounding mechanical parts and fastening

4.1.1 Adaptation



Caution!

Excessive torque will damage the measuring element!

Maximum torque when tightening the threaded bolt: 0.7 Nm (finger-tight)

Model 8431 and 8432 sensors are fitted into the surrounding structure by means of the external threading. In each case, there is an "active" and a "passive" side. The passive side is always tightly joined to the sensor, forming one unit with it.

On the model 8431 sensors for measuring ranges from 0 ... 500 N, and for all sensors of model 8432, the threaded bolt can be unscrewed from the active side.

This threaded bolt is dismantled when the units are supplied to prevent the measuring element from being overloaded during transport.

- Screw in the threaded bolt all the way to the stop.

The maximum torque for assembly is 0.7 Nm.

Note:

Force should only be applied to the sensor through the outer threads. The internal thread of parts fitted to the machine may – but does not have to – contact the shoulder underneath the external thread.

Even parts that are fitted onto the sensor can create unacceptable external forces as a result of their own weight. The axes that transmit forces must therefore be held by bearings or guides. These bearings or guides must be located as near as possible to the sensor.

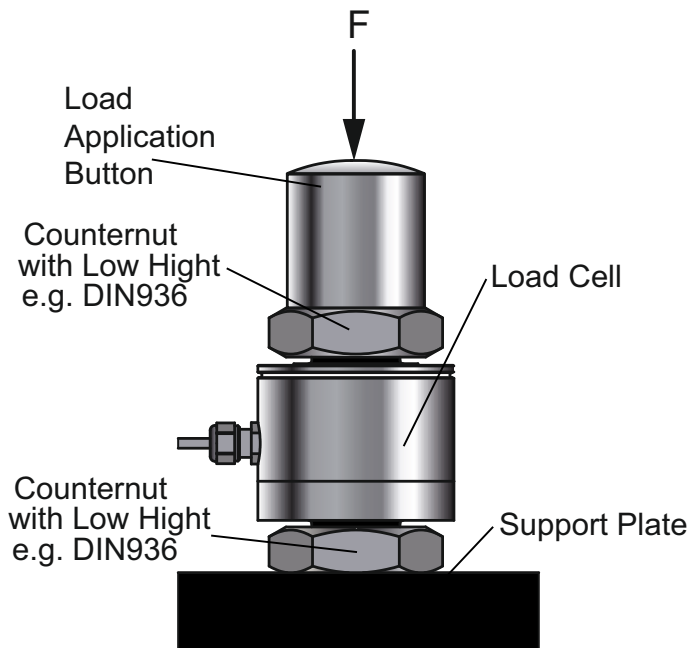

Figure 4: measuring setup in principle used for compressive force measurements

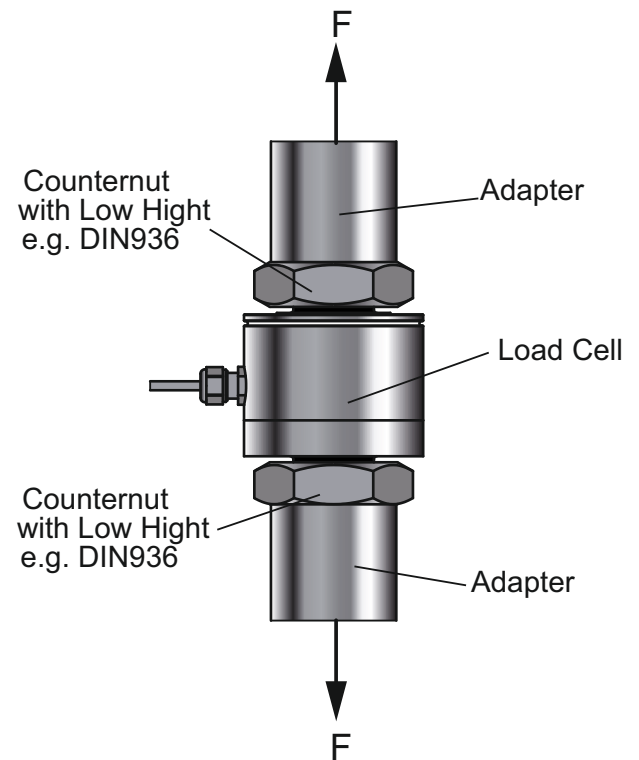

Figure 5: measuring setup in principle used for tensile force measurements

4.1.2 Mounting



Caution!

Damage to the measuring element!

Maximum torque when tightening the threaded bolt: 0.7 Nm (finger-tight)

The two internal threads that hold the sensor must be axially aligned. There must be no offset in either position or angle.

Fastening the sensor

You must connect the sensor to the evaluation electronics before you begin. Observe the display during assembly. This will help you to avoid overloading the measuring element.

- Manually screw the sensor into the internal thread provided.

Maximum torque for assembly 0.7 Nm.

If the cable outlet is to point in a particular direction:

- Align the sensor as desired.
- Fix the sensor in this position.

You can fix the sensor in its position using assembly adhesive or a counter-screw.

4.2 Electrical connections, evaluation devices

When supplied with 5 V, the output signal of the 8431 and 8432 sensors is typically in the range from 0 to 10 mV. Accurate measurement also requires a resolution of better than 5 μ V. The sensor, sensor cable and measuring instrument must therefore be shielded from interference.

The following points apply to the sensor's electrical connection:

- Locate the sensor and the measuring instrument outside the range of high-energy equipment.

This includes transformers, motors, contactors, frequency converters and so forth. Otherwise the electromagnetic fields from such equipment will act with their full effect on the measuring chain, causing incorrect measurements.

- Lay the measuring lines separately from high-power cables.

If the measuring lines are laid parallel to such cables, interference will be coupled in inductively and capacitively.

The following points apply to the shield's electrical connection:

- Refer to the information given in the test certificate.
- If the shield emanates from the cable, follow the user specific operation instructions.
- For burster equipment, the cable shield should usually be connected to the (protective) earth.
- For class II equipment, the cable shield should be connected to the sensor excitation (usually the functional earth FE). It is essential to take the ground connections of the output-side electronics into account.

In some cases it will be helpful to place an extra shield as additional protection over the measuring cable, or to lay it in a metal tube or pipe.

5. Measuring chain adjustment

The sensors of the model 8431 and model 8432 are calibrated ex works. Because of this, every sensor has an individual test and calibration report.

However, you basically have to align every following electronic to the particular sensor. After this adjustment you have done a basic adjustment of the measuring chain.

5.1 Adjustment using the data of the test and calibration report

Depending on the type of the following electronic, you are able to insert the data of test and calibration report directly or you have to use strain gauge simulator or a shunt resistor. With the help of this strain gauge simulator or a shunt resistor you are able to pretend the electric values to the electronic.

5.2 Adjustment using calibration offset (shunt calibration)

Function

During shunt adjustment, a precision resistor (the calibration shunt) is connected between the negative pin of the signal input and the negative pin of the reference supply voltage. The imbalance thus created in the bridge circuit corresponds to a specific change in length, i.e. to a particular load applied to the load cell. An offset, defined in this way, appears at the same time in the output signal, and can be used to adjust the entire measurement chain. The magnitude of the change in the output signal, and the value of the associated calibration shunt, can be found in the sensor's test certificate.

5.3 Adjustment with a physical magnitude

Function

The sensor is subjected to a known physical magnitude. In this way, the calibration is carried out over the entire measuring chain, consisting of the sensor and display device or amplifier.

Adjustment

- Remove any load from the sensor.
- Adjust the zero.
- Load the sensor with a known reference weight.
- Adjust the reference scale value.

If desired, we can prepare factory calibration or recalibration certificates for the sensor or for the entire measuring chain.

These measurements are carried out at the factory on measurement installations.

5.4 Adjustment using a strain gauge simulator

Function

A strain gauge simulator is a bridge simulation circuit, built from precision resistors, which can be put into various output states. The strain gauge simulator (e.g. the burster strain gauge simulator model 9405) is connected to the instrumentation amplifier instead of the sensor.

5.5 Adjustment using a precision voltage source

Note:

The supply voltage of full-bridge strain gauge sensors affects the result of the measurement. It is possible that the actual supply voltage will vary slightly from the rated supply voltage. If you want to verify the proper function of the instrumentation amplifier using a voltage source, you must measure the sensor supply voltage with a precision digital voltmeter, and then calculate the calibration voltage.

Function

The sensor is simulated by a precision voltage source (e.g. the burster DIGISTANT[®] model 4411 or 4423), which you connect to the instrumentation amplifier.

6. Note

Exclusion of warranty liability for operating manuals

All information in the present documentation was prepared and compiled with great care and reproduced subject to effective control measures. No warranty is provided for freedom from errors. We reserve the right to make technical changes. The present information as well as the corresponding technical data can change without notice. Reproduction of any part of this documentation or its processing or revision using electronic systems is prohibited without the manufacturer's prior written approval.

Components, devices and measured value sensors made by burster praezisionsmesstechnik (hereinafter referred to as "product") are the results of targeted development and meticulous research. As of the date of delivery, burster provides a warranty for the proper condition and functioning of these products covering material and production defects for the period specified in the warranty document accompanying the product. However, burster excludes guarantee or warranty obligations as well as any liability beyond that for consequential damages caused by improper use of the product, in particular the implied warranty of success in the market as well as the suitability of the product for a particular purpose. Furthermore, burster assumes no liability for direct, indirect or incidental damages as well as consequential or other damages arising from the provision and use of the present documentation.

Technical Product Information
Commissioning, Function, Fitting Specifications
Models 8431, 8432

Technical inquiries:
(+49) 07224 / 645 - 0



1057-BA8431EN-5070-021515