

OPERATION MANUAL

Digital indicator Model 9163

©2011 burster
präzisionsmesstechnik gmbh & co kg
All rights reserved

Manufacturer:
burster praezisionsmesstechnik gmbh & co kg
Talstrasse 1 – 5 P.O. Box 1432
76593 Gernsbach, 76587 Gernsbach,
Germany Germany

Valid from: 26.07.11

Tel.: (+49) 07224 / 6450
Fax.: (+49) 07224 / 64588
E-Mail: info@burster.de
www.burster.de

Note:

Exclusion of warranty liability for operating manuals

All information in the present documentation was prepared and compiled with great care and reproduced subject to effective control measures. No warranty is provided for freedom from errors. We reserve the right to make technical changes. The present information as well as the corresponding technical data can change without notice. Reproduction of any part of this documentation or its processing or revision using electronic systems is prohibited without the manufacturer's prior written approval.

Components, devices and measured value sensors made by burster praezisionsmesstechnik (hereinafter referred to as "product") are the results of targeted development and meticulous research. As of the date of delivery, burster provides a warranty for the proper condition and functioning of these products covering material and production defects for the period specified in the warranty document accompanying the product. However, burster excludes guarantee or warranty obligations as well as any liability beyond that for consequential damages caused by improper use of the product, in particular the implied warranty of success in the market as well as the suitability of the product for a particular purpose. Furthermore, burster assumes no liability for direct, indirect or incidental damages as well as consequential or other damages arising from the provision and use of the present documentation.

Präzisionsmessgeräte, Sensoren und Messsysteme
für elektrische, thermische und mechanische Größen



EG-Konformitätserklärung

EC-Declaration of Conformity according to EN ISO/IEC 17050-1:2004

Name des Herstellers: burster präzisionsmesstechnik gmbh & co kg
Manufacturer's Name:

Adresse des Herstellers: Talstr. 1-5
Manufacturer's Address: 76593 Gernsbach, Germany

erklärt unter alleiniger Verantwortung, dass das gelieferte Produkt
declares under sole responsibility that the product as originally delivered

Produktname: Sensormaster
Product Name: Digital Indicator

Modellnummer(n) (Typ): 9163
Models Number / Type:

Produktoptionen: Diese Erklärung beinhaltet obengenannte Produkte mit allen Optionen
Options This declaration covers all options of the above product(s)

mit den folgenden europäischen Richtlinien übereinstimmt und entsprechend das CE-Zeichen trägt:
complies with the requirements of the following applicable European Directives, and carries the CE marking accordingly:

2006/95/EC <i>Low Voltage</i>	Elektrische Betriebsmittel zur Verwendung innerhalb bestimmter Spannungsgrenzen <i>Electrical Equipment designed for use within certain voltage limits</i>
2004/108/EC <i>EMC</i>	Elektromagnetische Verträglichkeit <i>Electromagnetic Compatibility</i>

Obengenannte Produkte entsprechen folgenden harmonisierten Normen:
Above named products conform with the following product standards:

Sicherheit:	IEC 61010-1:2001 / EN 61010-1:2001	Messkategorie 1	Schutzklasse II Einbau Version Schutzklasse I Tisch Version <i>safety class 1 Panel Version</i> <i>safety class 2 Desktop Version</i>
<i>Safety requirements:</i>		CAT 1	

EMV Störaussendung: IEC/CISPR 11:2003 + A1:2004 + A2:2006 / EN 55011:2007 + A2:2007
EMC Generic emission:

EMV Störfestigkeit: IEC 61326-1:2005 / EN 61326-1:2006
EMC Generic immunity: Industrie Bereich
Industrial environment

Ergänzende Informationen: Um optimale Störfestigkeit zu erreichen ist das Produkt über geschirmte Leitungen anzuschließen.
Additional Information: In order to reach optimal electromagnetic immunity the device has to be conducted with shielded line
Das Produkt wurde in einer typischen Konfiguration getestet.
The product was tested in a typical configuration.

Diese Konformitätserklärung betrifft alle nach Ausstellungsdatum ausgelieferten Produkte:
This DoC applies to above-listed products placed on the EU market after:

Gernsbach 09.07.2008 i.V. Alfred Großmann
Datum / date *Quality Manager*

Dieses Dokument ist entsprechend EN ISO/IEC 17050-1:2004 Abs. 6.1g ohne Unterschrift gültig / *According EN ISO/IEC 17050 this document is valid without a signature.*

burster präzisionsmesstechnik gmbh & co kg · Talstr. 1-5 · D-76593 Gernsbach (Postfach 1432 D-76587 Gernsbach) Tel. 07224/645-0 · Fax 645-88
www.burster.de · www.burster.com · info@burster.de

Sitz der Gesellschaft: HFA 530170 Mannheim · Komplementär: burster präzisionsmesstechnik Verwaltungs-GmbH · Sitz der Gesellschaft: Gernsbach HRB 530130 Mannheim
Geschäftsführer: Matthias Burster · Prokurist: Edgar Miggl · UST-Identnr.: DE 144 005 098 · Steuernr.: 39454/10503
Dresdner Bank AG Rastatt Kto. 06 307 073 00 BLZ 662 800 53 · Volksbank Baden-Baden* Rastatt eG Kto. 302 082 00 BLZ 662 900 00



9163 as panel-mount unit



9163 as bench-top unit



Contents

1.	For your safety	11
1.1	Warnings and notes.....	11
1.2	General warnings	12
2.	Introduction	13
2.1	Normal use	13
2.2	Customer Service	14
2.2.1	Customer service department.....	14
2.2.2	Factory warranty	14
2.2.3	Address.....	14
2.2.4	Equipment data.....	15
2.3	Basic model	15
2.4	Options	15
2.4.1	Panel-mount unit.....	15
2.4.2	Bench-top unit.....	15
2.4.3	DigiVision 9163-P100 software	16
3.	Preparing for use.....	17
3.1	Unpacking.....	17
3.2	Installation / panel-mounting.....	18
3.2.1	Installation dimensions.....	18
3.2.2	Installation instructions.....	18
4.	Electrical connections	21
4.1	Panel-mount unit	22
4.1.1	Inputs and outputs on the 9163 Vxxxx0 version (single-channel unit)	22
4.1.2	Inputs and outputs on the 9163 Vxxxx1 version (two-channel unit)	27
4.1.3	Inputs and outputs on both versions	35
4.1.4	Power supply	40
4.2	Bench-top unit	42
4.2.1	Connector pin assignments.....	43
4.2.2	Connections	46

5. Controls	55
6. Power-up	57
6.1 Self-diagnosis	57
6.2 Measurement mode	57
6.3 Errors during measurement mode	58
7. Basic operation	59
7.1 Accessing a specific menu	59
7.2 Accessing the parameters in the menu	59
7.3 Adjusting a parameter value	60
7.4 Returning to the main menu	60
7.5 Operating hierarchy	61
7.5.1 Level 1	61
7.5.2 Main menu	62
8. Retrieving information on the current status	63
8.1 Displaying the software version	63
8.2 Displaying the equipment code	63
8.3 Displaying the error code for a specific input	64
8.4 Displaying the position of the decimal point	65
8.5 Displaying the scale values	66
9. Input configuration	69
9.1 Configuring a main input	69
9.2 Configuring an auxiliary input	75
9.3 Selecting the sensor excitation	79
9.4 Selecting the transmitter excitation voltage 15 V / 24 V	80
10. Output configuration	81
10.1 Specifying the output parameters	81
10.2 Selecting the analog output	82
10.3 Fine adjustment of the analog output	85
10.4 Setting alarm limits	86
10.4.1 Enabling alarm limits	88
10.4.2 Configuring an alarm limit	88
10.4.3 Adjusting an alarm limit	96
10.4.4 Selecting the contact type (NC / NO)	97

11. Interface configuration	98
11.1 Configuring the serial interface	98
11.2 Profibus interface (only for instruments with the Profibus option)	99
12. Hardware configuration	101
12.1 Accessing the protected area	101
12.2 Parameter lock	102
12.3 Instrument settings	105
12.3.1 Mathematical functions	105
12.3.2 Button assignment	111
12.3.3 Digital inputs	113
12.3.4 Display settings	115
13. Sensor-specific calibration	118
13.1 Potentiometer or linear signals	118
13.2 Strain Gauge Sensors and Strain Gauge Simulators	121
13.3 RTD (PT100)	129
13.4 Thermocouple (TC).....	131
13.5 Input linearization	132
13.6 Restoring factory-set calibration	136
14. Instrument power-up / power-down via software (stand-by).....	139
14.1 Switch-off (power-down / stand-by)	139
14.2 Switch-on (power-up).....	139
15. Maintenance.....	141
15.1 Cleaning	141
15.2 Repair	141
15.3 Troubleshooting.....	142
16. Technical specifications.....	143
17. Order codes, accessories and options	145
18. Appendix.....	147
18.1 Menu options	147
18.2 Block diagram	158
18.3 Functional block diagram.....	159



1. For your safety

1.1 Warnings and notes



The symbol on the instrument denotes that the user should refer to the operating instructions



DANGER!

in this manual warns of immediate hazards which result in severe personal injury or death.



WARNING!

in this manual refers to a hazard or unsafe practice which can result in severe personal injury or death.



CAUTION!

in this manual refers to a hazard or unsafe practice which can result in personal injury or product or property damage.

Note:

This indicates precautions which should be observed to ensure proper handling of the equipment

1.2 General warnings



WARNING!

The following instructions must be followed to prevent electric shock and injuries:

- Observe all safety notices and instructions.
- Do not connect voltages that are higher than those specified. The voltage ranges supported are listed in the technical specifications.
- Disconnect the digital indicator from the power supply before opening it.
- Make sure that all the parameter sets are correct before operating the instrument.
- Do not use the instrument if it is damaged.
- Never use the instrument in explosive areas.



CAUTION!

The following points must be observed to prevent injuries and damage to property:

- The 230 V unit has Class II protection and is classified as Installation Category II.
- Instruments with 20...27 V AC/DC power supply must only be supplied from a current source with Class III protection.
- Connect a two-pole circuit breaker (with CE mark) in the input supply to the instrument to disconnect the power supply. The circuit breaker must be installed in the immediate vicinity of the instrument within easy reach of the user. One circuit breaker can be used for more than one instrument.
- External control circuits connected to the instrument must have Class II insulation.
- The circuit boards in the instrument are sensitive to electrostatic voltage. Take suitable precautions when handling the boards.
- Never use hydrocarbon-based cleaning solvents (e.g. benzene etc.)

2. Introduction

This instrument is designed to measure rapidly changing electrical quantities. It includes up to two analog main inputs plus two auxiliary inputs, which can be used for numerous potential applications such as differential measurements.

The main inputs are suitable for standard linear signals and for pressure transducers, load cells, potentiometers, thermocouples and resistance thermometers. Custom linearization of the inputs is also possible.

The inputs can be configured via the keypad.

This range of indicators from burster provides the ideal solution for all applications in which high performance and continuous operation is vital.

Such applications include:

- Pressure sensing and monitoring (absolute or difference value)
- Position sensing and monitoring
- Monitoring limits of measured values in automatic systems involving high-speed processes, with a signal feedback option

The instrument has two digital inputs in addition to the analog inputs. These can be used for functions such as reset and hold.

In addition, up to four relay or logic outputs with configurable function are available.

An optional (opto-isolated) high-resolution analog output can also be provided for functions such as analog signal feedback of actual values, peak values, limits and difference values.

The 9163 digital indicator can optionally be fitted with a Profibus-DP interface. This provides a simple means of interfacing the 9163 digital indicator to an automation system.

2.1 Normal use

The 9163 digital indicator is designed to measure rapidly changing electrical quantities. It can be used in numerous potential applications including differential measurements.

The inputs of the 9163 are configured via the keypad. They are suitable for standard linear signals and for pressure transducers, load cells, potentiometers, thermocouples and resistance thermometers. Custom linearization of the inputs is also possible.

2.2 Customer Service

2.2.1 Customer service department

For enquiries about repairs

Please call us on:

07224-645-53

Please have your serial number ready for such enquiries. We need this number to find out the technical specifications of your instrument and hence provide you with rapid assistance.

The serial number is shown on the type plate.

2.2.2 Factory warranty

burster praezisionsmesstechnik gmbh & co kg provides a manufacturer's warranty for a period of 24 months after delivery.

Any repairs required during this time will be made without charge.

Damage caused by improper use of the device is not covered by the warranty.

If you are returning the device for repairs, please note the following requirements for packing and shipping:

- If you have a problem with the unit, please attach a note to the case summarizing the fault.
- Technical specifications subject to change at any time without notice. We also state explicitly that we do not accept liability for consequential damage.

2.2.3 Address

burster praezisionsmesstechnik gmbH & co kg
Talstrasse 1 – 5
D-76593 Gernsbach, Germany
Tel: 0049 (0)7224 – 645 – 0
Fax: 0049 (0)7224 – 645 – 88
e-mail: info@burster.de

2.2.4 Equipment data

- Please enter the information from the type plate in the table below after unpacking the instrument.

If you need to contact the burster Customer Service department, you will need to quote this information.

SN:	_____	(serial number)
CODE:	_____	(finished product code)
Type:	_____	(order code)
Supply:	_____	(type of power supply)
VERS:	_____	(software version)

2.3 Basic model

- 1 main input for strain gauge sensors, potentiometers, DC/DC sensor, PT100 or thermocouples.
- 2 auxiliary inputs for standard signals and potentiometers
- 1 power supply for transmitters
- 2 configurable data inputs, p switching (PNP)
- 1 selectable sensor excitation, suitable for strain gauge sensors, potentiometers or transmitters
- 4 outputs: relay outputs OUT1, OUT2, OUT3 and OUT4

2.4 Options

2.4.1 Panel-mount unit

- One additional main input (useful for differential measurements)
- Analog output
- Opto-isolated serial interface, RS232, RS485
- Profibus connection

2.4.2 Bench-top unit

- One additional main input (useful for differential measurements)
- Analog output
- Opto-isolated serial interface, RS232, RS485
- USB connection

2.4.3 DigiVision 9163-P100 software

The 9163 digital indicator is part of an equipment family supported by the PC-based DigiVision data acquisition software. The digital indicator must have the RS232 / RS485 option to be able to use this software tool.

By purchasing this additional software package, you can visualize up to eight measurements at once. In addition, DigiVision lets you display a range of process and test data.

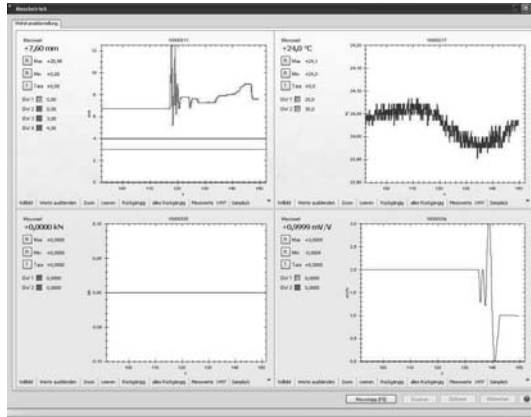

DigiVision also gives you access to various settings and options for the 9163.

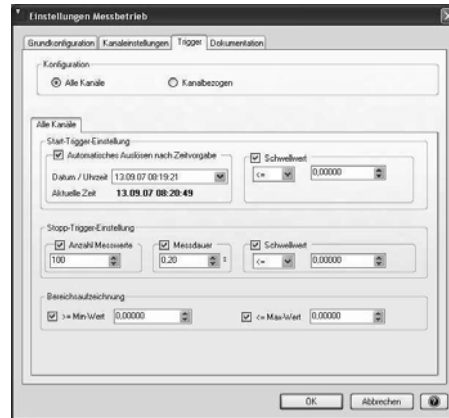
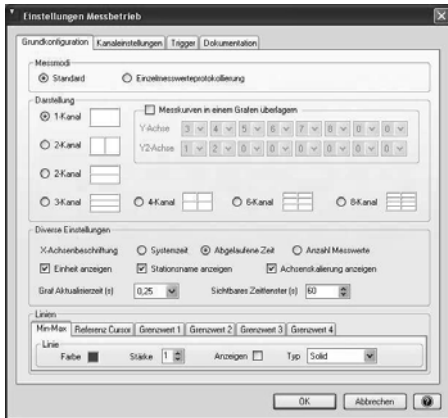

In addition, DigiVision includes a facility for exporting measurements to an Excel file.

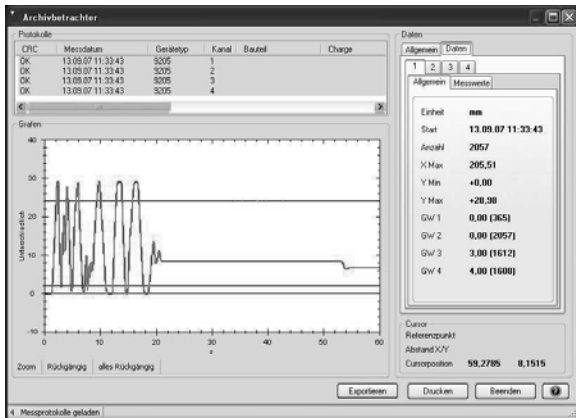

burster Excel-Messwerte		
Original Messprotokoll dates	C:\dokumente und einstellungen\All Users\Documents\burster\DigiVision	
Fortlaufende Dateinummer	11	
Beginn	13.09.2007 11:33:43	
Firma	burster	
Prüfer	User	
Gerätebezeichnung	10000334	
Geräte-SN	10000334	
Einheit	mV/V	
Anzahl Messwerte	2057	
Messwertreihe	Zeit	Messwert
1	0,002830	2,001
2	0,052580	2,000
3	0,151940	2,000
4	0,251430	2,000
5	0,352050	2,000
6	0,451520	2,000
7	0,552150	2,000
8	0,652120	2,000
9	0,751610	2,000
10	0,852460	2,000
11	0,952080	2,000
12	1,052320	2,000
13	1,151940	2,000
14	1,251790	2,000
15	1,351650	2,000
16	1,451790	2,000

3. Preparing for use

3.1 Unpacking

Perform these tasks immediately after unpacking:

- Enter the technical data from the type plate in the table in section 2.2.4: "Equipment data".

If you need to contact the burster Customer Service department, you will need to quote this information.

- Inspect the instrument carefully for damage.
- Check that the shipment is complete.

A standard package includes:

- 9163 digital indicator
 - 2 fixing clips
 - Shock protection
 - Dust protection seal
 - Operating manual
- Make sure that the order code matches the device configuration.

The digital indicator must be configured correctly for the given application.

- Correct number and type of inputs/outputs
 - Required options and accessories present
 - Correct supply voltage
- Please notify burster immediately of any discrepancies, missing parts or signs of damage.
 - Before installing the 9163 series unit in the instrument panel, read section 3.2: "Installation / panel-mounting".

3.2 Installation / panel-mounting

3.2.1 Installation dimensions

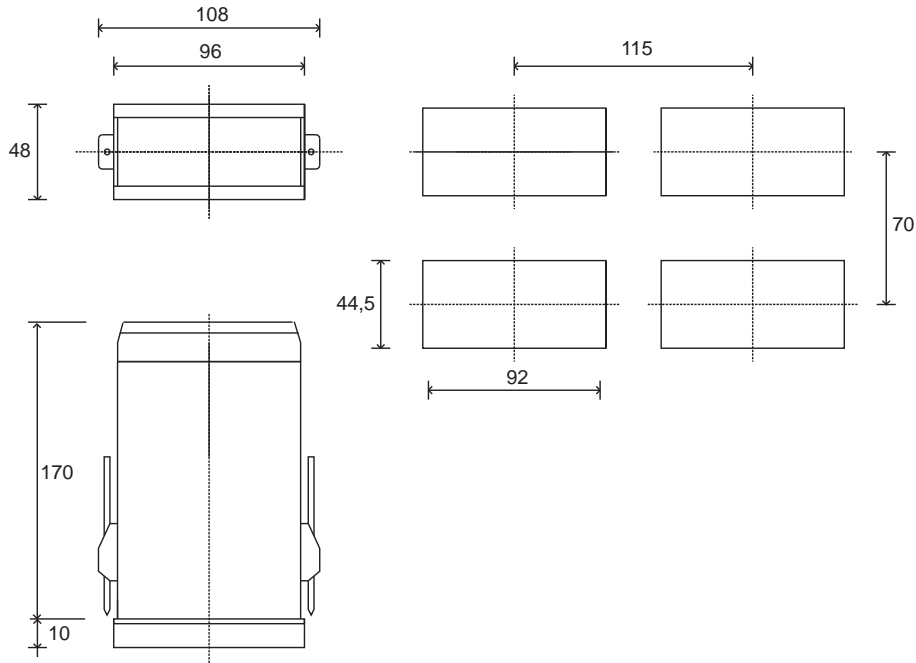

Figure 1: Installation dimensions of the 9163 digital indicator (dimensions in millimeter)

3.2.2 Installation instructions

- Read the basic installation rules before you install the unit.

If you do not follow our safety instructions, there may be problems with electrical safety and electromagnetic compatibility.

Furthermore, disregarding the safety instructions will forfeit the warranty.

Basic installation rules for the 9163

If you connect the unit to devices that are **not** electrically isolated (e.g. thermocouples):

- Provide a dedicated conductor for the ground connection.

The ground connection must never be made directly via the machine rack.

If you install the unit in applications in which there is a risk of personal injury, damage to machinery or property:

- Combine the unit with additional limit monitoring equipment.
- Check regularly during operation whether the alarm limit has actuated.

If sensors are operating in an inflammable or explosive atmosphere:

- Connect these sensors to the unit solely via suitable isolating points.
All interfaces must comply with the applicable regulations.
- Lay the mains-voltage cables separately from the input and output lines to the unit.
- Arrange the sensor leads separately from the power section and relays.
- Never install the units in control rooms in which contactors, relays, thyristor controllers (in particular those using phase control), motors, high-power remote switches etc. are installed.
- Never expose the unit to dust, moisture, corrosive gases or heat sources.
- Ensure that the ventilation slots are unobstructed.
The ventilation slots must never be covered.
The operating temperature must lie in the range 0 °C to 50 °C.
The maximum ambient temperature is 50 °C
- Use cable lugs designed for a tightening torque of 0.5 Nm.



CAUTION!

Risk of electric shock!

The 230 V unit has Class II protection and is classified as Installation Category II

Instruments with 20...27 V AC/DC power supply must only be supplied from a current source with Class III protection.

The panel-mount unit does not have an On/Off switch!

Connect a two-pole circuit breaker (with CE mark) in the input supply to the instrument to disconnect the power supply.

The circuit breaker must be installed in the immediate vicinity of the instrument within easy reach of the user.

One circuit breaker can be used for more than one instrument.

The digital indicator pack contains the following installation components:

- Fixing clips (A) for fitting the unit in the instrument panel
 - Seal (B) for protecting against dust and water spray
- Fit the digital indicator in the instrument panel as shown in the diagram.



Figure 2: Fitting the digital indicator

4. Electrical connections



CAUTION!

Risk of electric shock!

The 230 V unit has Class II protection and is classified as Installation Category II

Instruments with 20...27V AC/DC power supply must only be supplied from a current source with Class III protection.

The panel-mount unit does not have an On/Off switch!

Connect a two-pole circuit breaker (with CE mark) in the input supply to the instrument to disconnect the power supply. The circuit breaker must be installed in the immediate vicinity of the instrument within easy reach of the user.

One circuit breaker can be used for more than one instrument.

All connecting terminals are on the rear of the unit.

Section 16: "Technical specifications" contains the technical specifications.

Table 1: Cables for electrical connections to digital indicator

Function	Cable type	Length
Connecting lead	up to 1 mm ²	1 m
Connecting leads to relay output	up to 1 mm ²	3.5 m
Serial connection cable	up to 0.35 mm ²	3.5 m
Thermocouple input	up to 0.8 mm ² compensated	5 m
Input for strain gauge sensors, potentiometers, linear signals from PT100 resistance thermometers	up to 1 mm ²	3 m
Analog outputs for signal feedback	up to 1 mm ²	3.5 m
Digital inputs / outputs	up to 1 mm ²	3.5 m

4.1 Panel-mount unit

4.1.1 Inputs and outputs on the 9163 Vxxxx0 version (single-channel unit)



CAUTION!
Risk of electric shock!
External control circuits connected to the instrument must have Class II insulation.

Note:

All capacitors must be of VDE standard class (class x2) and capable of withstanding a voltage of at least 230 V AC. The maximum power dissipation capacity of the resistor must equal at least 2 W.

Note:

The company of burster präzisionsmesstechnik gmbh & co kg does not accept liability under any circumstances for personal injury or property damage resulting from unauthorized access, improper use or inappropriate operation or use given the technical properties of the unit, or from use that contravenes the instructions given in the present operating manual.

Follow these instructions when connecting the unit:

- Arrange the input leads separately from the leads for the power supply, and from the outputs and main power lines.
- Use twisted/screened cable with its shield grounded at least at one end.
- For output lines that are switched under load (cotactor, solenoid valves, motors, fans etc.), connect an RC element (resistor and capacitor in series) in parallel with the load.

This will suppress interference emissions.

- For an inductive load, connect a type 1N4007 diode in parallel with the load.

Electrical connections 9163-Vxxxx0

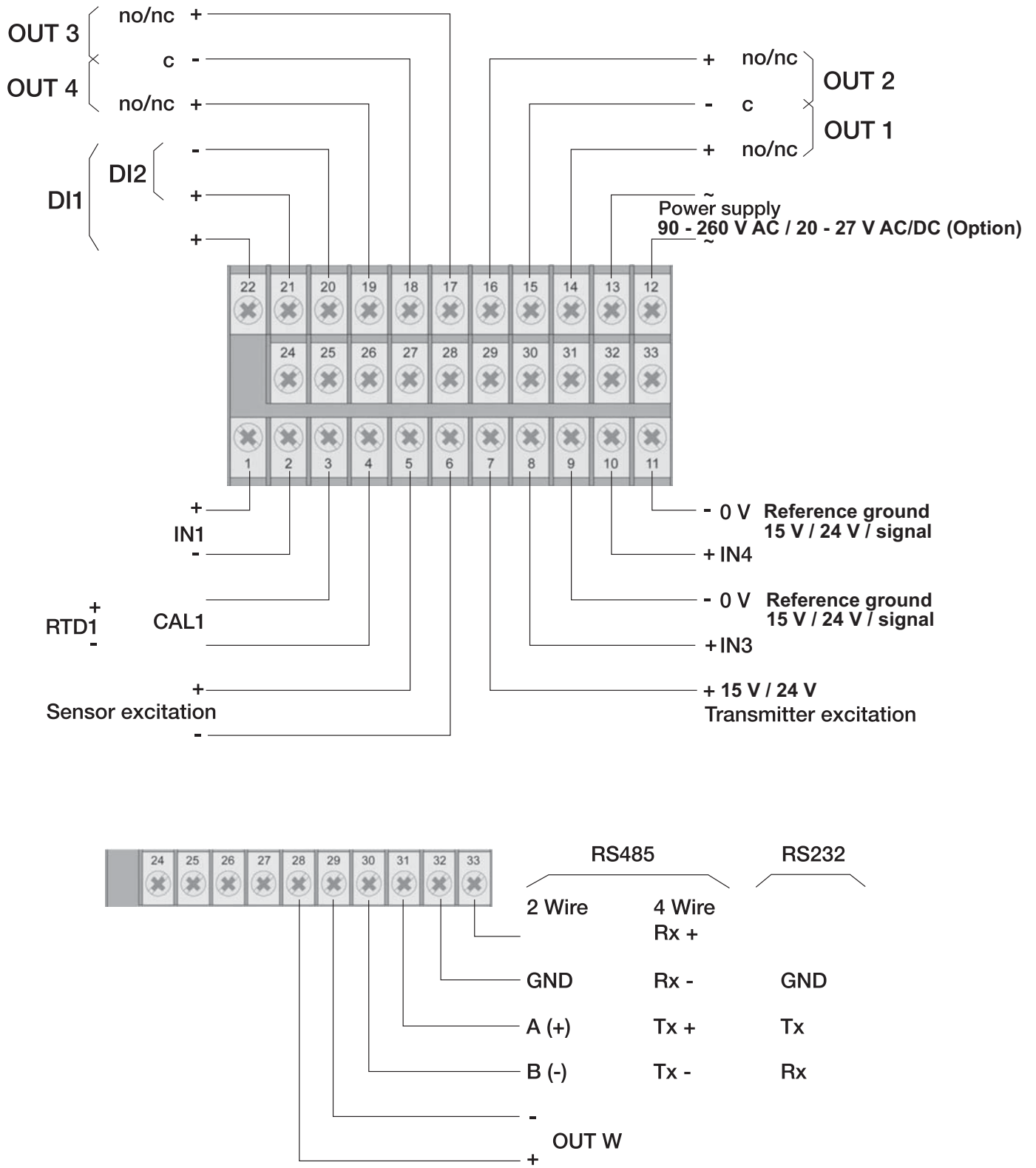
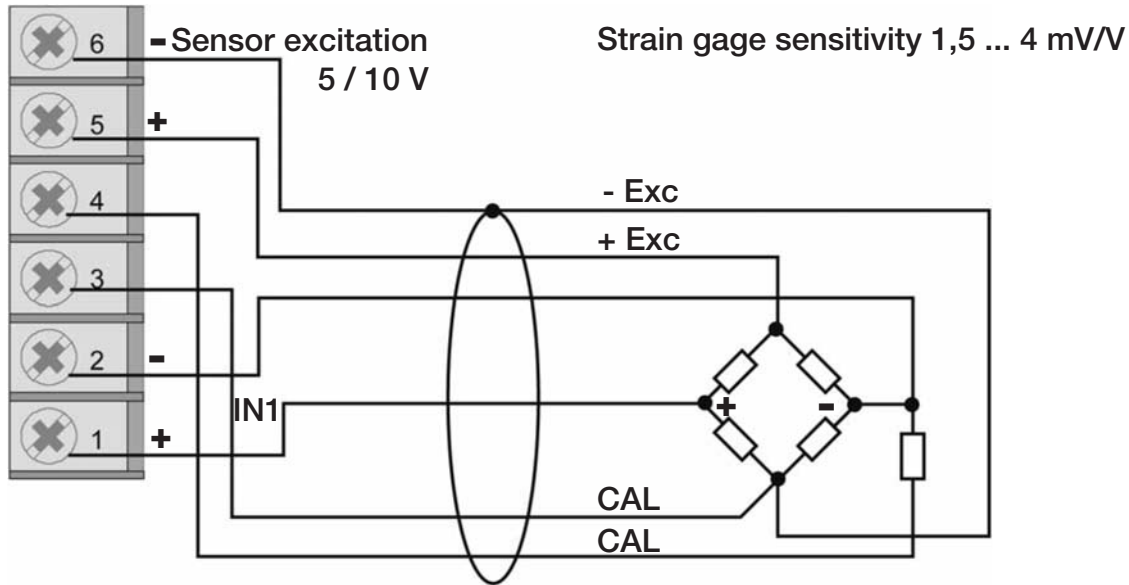

Figure 3: Electrical connections to the digital indicator, 9163 Vxxxx0 version, in summary

Input IN1 strain gauge sensor, 4-wire



Note:

The test and calibration report for the sensor will specify the size of the calibration resistor.

Input IN1 TC – thermocouple

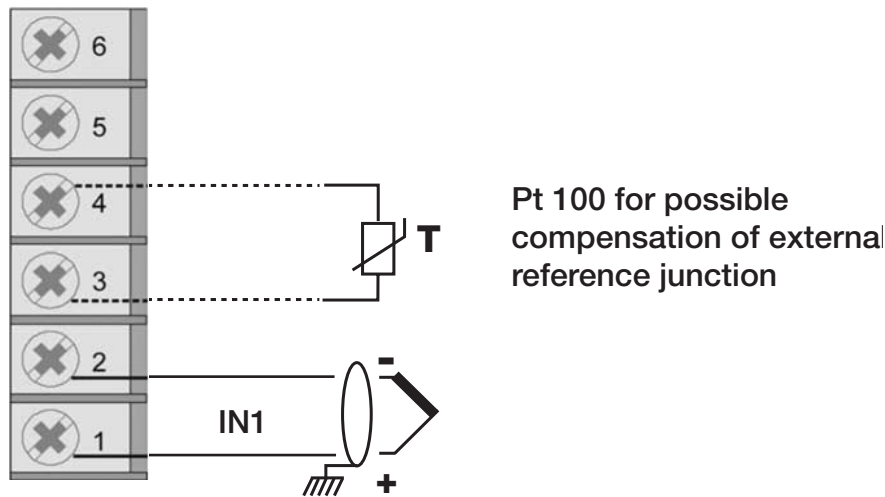

You can connect thermocouples of type J, K, R, S and T.

Following customized linearization, you can also connect thermocouples of type B, E, N, L, U, G, D and C.

- Make sure you connect the polarity correctly.
- Use a suitable compensation line for extending the lead.

Input IN1 connected to 3-wire transmitter with excitation supplied by unit

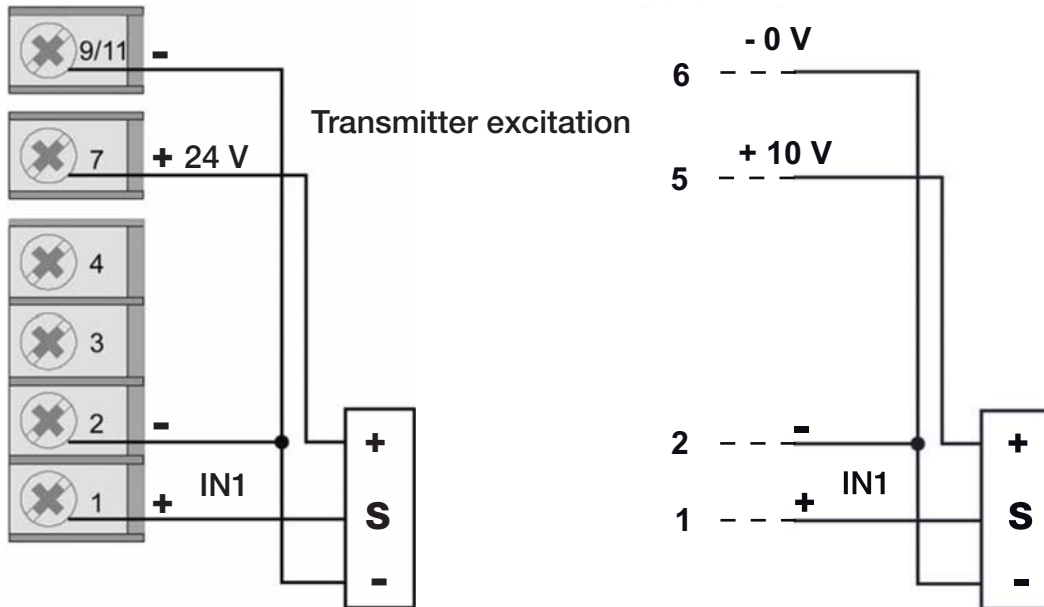

The sensor type depends on the selected transmitter.

Input IN1 connected to 2-wire transmitter with excitation supplied by unit

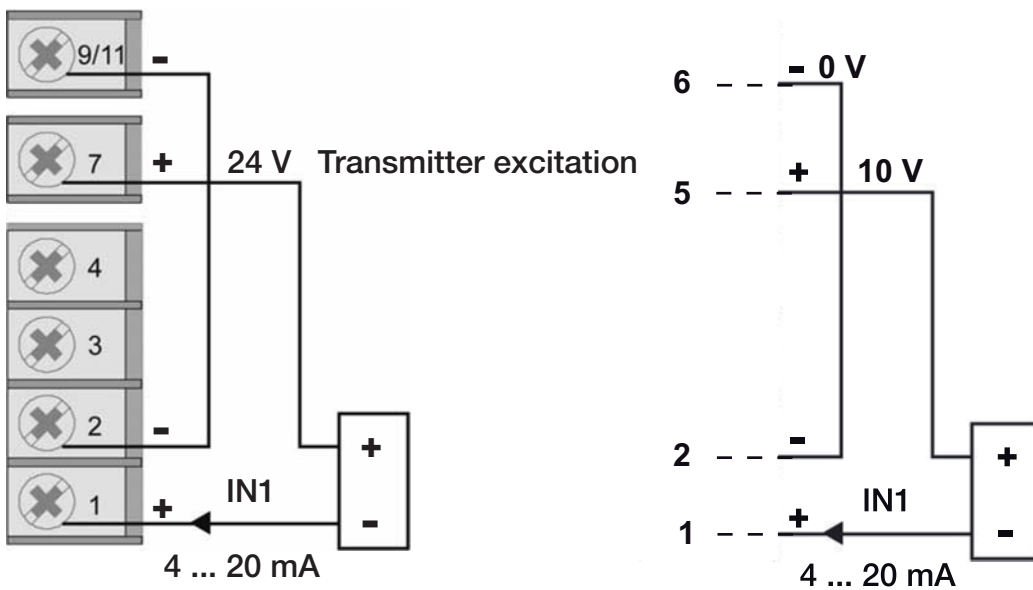

Input IN1 (current)

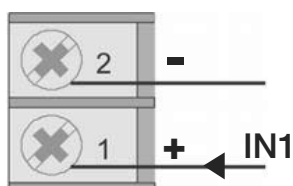

This input is suitable for a linear DC current signal

Current level	Output impedance
0/4 mA to 20 mA	50 Ω

Input IN1 (voltage)

This input is suitable for a linear DC voltage signal

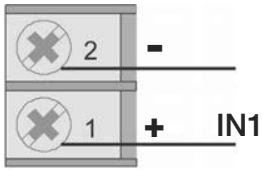

Voltage	Output impedance
±60 mV	>10 MΩ
±100 mV	>10 MΩ
±1.0 V	>2 MΩ
±5.0 V	>2 MΩ
±10.0 V	>2 MΩ

Input IN1 potentiometer

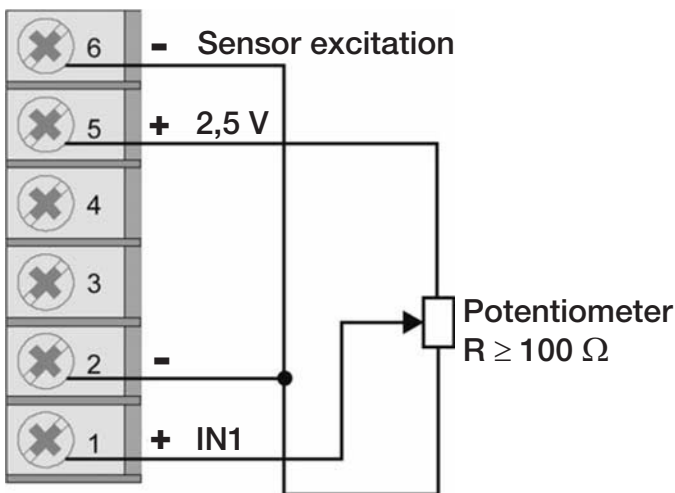

Input IN1 PT100

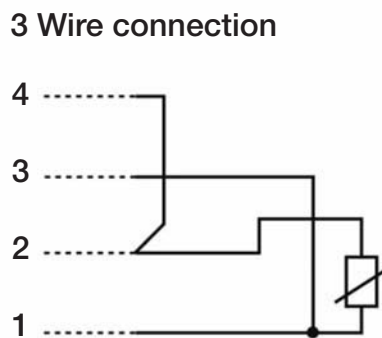
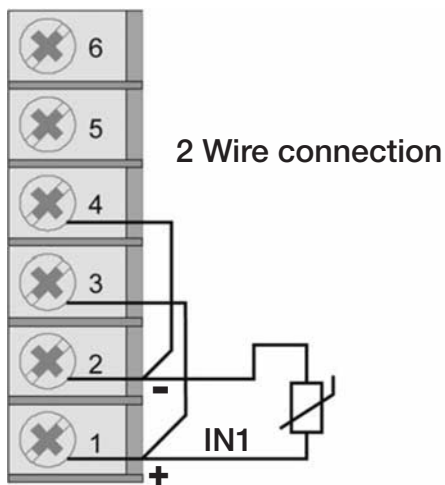

Note:

Only use connecting leads with a suitable cross-section i.e. > 1 mm².

4.1.2 Inputs and outputs on the 9163 Vxxxx1 version (two-channel unit)



CAUTION!

Risk of electric shock!

External control circuits connected to the instrument must have Class II insulation.

Note:

All capacitors must be of VDE standard class (class x2) and capable of withstanding a voltage of at least 230 V AC. The maximum power dissipation capacity of the resistor must equal at least 2 W.

Note:

The company of burster präzisionsmesstechnik gmbH & co kg does not accept liability under any circumstances for personal injury or property damage resulting from unauthorized access, improper use or inappropriate operation or use given the technical properties of the unit, or from use that contravenes the instructions given in the present operating manual.

Follow these instructions when connecting the unit:

- Arrange the input leads separately from the leads for the power supply, and from the outputs and main power lines.
- Use twisted/screened cable with its shield grounded at least at one end.
- For output lines that are switched under load (contactor, solenoid valves, motors, fans etc.), connect an RC element (resistor and capacitor in series) in parallel with the load.

This will suppress interference emissions.

- For an inductive load, connect a type 1N4007 diode in parallel with the load.

Electrical connection 9163-Vxxxx1

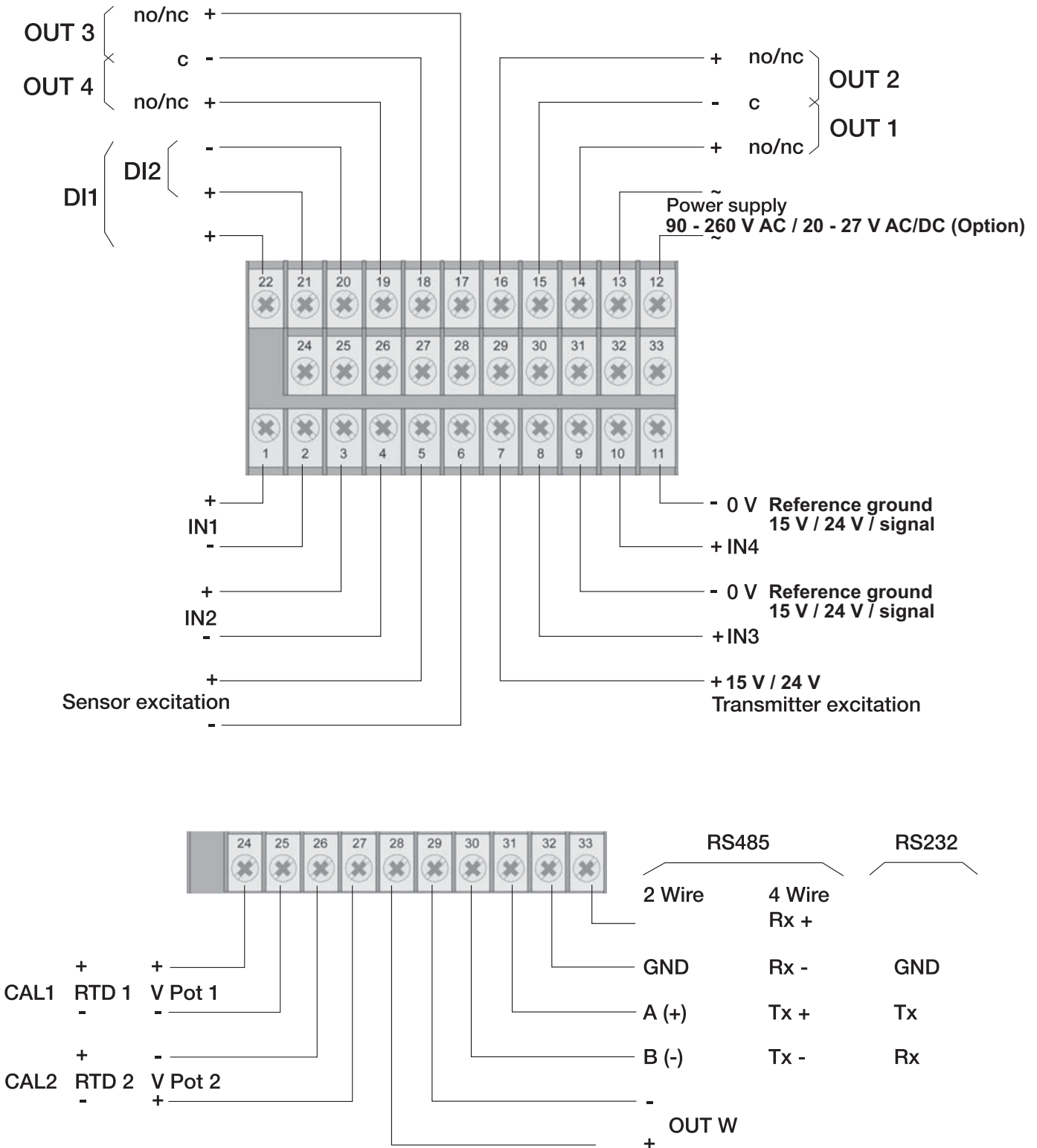
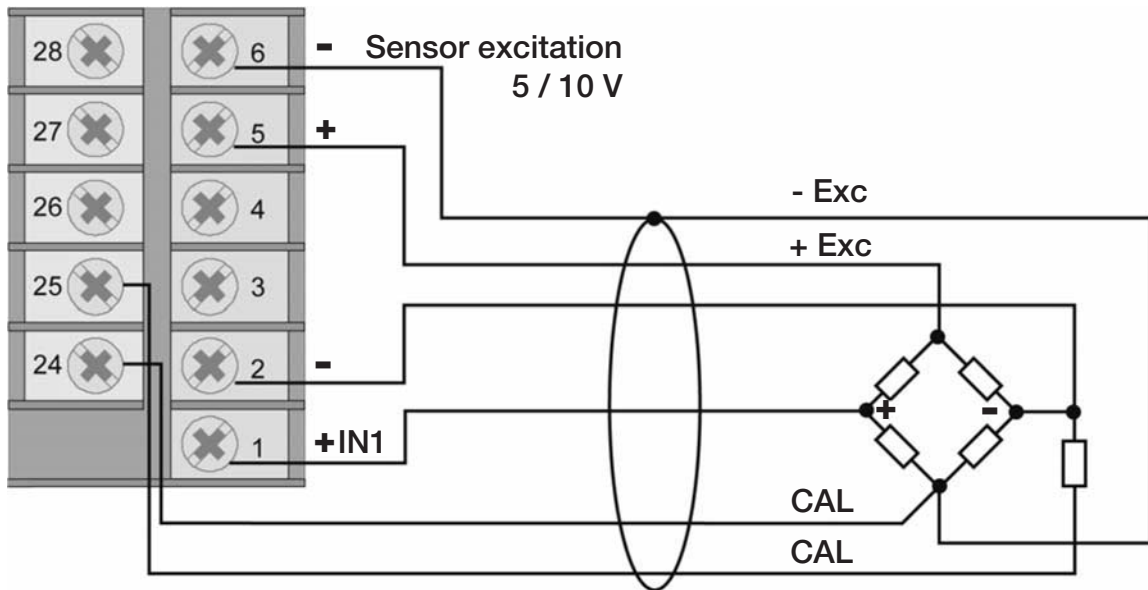

Figure 4: Electrical connections to the digital indicator, 9163 Vxxxx1 version, in summary

Input IN1 strain gauge sensor, 4-wire



Note:

Connect the "CAL" sensor line to terminal 24 so that it is at the same potential as "-Exc". If the connecting leads are swapped over, the digital indicator displays the error "H i" or "E.CAL.x" after an 80 % calibration.

The test and calibration report for the sensor will specify the size of the calibration resistor.

Input IN2 strain gauge sensor, 4-wire

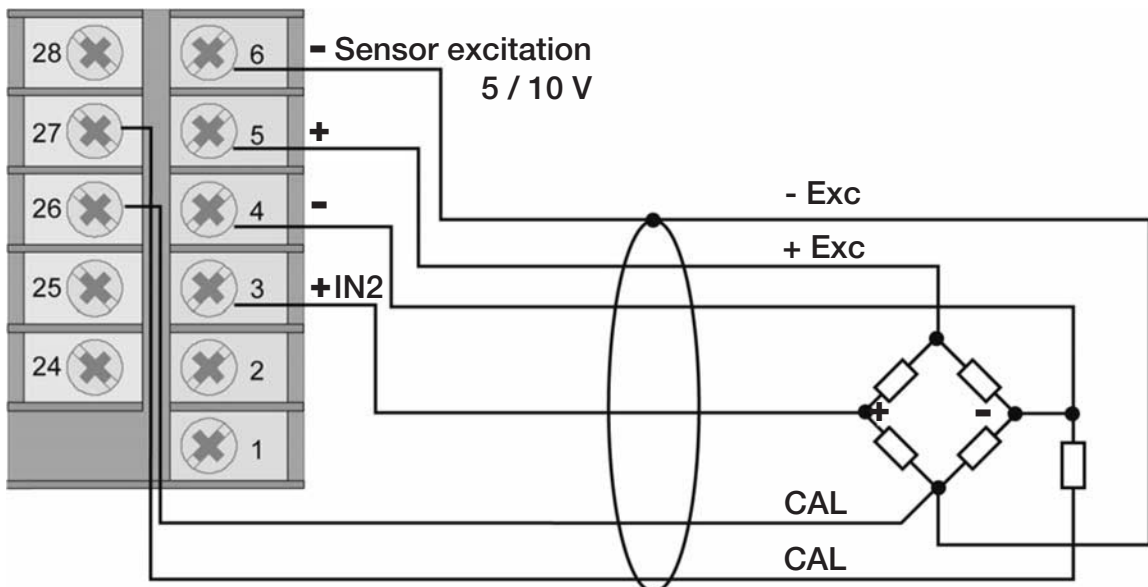

Note:

Connect the "CAL" sensor line to terminal 26 so that it is at the same potential as "-Exc". If the connecting leads are swapped over, the digital indicator displays the error "H i" or "E.CAL.x" after an 80 % calibration.

The test and calibration report for the sensor will specify the size of the calibration resistor.

Input IN1 TC – thermocouple

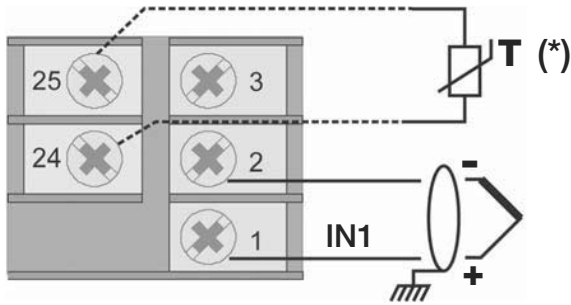

* Pt100 for compensation of external reference junction if required

Input IN2 TC – thermocouple

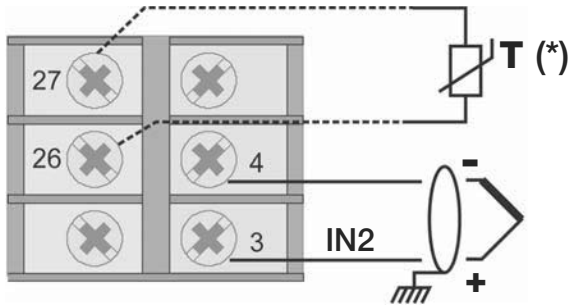

* Pt100 for compensation of external reference junction if required

You can connect thermocouples of type J, K, R, S and T.

Following customized linearization, you can also connect thermocouples of type B, E, N, L, U, G, D and C.

- Make sure you connect the polarity correctly.
- Use a suitable compensation line for extending the lead.

Input IN1 connected to 3-wire transmitter with excitation supplied by unit

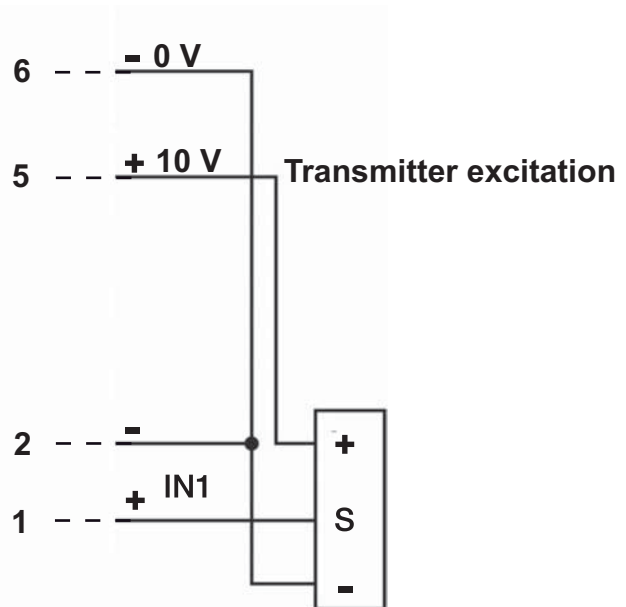
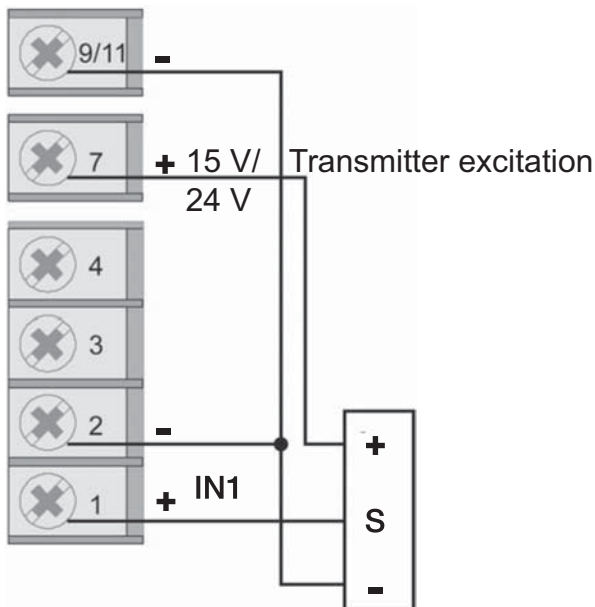

Input IN2 connected to 3-wire transmitter with excitation supplied by unit

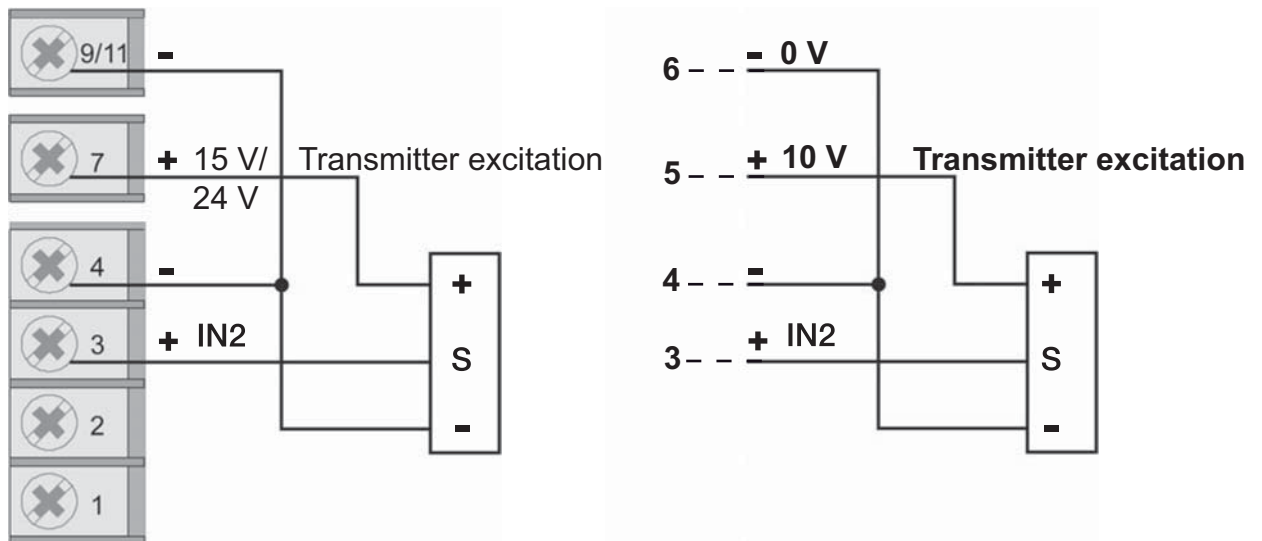

The sensor type depends on the selected transmitter.

Input IN1 connected to 2-wire transmitter with excitation supplied by unit

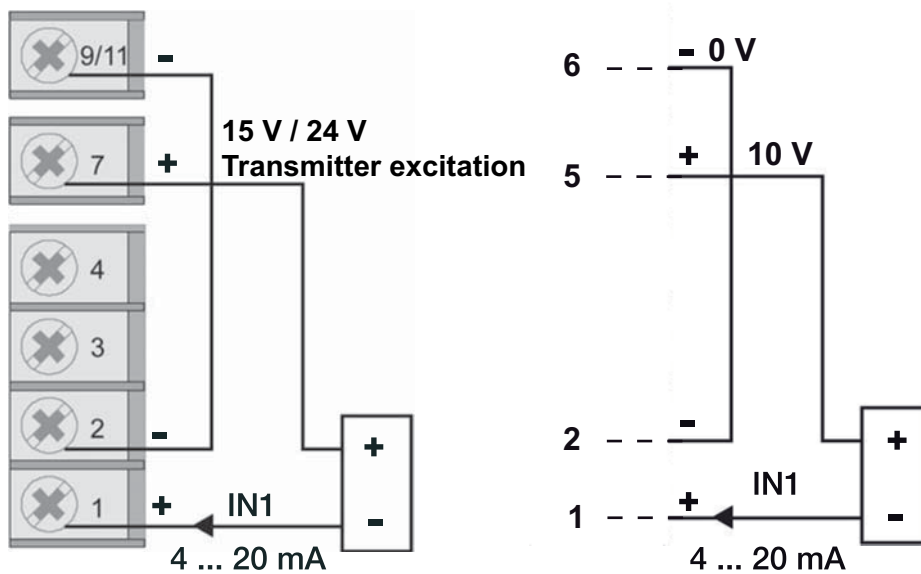

Input IN2 connected to 2-wire transmitter with excitation supplied by unit

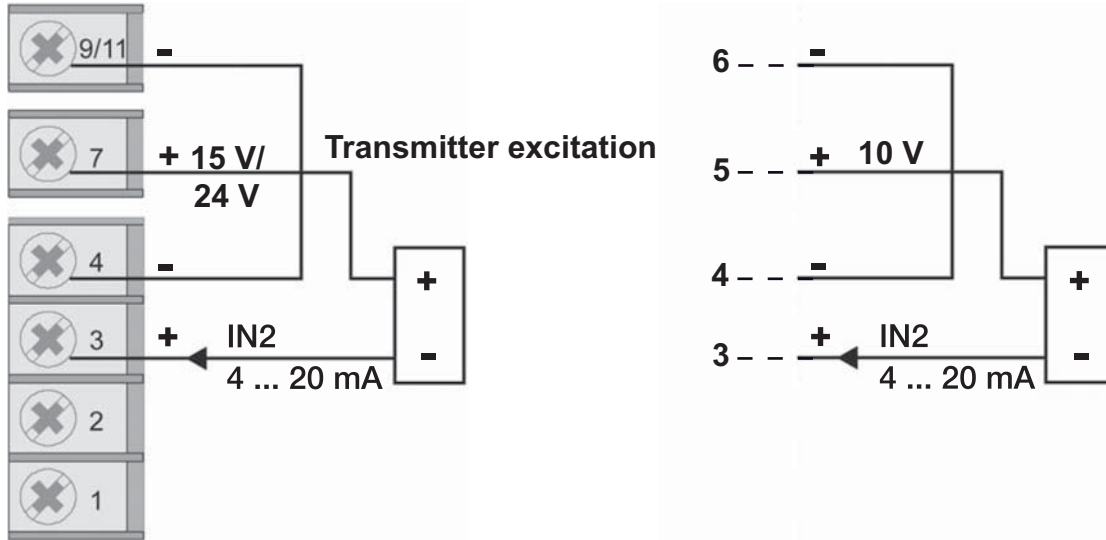

Input IN1 (current)

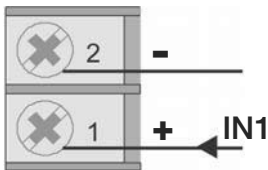

This input is suitable for a linear DC current signal

Current level	Output impedance
0/4 mA to 20 mA	50 Ω

Input IN1 (voltage)

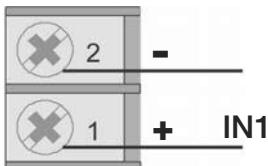

This input is suitable for a linear DC voltage signal

Voltage	Output impedance
±0.06 V	>10 MΩ
±0.1 V	>10 MΩ
±1.0 V	>2 MΩ
±5.0 V	>2 MΩ
±10.0 V	>2 MΩ

Input IN2 (current)

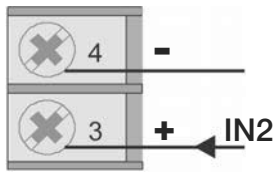

This input is suitable for a linear DC current signal

Current level	Output impedance
0/4 mA to 20 mA	50 Ω

Input IN2 (voltage)

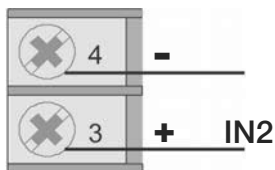

This input is suitable for a linear DC voltage signal

Voltage	Output impedance
±60 mV	>10 MΩ
±100 mV	>10 MΩ
±1.0 V	>2 MΩ
±5.0 V	>2 MΩ
±10.0 V	>2 MΩ

Input IN1 potentiometer

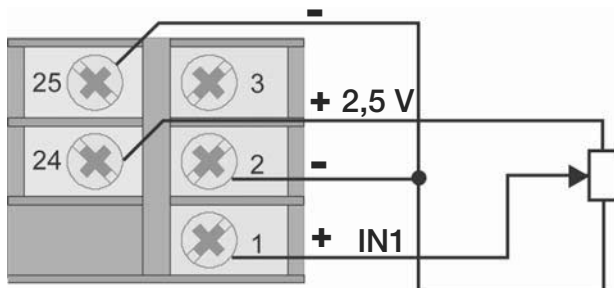

Potentiometer $R \geq 100 \Omega$
Spannungsversorgung 2,5 V

Input IN2 potentiometer

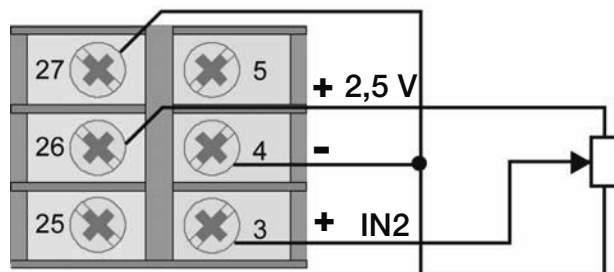

Potentiometer $R \geq 100 \Omega$
Spannungsversorgung 2,5 V

Input IN1 PT100

2-wire connection

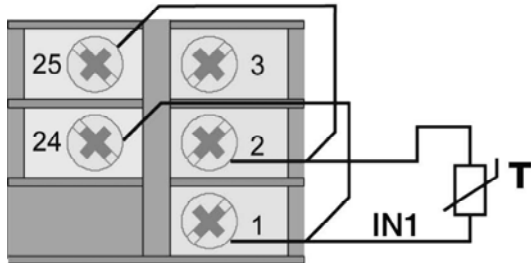

3-wire connection

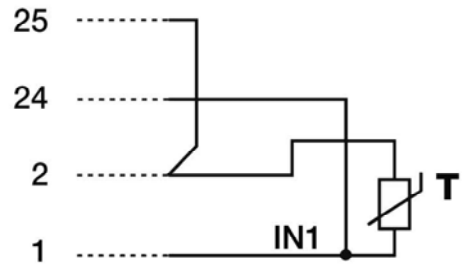

Note:

Only use wires with a suitable cross-section i.e. $> 1 \text{ mm}^2$.

Input IN2 PT100

2-wire connection

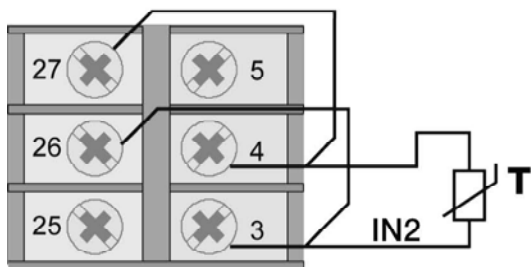

3-wire connection

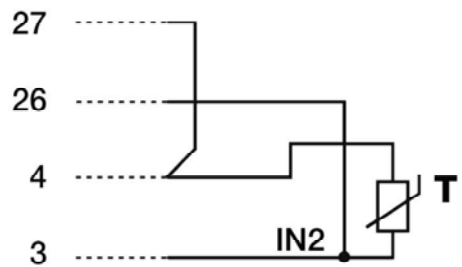

Note:

Only use wires with a suitable cross-section i.e. $> 1 \text{ mm}^2$.

4.1.3 Inputs and outputs on both versions



CAUTION!

Risk of electric shock.

External control circuits connected to the instrument must have Class II insulation.

Note:

All capacitors must be of VDE standard class (class x2) and capable of withstanding a voltage of at least 230 V AC. The maximum power dissipation capacity of the resistor must equal at least 2 W.

Note:

The company of burster präzisionsmesstechnik gmbH & co kg does not accept liability under any circumstances for personal injury or property damage resulting from unauthorized access, improper use or inappropriate operation or use given the technical properties of the unit, or from use that contravenes the instructions given in the present operating manual.

Follow these instructions when connecting the unit:

- Arrange the input leads separately from the leads for the power supply, and from the outputs and main power lines.
- Use twisted/screened cable with its shield grounded at least at one end.
- For output lines that are switched under load (contactor, solenoid valves, motors, fans etc.), connect an RC element (resistor and capacitor in series) in parallel with the load.

This will suppress interference emissions.

- For an inductive load, connect a type 1N4007 diode in parallel with the load.

Inputs IN3, IN4 connected to 3-wire transmitter with excitation supplied by unit

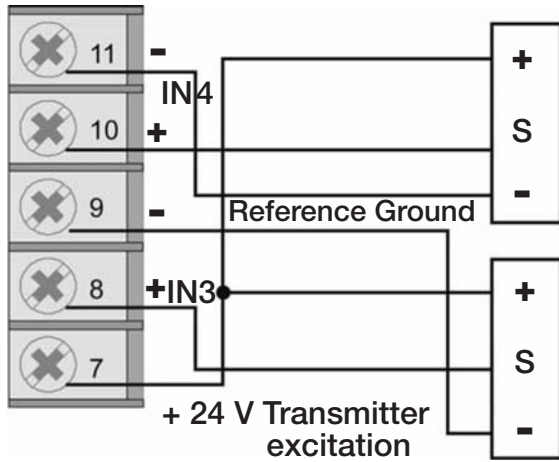

Inputs IN3, IN4 connected to 2-wire transmitter with excitation supplied by unit

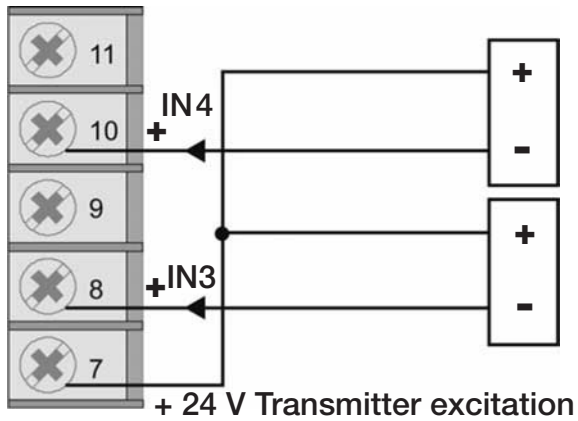

Inputs IN3 and IN4 (current)

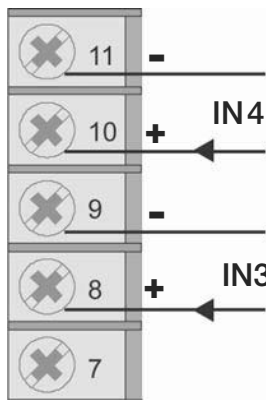

Inputs IN3 and IN4 (voltage)

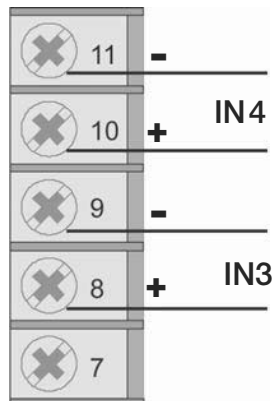

Inputs IN3 and IN4 potentiometer

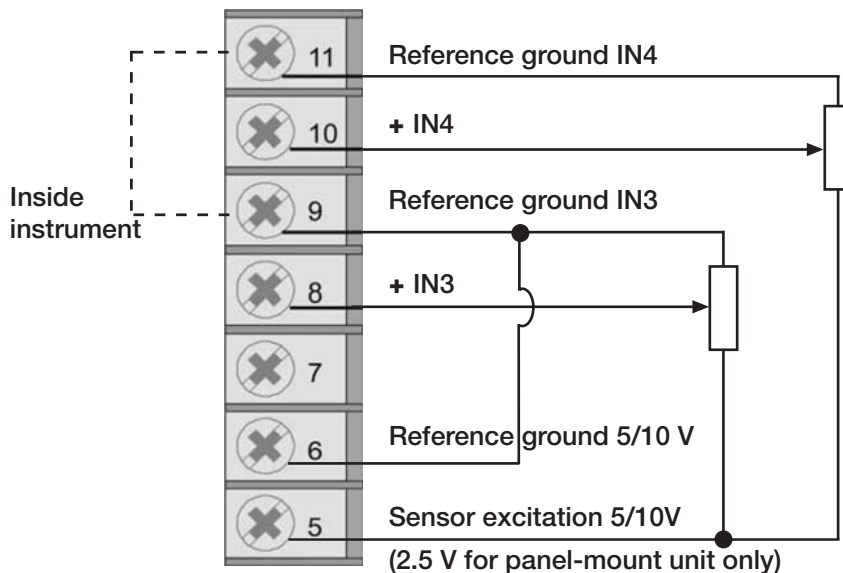

Vpot stands for the supply voltage to the potentiometer.

Digital inputs DI1 and DI2

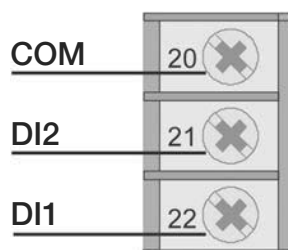

Digital inputs (PNP): 24V, maximum 5 mA (factory default).

Isolated contact (NPN): maximum 5 mA (Hd1).

Use the parameters $d\ 5.x$, in menu $H-d$ to enable the digital inputs DI1 and DI2.

You can find further information in section 12.3.3: "Digital inputs" on page 113.

Outputs OUT1, OUT2, OUT3 and OUT4 (Relay)

Relay: 5 A, 250 V AC / 30 V DC

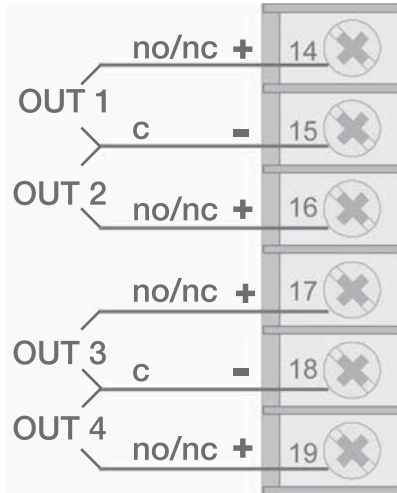

Digital outputs

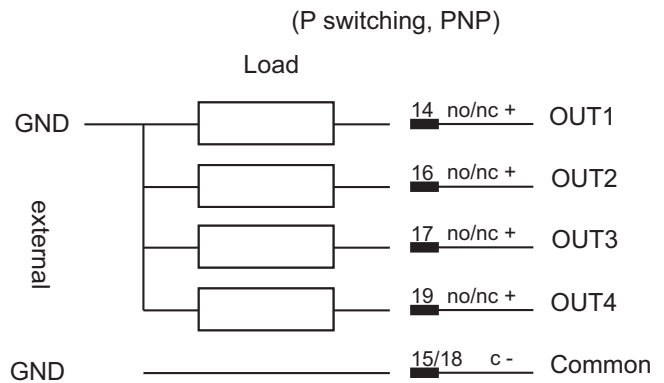
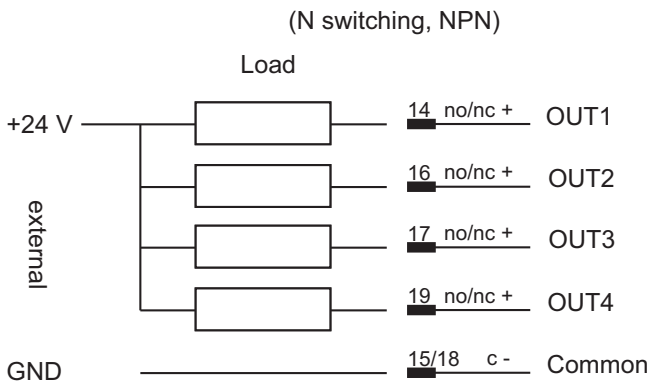

Connection to the analog output

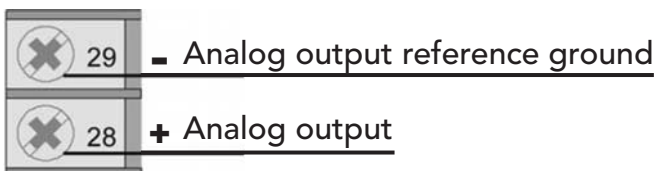

You can select the following output types:

02 ... 10 V, ± 10 V, max. 25 mA short-circuit protected

04 ... 20 mA for a maximum load of 500 Ω

Use configuration parameters to select the type.

Serial interface: RS232

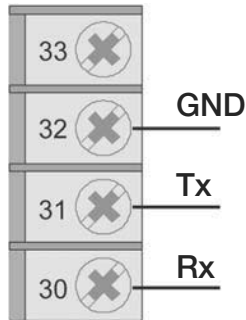

Serial interface: RS485 2-wire (standard)

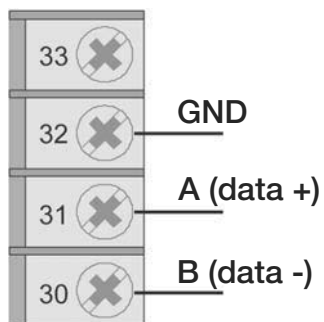

WARNING!

You will get an electric shock if the voltage is connected.

Disconnect the digital indicator from the power supply before opening it.

120 Ω termination resistor can be connected by:

closing jumper S3, opening S2.

Line polarization can be selected by:

closing jumper S4 (S6,S7,S9 closed; S8 open)

Serial interface: RS485 4-wire

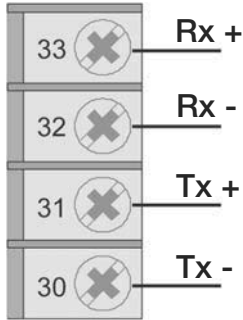



WARNING!

You will get an electric shock if the voltage is connected.
Disconnect the digital indicator from the power supply before opening it.

120 Ω termination resistor can be connected by:

closing jumper S3 (Tx), closing S2 (Rx).

Line polarization via Rx can be selected by:

closing jumpers S4, S5 (S6,S7,S9 open; S8 closed)

4.1.4 Power supply

Before connecting the 9163 to the power supply:

- Make sure that the instrument is suitable for the given supply voltage.

The appropriate supply voltage can be found from the order code for the unit:

Order code	Correct supply voltage
9163-V0xxxx	100 to 240 V AC/DC
9163-V1xxxx	20 to 27 V AC/DC

- Provide a circuit breaker with fuse for the power supply to the electronic instruments in the instrument panels.
- Always use cables with the correct voltage and current rating for the electrical connections.

You can find further information on suitable cables in section 4: "Electrical connections" on page 21.

The current and voltage values are listed in section 16: "Technical specifications" on page 143.

Using screw terminals for 9163 connection:

- Secure the cables at least in pairs.
- Connect the 9163 separately from electromechanical power switchgear.
The 9163 and electromechanical power switchgear such as relays, contactors, solenoid valves etc. must always be supplied from separate lines.
- Ground the equipment.

The following grounding conditions must be met:

- voltage between neutral line and ground <1V
- resistance <6 Ω.
- Use suitable line filters in the vicinity of high frequency generators or arc welding machines.
- Lay the mains-voltage cables separately from the signal lines.

If the power supply lead to the electronic instrumentation is subject to strong interference from switching of thyristor controllers or motors:

- Provide the 9163 with a dedicated isolating transformer with grounded shielding.

If the mains voltage is subject to strong fluctuations:

- Install a voltage stabilizer.



Figure 5: Power supply for the digital indicator

Standard :	100 to 240 V AC/DC ±10%
Optional:	20 to 27 V AC ±10%
Power:	max. 20 VA; 50/60 Hz

4.2 Bench-top unit



CAUTION!

Risk of electric shock!

External control circuits connected to the instrument must have Class II insulation.

Note:

All capacitors must be of VDE standard class (class x2) and capable of withstanding a voltage of at least 230 V AC. The maximum power dissipation capacity of the resistor must equal at least 2 W.

Note:

The company of burster präzisionsmesstechnik gmbh & co kg does not accept liability under any circumstances for personal injury or property damage resulting from unauthorized access, improper use or inappropriate operation or use given the technical properties of the unit, or from use that contravenes the instructions given in the present operating manual.

Follow these instructions when connecting the unit:

- Arrange the input leads separately from the leads for the power supply, and from the outputs and main power lines.
- Use twisted/screened cable with its shield grounded at least at one end.
- For output lines that are switched under load (contactor, solenoid valves, motors, fans etc.), connect an RC element (resistor and capacitor in series) in parallel with the load.

This will suppress interference emissions.

- For an inductive load, connect a type 1N4007 diode in parallel with the load.

4.2.1 Connector pin assignments

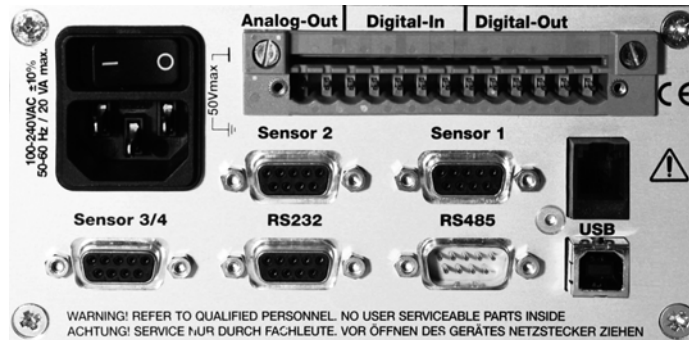
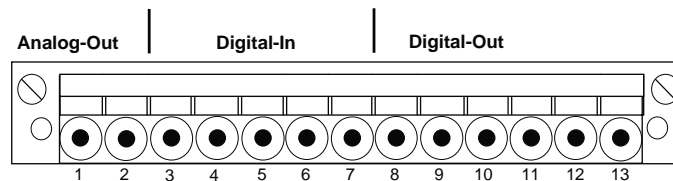

Figure 6: View towards the rear of the unit

Analog Out / Digital In / Digital Out



View towards the rear of the unit

Pin	Assignment	Pin	Assignment
1	+ analog output	8	+ OUT1
2	- reference ground, analog output	9	+ OUT2
3	+ digital input 1	10	+ OUT3
4	+ digital input 2	11	+ OUT4
5	- reference ground, digital inputs	12	not used
6	not used	13	- reference ground
7	not used		

Sensor 1 (IN1) and Sensor 2 (IN2)

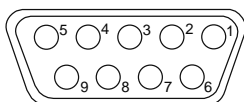

View towards the rear of the unit

Pin	Assignment	Pin	Assignment
1	+ sensor excitation 5 / 10 V	5	reference ground 5 / 10 V
2	+ CAL / + RTD	6	+ signal
3	+ transmitter excitation 15 / 24 V	8	ref. ground 15 / 24 V / signal
4	- CAL / - RTD	9	- signal

Sensor 3 / 4 (IN3 / IN4)

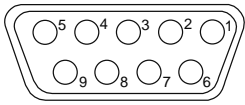

View towards the rear of the unit

Pin	Assignment	Pin	Assignment
1	+ sensor excitation 5 / 10 V	6	+ IN3 signal
3	+ transmitter excitation 15 / 24 V	8	ref. ground 15 / 24 V / signal
5	reference ground 5 / 10 V	9	+ IN4 signal

Adapter cable for burster standard connection to auxiliary channels (Sensor 3 / 4)

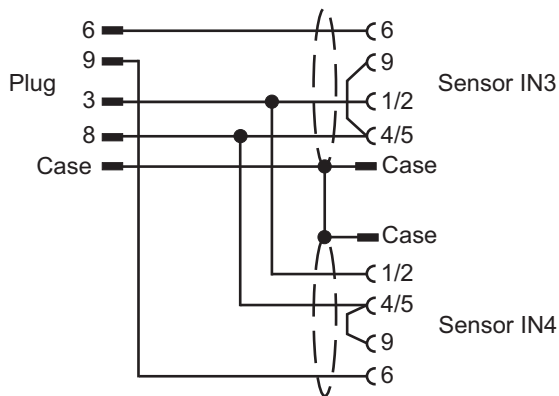

Adapter cable model A

Plug	Assignment	Sensor
3	+ sensor excitation 15 / 24 V	1 / 2
6	+ IN3 signal	6 (IN3)
8	reference ground 15 V / 24 V / signal	4 / 5 / 9
9	+ IN4 signal	6 (IN4 9)
Case	Shield	Case

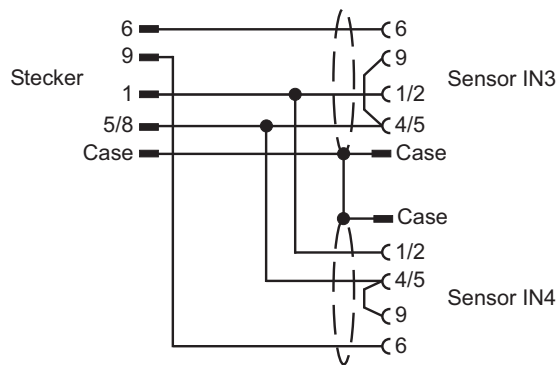

Adapter cable model B

Plug	Assignment	Sensor
1	+ sensor excitation 5 V / 10 V	1 / 2
5 / 8	reference ground 5 V / 10 V / signal	4 / 5 / 9
6	+ IN3 signal	6 (IN3)
9	+ IN4 signal	6 (IN4)
Case	Shield	Case

Optional RS232

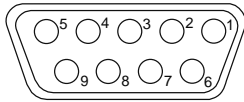

View towards the rear
of the unit

Pin	Assignment
2	Tx
3	Rx
5	GND

Optional RS485

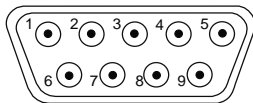

View towards the rear
of the unit

Pin	Assignment
1	- Rx
4	- Tx
6	+ Tx
9	+ Rx

4.2.2 Connections



CAUTION!

Risk of electric shock!

External control circuits connected to the instrument must have Class II insulation.

Note:

All capacitors must be of VDE standard class (class x2) and capable of withstanding a voltage of at least 230 V AC. The maximum power dissipation capacity of the resistor must equal at least 2 W.

Note:

The company of burster präzisionsmesstechnik gmbh & co kg does not accept liability under any circumstances for personal injury or property damage resulting from unauthorized access, improper use or inappropriate operation or use given the technical properties of the unit, or from use that contravenes the instructions given in the present operating manual.

Follow these instructions when connecting the unit:

- Arrange the input leads separately from the leads for the power supply, and from the outputs and main power lines.
- Use twisted/screened cable with its shield grounded at least at one end.
- For output lines that are switched under load (circuit breakers, solenoid valves, motors, fans etc.), connect an RC element (resistor and capacitor in series) in parallel with the load.

This will suppress interference emissions.

- For an inductive load, connect a type 1N4007 diode in parallel with the load.

Input IN1 / IN2 strain gauge sensor, 4-wire

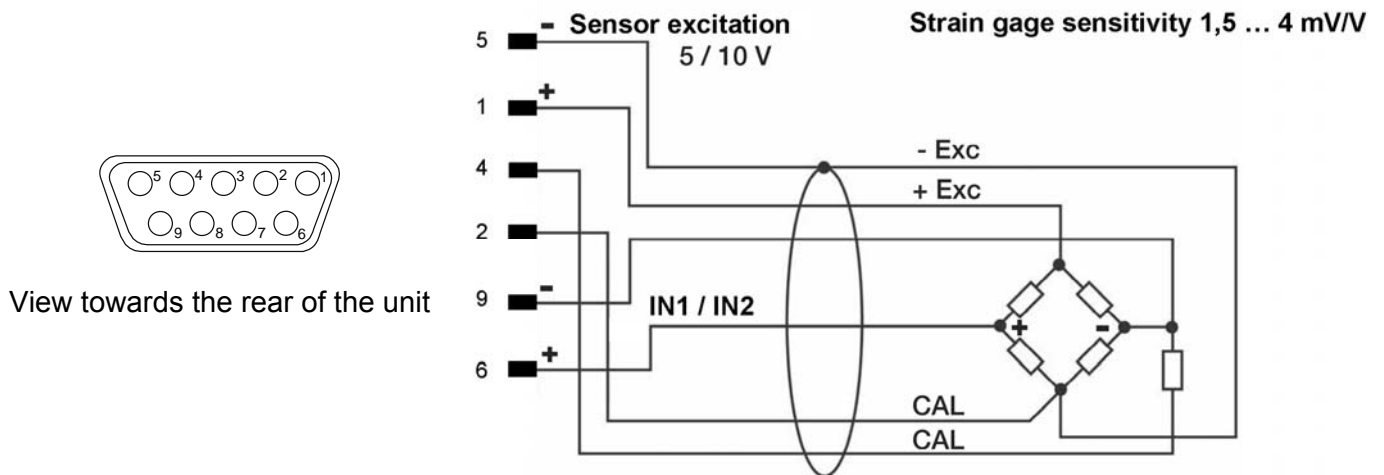

Note:

The test and calibration report for the sensor will specify the size of the calibration resistor.

Input IN1 / IN2 TC – thermocouple

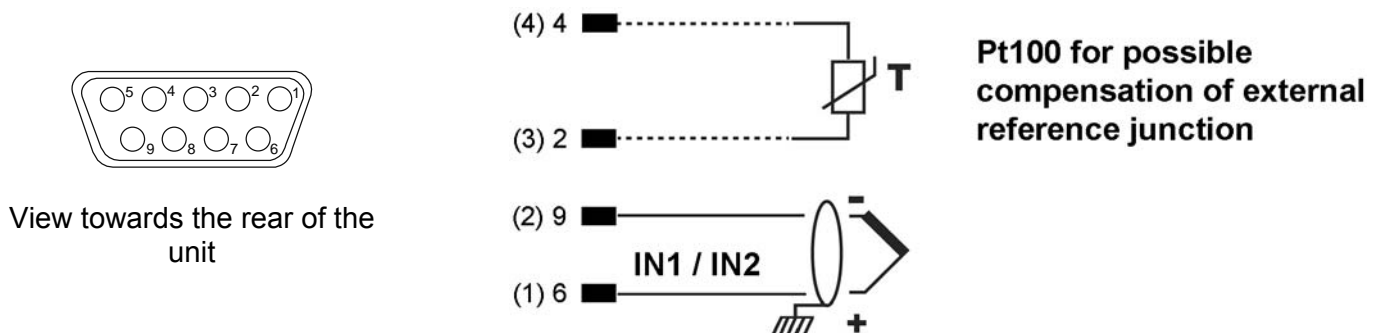

You can connect thermocouples of type J, K, R, S and T.

Following customized linearization, you can also connect thermocouples of type B, E, N, L, U, G, D and C.

- Make sure you connect the polarity correctly.
- Use a suitable compensation line for extending the lead.

Input IN1 / IN2 (voltage)

This input is suitable for a linear DC voltage signal

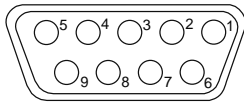

View towards the rear of the unit

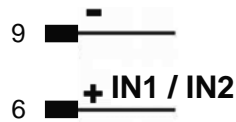

Voltage	Output impedance
±60 mV	>10 MΩ
±100 mV	>10 MΩ
±1.0 V	>2 MΩ
±5.0 V	>2 MΩ
±10.0 V	>2 MΩ

Input IN1 / IN2 potentiometer

Note:

The pin assignment for connecting a potentiometer differs between a single-channel and two-channel instrument!

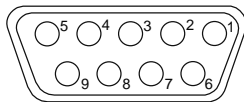

View towards the rear of the unit

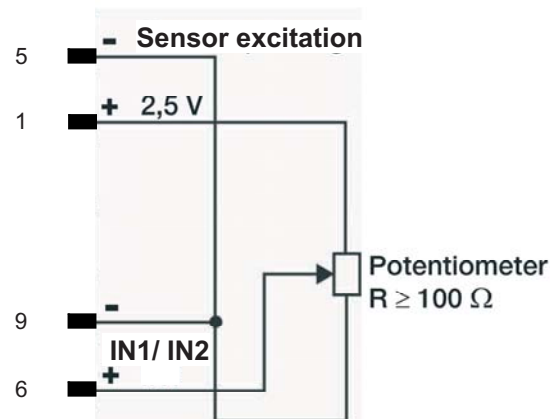

Adapter cable for connecting potentiometers with a burster standard connection to the two-channel unit:

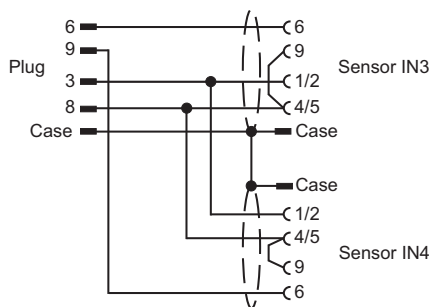

Adapter cable model A

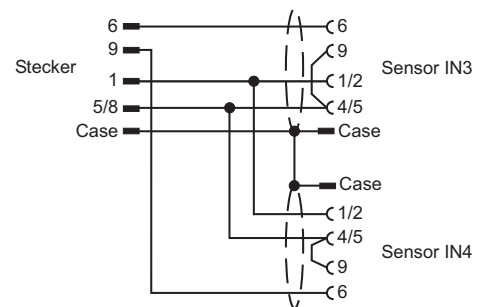

Adapter cable model B

Input IN1 / IN2 PT100

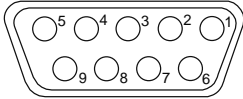

View towards the rear of the unit

2-wire connection

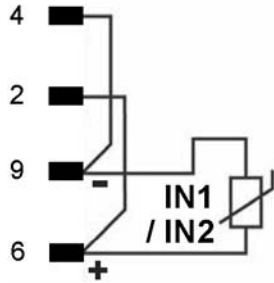

3-wire connection

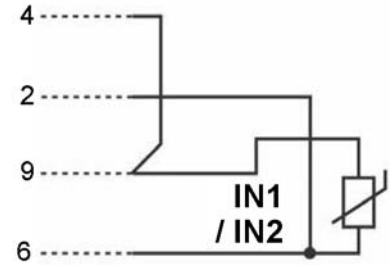

Note:

Only use connecting leads with a suitable cross-section i.e. > 1 mm².

Inputs IN3 / IN4 connected to 3-wire transmitter with excitation supplied by unit

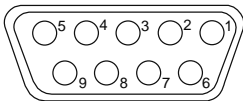

View towards the rear of the unit

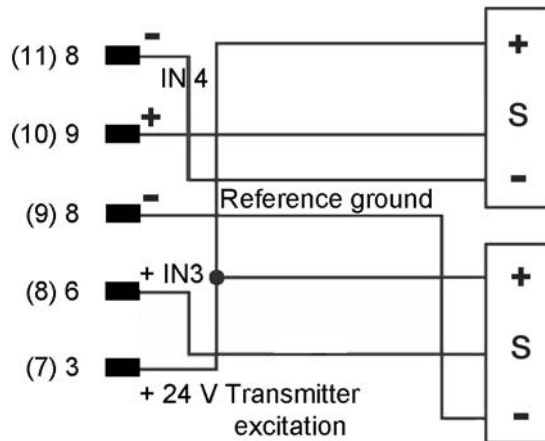

Inputs IN3 / IN4 connected to 2-wire transmitter with excitation supplied by unit

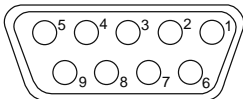

View towards the rear of the unit

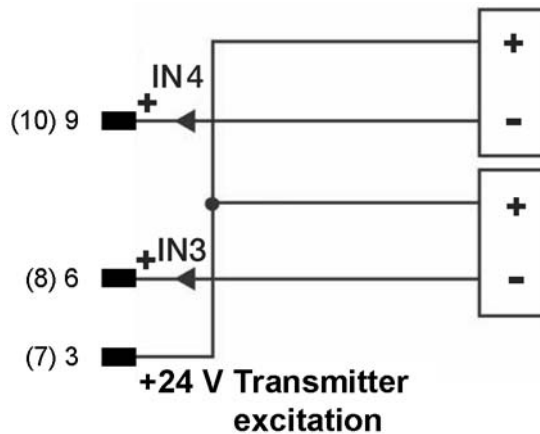

Inputs IN3 and IN4 (current)

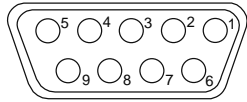

View towards the rear of the unit

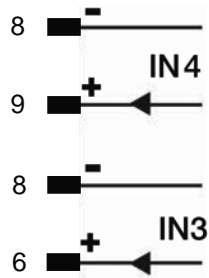

Inputs IN3 and IN4 (voltage)

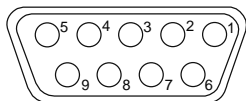

View towards the rear of the unit

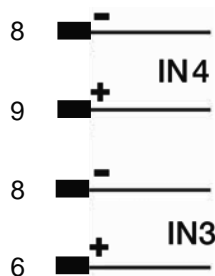

Inputs IN3 and IN4 potentiometer

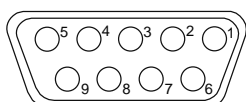

View towards the rear of the unit

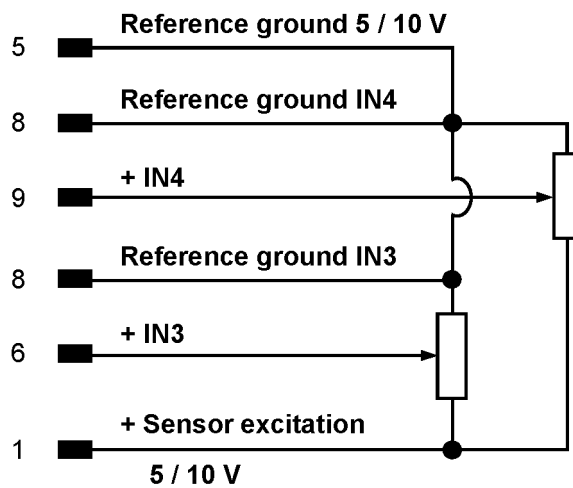

Connection to the analog output

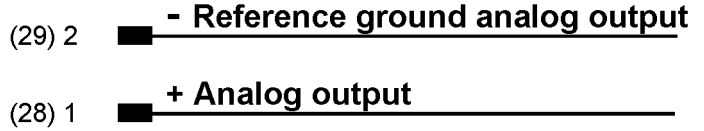
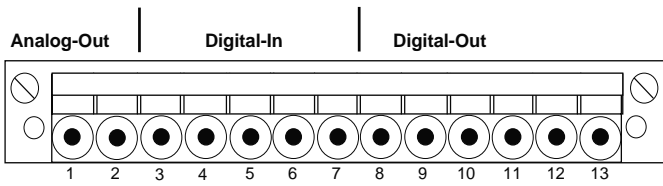

View towards the rear of the unit

You have the following options:

0 – 10 V, 2 – 10 V, ± 10 V, max. 25 mA short-circuit protected

0 – 20 mA, 4 – 20 mA for a maximum load of 500 W

Use configuration parameters to select the type.

Digital inputs DI1 and DI2

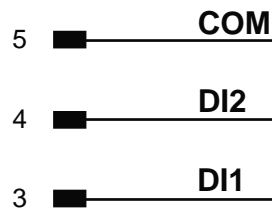
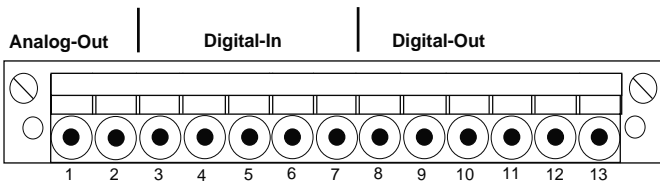

View towards the rear of the unit

Digital inputs (PNP): 24 V, maximum 5 mA (factory default).

Isolated contact (NPN): maximum 5 mA (Hd1).

Use the parameters $d_{i5.x}$, in menu $H-d$ to enable the digital inputs DI1 and DI2.

You can find further information in section 12.3.3: "Digital inputs" on page 113.

Outputs OUT1, OUT2, OUT3 and OUT4

Relay: 5 A, 250 V AC / 30 V DC

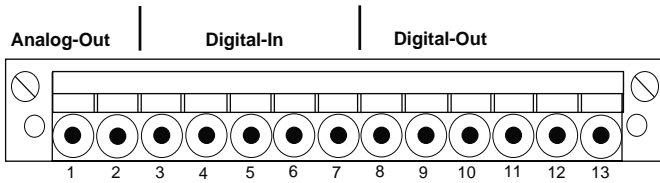

View towards the rear of the unit

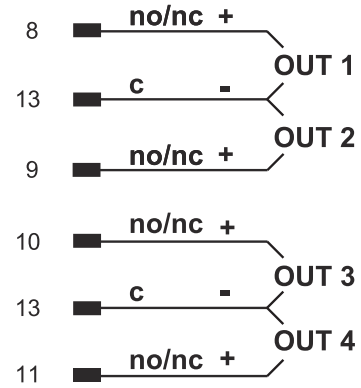

Digital outputs

(N switching, NPN)

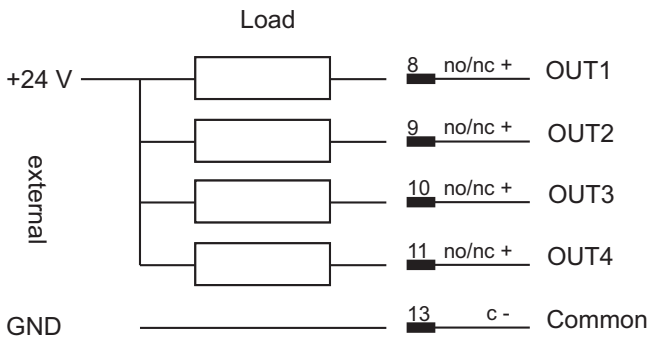

(P switching, PNP)

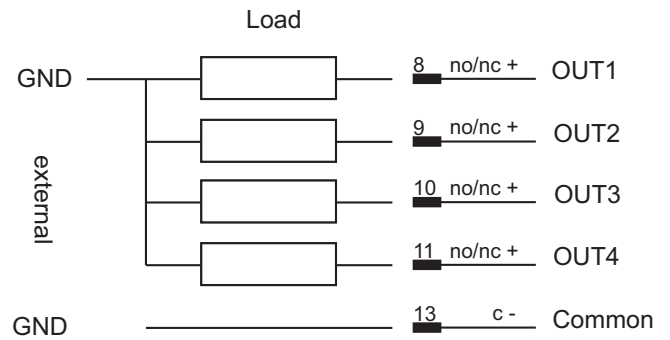

Serial interface: RS232

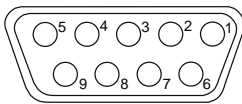

View towards the rear of the unit

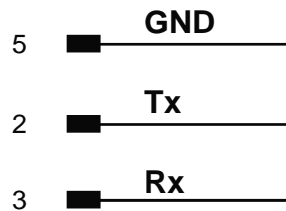

Serial interface: RS485 2-wire (standard):

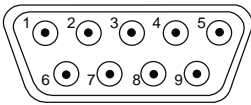

View towards the rear of the unit

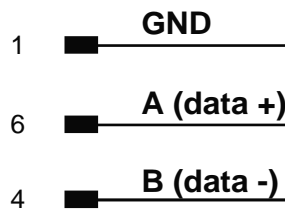

Serial interface: RS485 4-wire

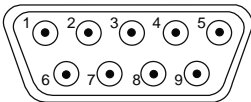

View towards the rear of the unit

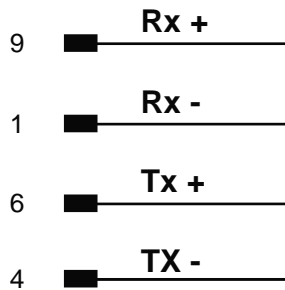

5. Controls

All the controls are grouped on the instrument front panel (degree of protection: IP54).

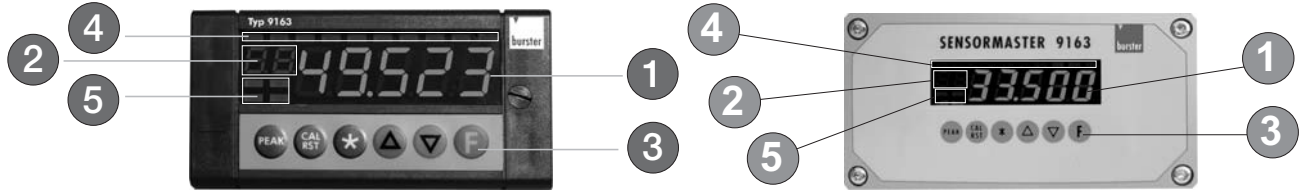

Table 2: User interface

No.	Description	Function										
1	PV display (Process Value display)	Displays the actual value, menu name, parameter name and error codes.										
2	Sub-display	Displays the index value for the process value shown on the PV display; the units are specified in the configuration.										
3	Cursor buttons ▲ ▼	Increments/decrements the parameter values as far as the maximum/minimum value. Holding the button down speeds up the rate at which the displayed value is incremented/decremented.										
	[F] button	Switches between the various menus and parameters. Confirms the current parameter value (or modified parameter value) and opens the next parameter.										
	[PEAK] button	Enables maximum peak value for input IN1 (factory default)	These functions are only enabled when the display is showing the actual value in level 1 (for configuration see the parameters <i>but 1</i> , <i>but 2</i> , <i>but 3</i> in menu <i>Hrd</i>)									
	[CAL RST] button	Checks the strain gauge calibration for input IN1 (factory default)										
	[*] button	Tare (factory default)										
	[F]+[*] buttons	Confirms the current parameter value (or the parameter value modified using the ▲ ▼ buttons) and opens the previous parameter.										
4	AL1 to AL4	Status display for alarm limits: ON (illuminated) OFF (not illuminated)										
5	L1 to L4	Status display for functions; for configuration see parameters <i>LEd. 1</i> , <i>LEd. 2</i> , <i>LEd. 3</i> , <i>LEd. 4</i> in menu <i>Hrd</i>										
		<table border="0"> <tr> <td>L1 = ON</td> <td>Display maximum peak value, IN1</td> </tr> <tr> <td>L2 = ON</td> <td>Monitors automatic calibration, IN1</td> </tr> <tr> <td>L3 = ON</td> <td>(DI1 enabled) replicate DI1</td> </tr> <tr> <td>OFF</td> <td>(DI1 disabled)</td> </tr> <tr> <td>L4 = ON</td> <td>(DI2 enabled) replicate DI2</td> </tr> <tr> <td>OFF</td> <td>(DI2 disabled)</td> </tr> </table>	L1 = ON	Display maximum peak value, IN1	L2 = ON	Monitors automatic calibration, IN1	L3 = ON	(DI1 enabled) replicate DI1	OFF	(DI1 disabled)	L4 = ON	(DI2 enabled) replicate DI2
L1 = ON	Display maximum peak value, IN1											
L2 = ON	Monitors automatic calibration, IN1											
L3 = ON	(DI1 enabled) replicate DI1											
OFF	(DI1 disabled)											
L4 = ON	(DI2 enabled) replicate DI2											
OFF	(DI2 disabled)											



6. Power-up

Optimum performance of the instrument depends on configuring and setting the control parameters correctly.

The versatility and high performance of these instruments is achieved by setting a large number of parameters. These can either be preset directly using the buttons on the control panel, or by downloading a configuration file using the DigiVision software, for which you need the optional RS232 interface.

The DigiVision software only lets you configure the digital indicator. To capture sensor readings you need to purchase the 9163-P100 software.

6.1 Self-diagnosis

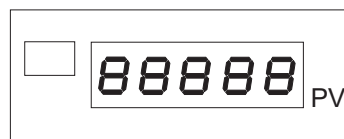

Figure 7: Self-test

The instrument performs a self-test immediately after power-up. During this test, all segments of the display and the 7 LEDs flash.

If the instrument passes the self-test successfully, it switches to normal operating mode (Main menu / level 1).

If the self-test identifies a fault, an error code is displayed. This error code is also saved in the parameter *Err* in the menu *Inf*.

The error codes and their meanings are listed in section: 6.3 "Errors during measurement mode" on page 58.

6.2 Measurement mode

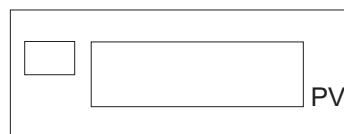

Figure 8: PV, displays the actual value.

You can cycle through each of the channels and the alarm limits by pressing the [F] button briefly to display their values on the PV display. These are used to define the operation of the instrument in the main menu.

You can use the ▲ and ▼ buttons to increment or decrement the selected limit to the required value.

Holding down the [F] button for 3 seconds returns you to the main menu.

You can switch between net and gross values using the keyboard or the digital inputs. When the gross value is being displayed, the decimal point flashes beside the units digit.

You can find further information on operating the unit in section 7: "Basic operation" on page 59.

6.3 Errors during measurement mode

If errors occur during measurement use, the "PV" display shows an error code.

Table 3: Error codes and their meanings

Error code	Meaning
<i>Lo</i>	The actual value is less than the lower scale value (parameter <i>LoS</i> in menu <i>IP</i>)
<i>Hi</i>	The actual value is greater than the upper scale value (parameter <i>HiS</i> in menu <i>IP</i>)
<i>Err</i>	Input short-circuited, or readings at input below the minimum values (e.g. because thermocouple connected incorrectly). The 4... 20 mA transmitter is faulty or has no excitation.
<i>Sbr</i>	Broken sensor or the input signal is greater than the upper scale value.
<i>Ebr</i>	No sensor excitation (strain gauge), sensor faulty or not connected.
<i>Ebr.Lo</i>	No supply voltage to sensor.
<i>Errtd</i>	Third wire of Pt100 sensor broken or not connected.
<i>E.CAL.x</i>	Calibration error at input x (x = 1...4).

You can find further information in section: 15.3 "Troubleshooting" on page 142.

7. Basic operation

7.1 Accessing a specific menu

- In the main menu, hold down the [F] button.

The PV display cycles through the titles of the enabled menus.

Which menus are enabled depends on a jumper on the CPU card and on the parameter-lock setting.

Once you have reached the menu you require:

- Release the [F] button.

You are now in the menu you require.

7.2 Accessing the parameters in the menu

Once you are in the right menu:

- Press (but do not hold down) the [F] button.

This takes you through the individual menu options (parameters) until you get to the parameter you are looking for.

The display now toggles between the parameter name and its corresponding value.

7.3 Adjusting a parameter value

As soon as you have reached a particular parameter, the display starts to flash. You see alternately the name and the current value of the parameter.

- Hold down one of the two buttons ▲ or ▼.

The display now shows the current parameter value, which you are adjusting either up or down.

The instrument starts with a small step size e.g. "1". This step is automatically increased by a power of ten once ten values have been stepped through. So in our example, the step size "1" changes first to "10" then "100" etc.

Once you have adjusted the parameter to the value you require:

- Press (but do not hold down) the [F] button to confirm it.

Changing to a lower step size:

- Release the ▲ or ▼ button.

The display now toggles between the parameter name and the parameter value.

- Wait until the parameter name has been displayed at least once.
- Continue to adjust the value as before.

After another ten values, the instrument again switches to a higher step size.

7.4 Returning to the main menu

- Press the [F] and [★] buttons simultaneously.

You are taken directly back to the main menu.

7.5 Operating hierarchy

7.5.1 Level 1

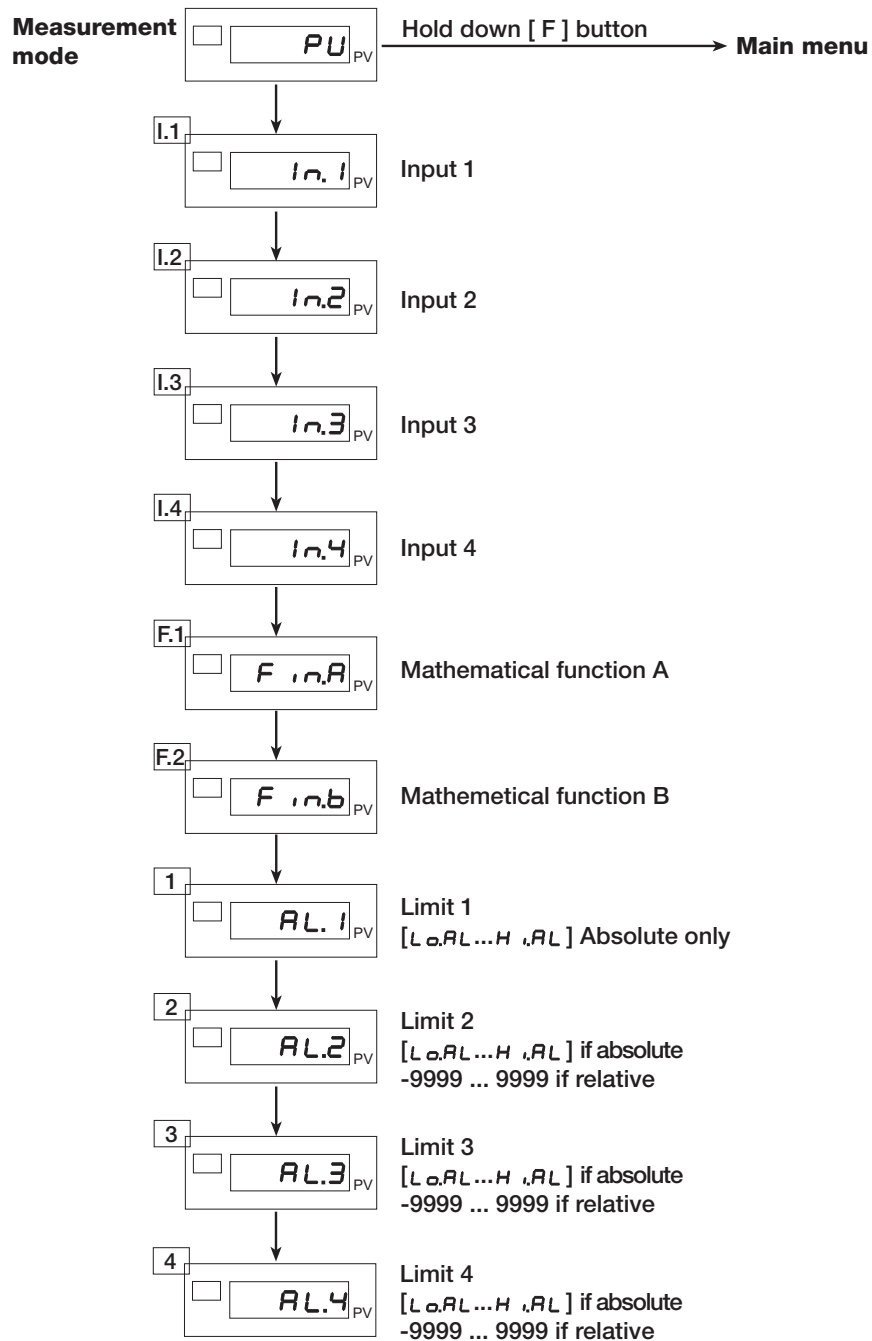

Figure 9: Diagram showing structure of level 1

7.5.2 Main menu

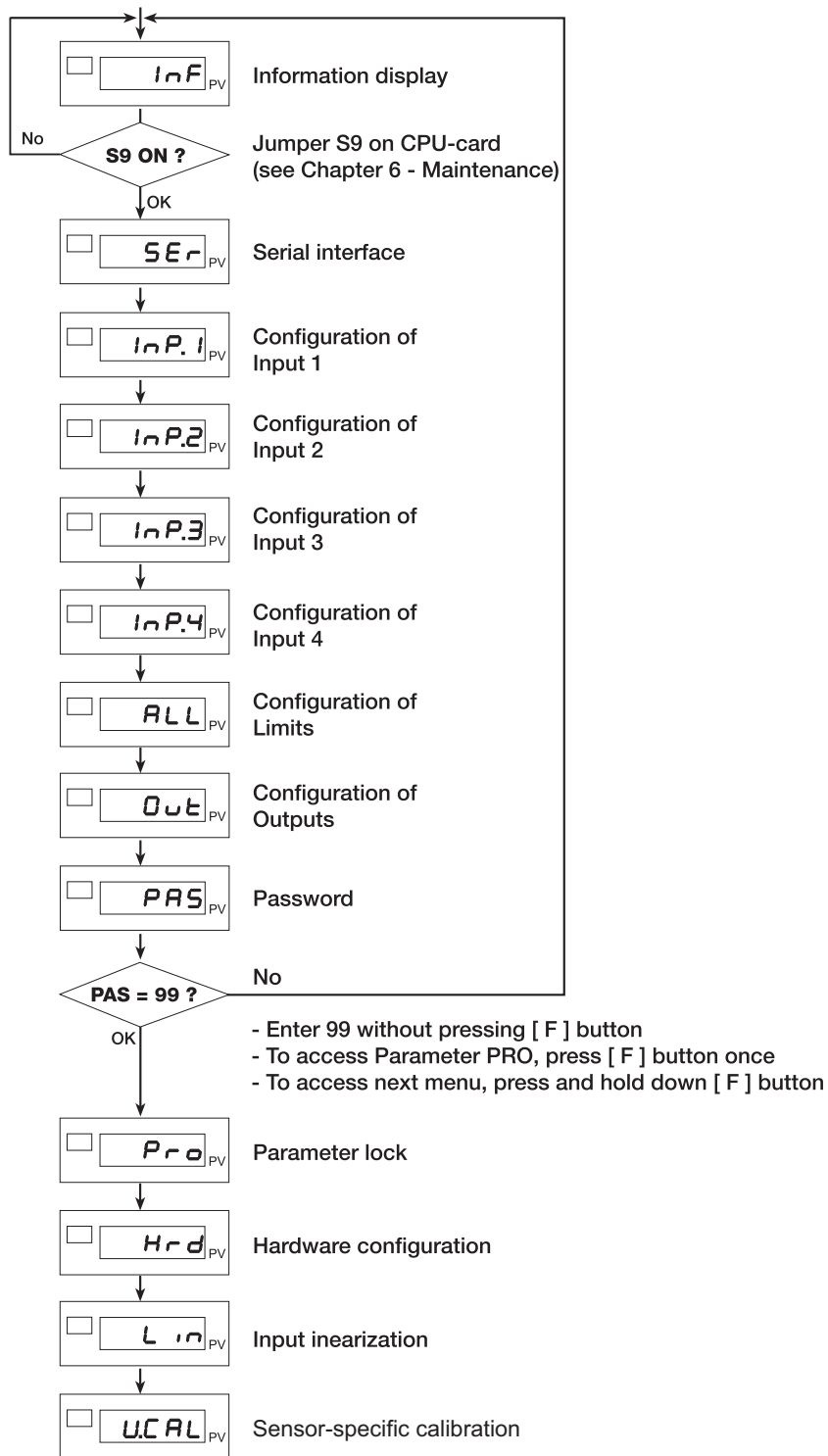

Figure 10: The main menu

Note:
 You can toggle the display of menu parameters using parameters in the hardware configuration Parameters and menus that are not needed are **hidden**. If the ▲, ▼ or [F] buttons are not pressed within 15 s, the display returns to level 1.

8. Retrieving information on the current status

8.1 Displaying the software version

- Switch from the main menu into the menu *Inf*.

To do this, hold down the [F] button until *Inf* is displayed.

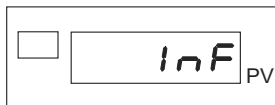

- Press the [F] button briefly once.

You are now at the parameter *UPd*.

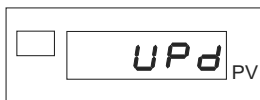

The display now toggles between the parameter name "*UPd*" and the software version.

8.2 Displaying the equipment code

- Switch from the main menu into the menu *Inf*.

To do this, hold down the [F] button until *Inf* is displayed.

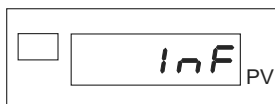

- Go to the parameter *Cod*.

To do this, press the [F] button briefly several times until *Cod* is displayed.

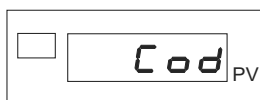

The unit now toggles between the parameter name "*Cod*" and the equipment code.

8.3 Displaying the error code for a specific input

- Switch from the main menu into the menu *lnF*.

To do this, hold down the [F] button until *lnF* is displayed.

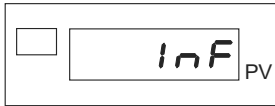

- Go to the relevant parameter *Err*.

To do this, press the [F] button briefly several times until *Err* is displayed.

The menu *lnF* contains the parameters labeled *Err 1* to *Err 4* that hold the error codes for the four inputs.

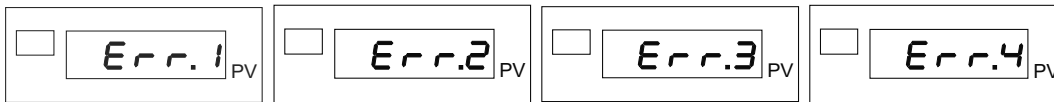

The error codes for the mathematical functions *Fin.A* and *Fin.b* are held by parameters *Err 5* and *Err 6*.

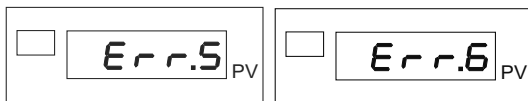

You can find further information on the functions *Fin.A* and *Fin.b* in section 12.3.1: "Mathematical functions" on page 105.

The unit now toggles between the parameter name "*Err*" and one of the error codes from the following table.

Error code	Meaning
0	No error at this input.
1	The actual value is less than the lower scale value (parameter <i>LoS</i> in menu <i>lnP</i>)
2	The actual value is greater than the upper scale value (parameter <i>HiS</i> in menu <i>lnP</i>).
3	Input short-circuited, or readings at input below the minimum values (e.g. because thermocouple connected incorrectly). The 4 ... 20 mA transmitter is faulty or has no excitation.
4	Broken sensor or the input signal is greater than the upper scale value.
5	No sensor excitation (strain gauge), because sensor is faulty or not connected.
6	No supply voltage to sensor.
7	Third wire of Pt100 sensor broken or not connected.
8	Calibration error at input x (x = 1 ... 4).

8.4 Displaying the position of the decimal point

- Switch from the main menu into the menu *lnF*.

To do this, hold down the [F] button until *lnF* is displayed.

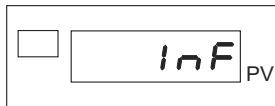

- Go to the parameter *dPS.5*.

To do this, press the [F] button briefly several times until *dPS.5* is displayed.

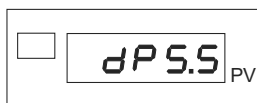

This parameter contains the position of the decimal point for the mathematical function Fin.A.

- Press the [F] button briefly.

You are now at parameter *dPS.6*.



This parameter contains the position of the decimal point for the mathematical function Fin.b.

You can find further information on the functions Fin.A and Fin.b in section 12.3.1: "Mathematical functions" on page 105.

8.5 Displaying the scale values

- Switch from the main menu into the menu *Inf*.

To do this, hold down the [F] button until *Inf* is displayed.

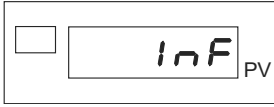

- Go to the parameter *Lo5.5*.

To do this, press the [F] button briefly several times until *Lo5.5* is displayed.

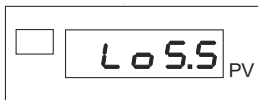

This contains the lower scale value for the mathematical function Fin.A.

- Switch to the parameter *Lo5.6*.

To do this, press the [F] button briefly.

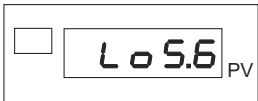

This contains the lower scale value for the mathematical function Fin.b.

- Switch to the parameter *Hi5.5*.



This contains the upper scale value for the mathematical function Fin.A.

- Switch to the parameter *Hi5.6*.

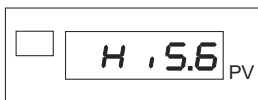

This contains the upper scale value for the mathematical function Fin.b.

You can find further information on the functions Fin.A and Fin.b in section 12.3.1: "Mathematical functions" on page 105.

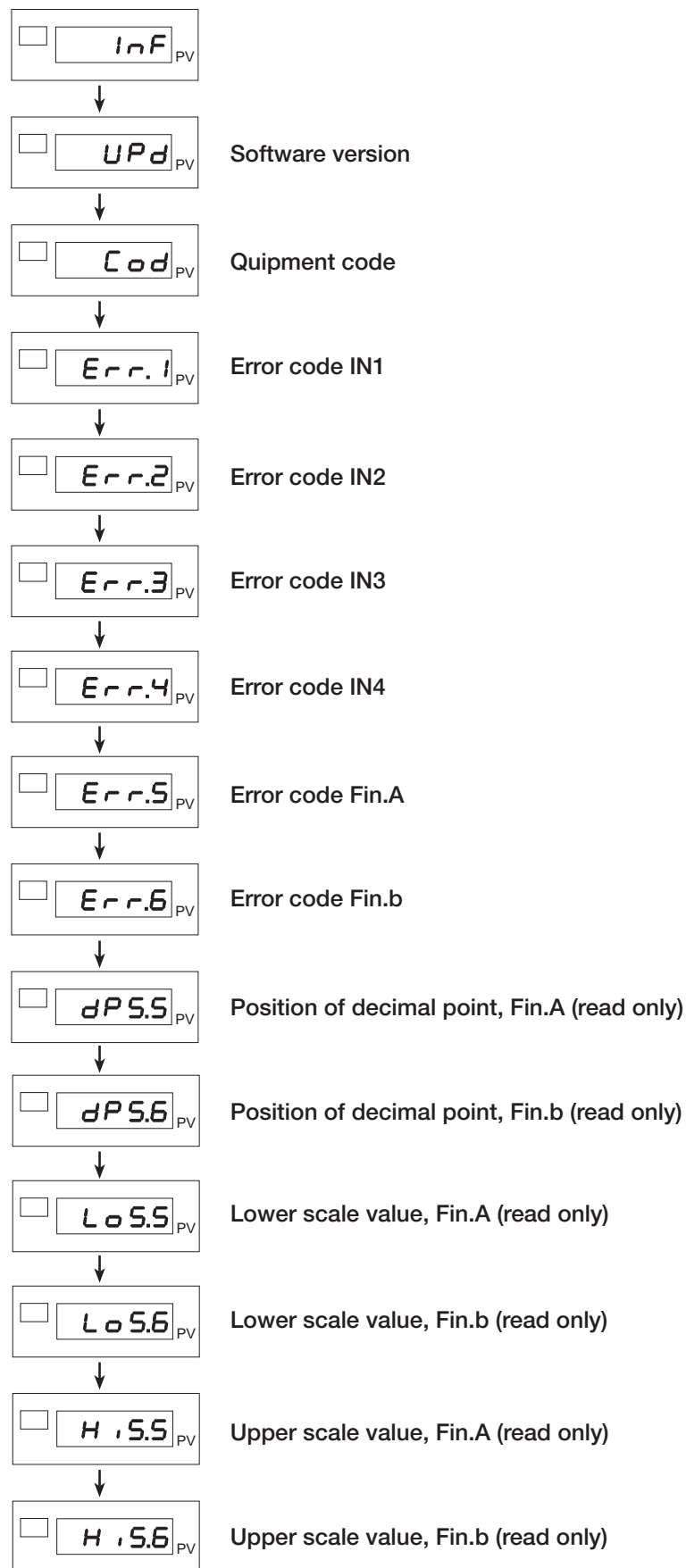



Figure 11: The Information menu in full



9. Input configuration

The advanced Configuration / Parameterization menus for the 9163 digital indicator contain parameters that let you define the finest points of the instrument configuration. This means that the digital indicator can satisfy the requirements of practically any application.



WARNING!

Warning of personal injury and property damage!

Make sure that all the parameter sets are correct before operating the instrument.

The following pages provide information on the various menus of the 9163 indicator in turn. Each parameter is accompanied by details of its function, its default value if any, and the limits within which it can be set.

Note:

Please refer to the values in the tables when setting parameters. For some parameters you also need to add on values to obtain certain functions.

9.1 Configuring a main input

You configure the two main inputs of the 9163 digital indicator in the menus *I nP. 1* and *I nP. 2*. Both menus have an identical structure and the same settings. Each menu contains the settings for one main input.

- Switch from the main menu into the relevant configuration menu (*I nP. 1* or *I nP. 2*).

To do this, hold down the [F] button until *I nP. 1* or *I nP. 2* is displayed.

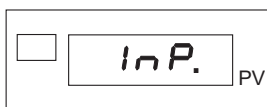

- Press the [F] button briefly once.

You are now at the parameter *tYP.*

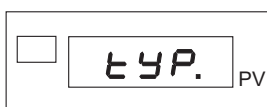

- Set a specific sensor type for the input by entering the sensor class.

The following sensor types are possible:

Class	Sensor type	Scale value
0	Input disabled	
1	TC J °C	0 / 1000
2	TC J °F	32 / 1832
3	TC K °C	0 / 1300
4	TC K °F	32 / 2372
5	TC R °C	0 / 1750
6	TC R °F	32 / 3182
7	TC S °C	0 / 1750
8	TC S °F	32 / 3182
9	TC T °C	-200 / 400
10	TC T °F	-328 / 752
11	PT100 °C	-200 / 850
12	PT100 °F	328 / 1562
13	Potentiometer $\geq 100 \Omega$, supply voltage 2.5 V	-19999 / 99999
14	Strain gauge sensors with positive polarization. Sensitivity: 1.5 to 4 mV/V	-19999 / 99999
15	Strain gauge sensors with symmetric polarization. Sensitivity: 1.5 to 4 mV/V	-19999 / 99999
16	60 mV	-19999 / 99999
17	± 60 mV	-19999 / 99999
18	100 mV	-19999 / 99999
19	± 100 mV	-19999 / 99999
20	1 V	-19999 / 99999
21	± 1 V	-19999 / 99999
22	5 V	-19999 / 99999
23	± 5 V	-19999 / 99999
24	10 V	-19999 / 99999
25	± 10 V	-19999 / 99999
26	0 to 20 mA / 4 to 20 mA	-19999 / 99999
27	Do not use!	
28	Strain gauge sensors, positive polarization, calibrated, 40mV	-19999 / 99999
29	Strain gauge sensors, symmetric polarization, calibrated, 40mV	-19999 / 99999

Add-on functions:

- +32 for a sensor-specific linearization.
- +64 for thermocouples with external compensation element.

Note:

You can use class settings 28 and 29 without calibrating the sensor. Set the required parameters for offset and sensitivity.

For class settings 28 and 29, a 10 V supply voltage corresponds to maximum sensitivity of 4 mV/V.

Once you have set the sensor class:

- Press the [F] button briefly.

The display now shows the parameter *F It.*

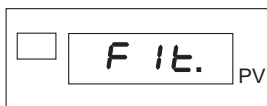

You use this parameter to set the digital filter for the input concerned.

You can set the filter in a range between 0.00 and 20.00 seconds.

Note:

The digital filter *F It.* is a display filter, i.e. it affects the display.

Note:

Set the digital filter to the value "0" to disable it.

Once you have set the digital filter:

- Press the [F] button briefly.

You are now at the parameter *dPS.*

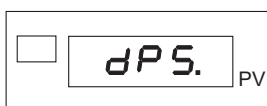

This parameter is used to set the position of the decimal point.

- Use the following codes to set the position of the decimal point.

Only positions "0" and "1" are available for thermocouples.

Code	Format
0	0 0 0 0 0
1	0 0 0 0 . 0
2	0 0 0 . 0 0
3	0 0 . 0 0 0
4	0 . 0 0 0 0

Add-on functions:

If it is a linear input:

- +8 disables the message **L₀** and **H₁** (linear inputs only).
- +16 disables the message **Ebr** (only for sensors type 0 to 15 and for Sensors type 28 and 29)
- +32 for linear differential inputs (16...25)

Once you have set the position of the decimal point for this input:

- Continue by setting the upper and lower scale values.

To do this, press the [F] button.

The display now shows the parameter **L₀S**.

That is the adjustment's lower scale value.

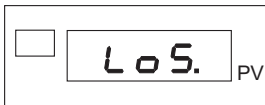

- Set the lower scale value.

Once you have set the lower scale value:

- Press the [F] button briefly.
- Repeat the procedure for the upper scale value.

The display shows the parameter **H₁S**.

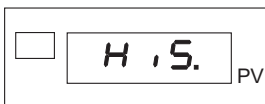

- Confirm the upper scale value with the [F] button.

The display now shows the parameter **OF₅**.

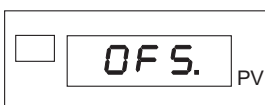

- Specify the correction offset for this input.

The correction offset can lie between -999 and +999 scale divisions.

- Confirm with the [F] button.

If you have set the parameter **LYP** to a sensor of class "28" or "29", you can now specify the sensitivity and the offset.

Otherwise you skip these steps.

You have now reached the parameter **SCOF** (offset) (only for sensors of class "28" and "29").



- Now set the offset.

This can lie between -9.999 and +9.999 mV.

Once you have made the setting:

- Press the [F] button briefly to confirm it.

The parameter **SCSE** is used for setting the sensitivity (only for sensors of class "28" and "29").

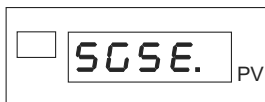

- Press the [F] button briefly.

Configuration of this input is now complete and you are back in the main menu.

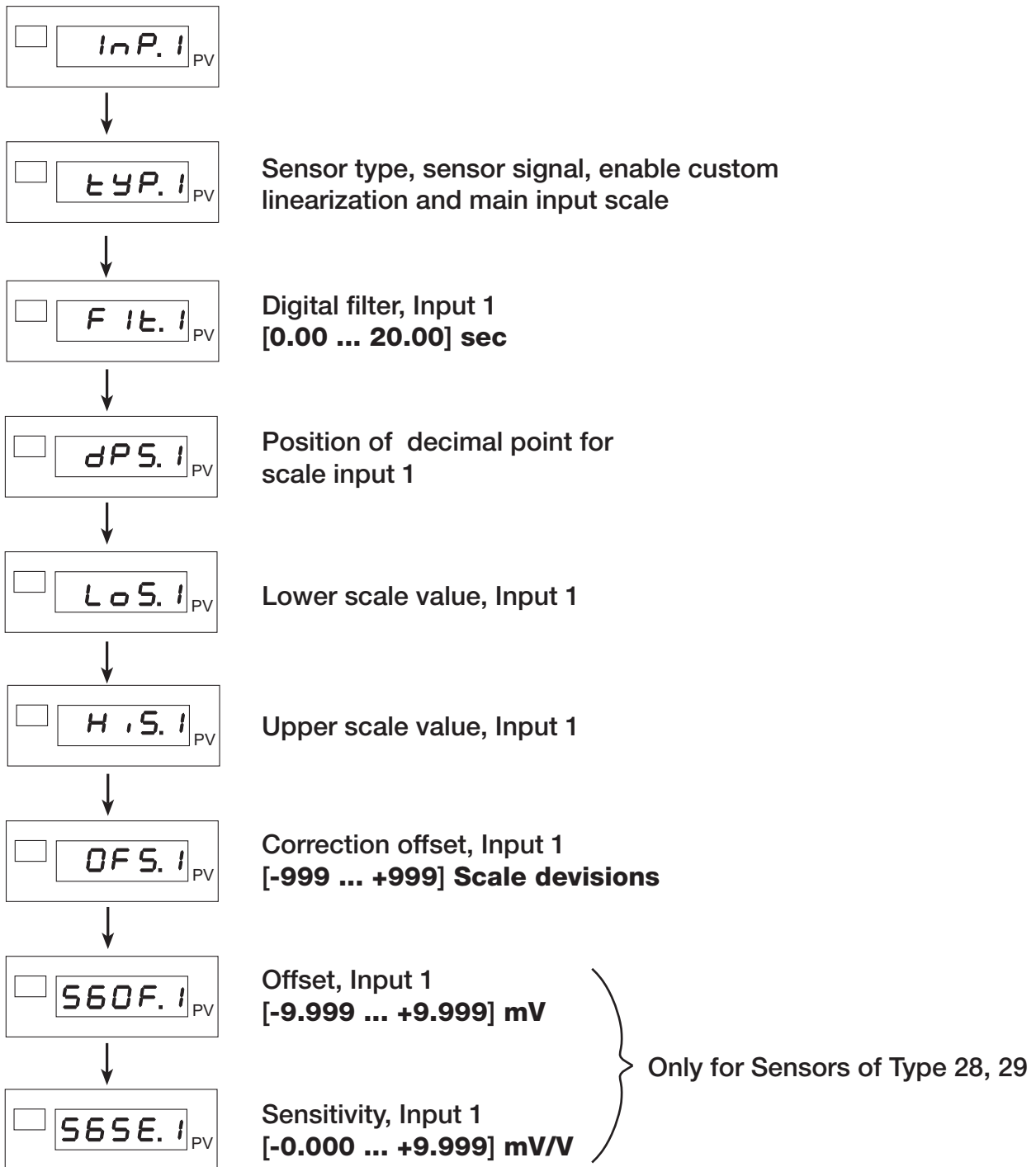

Figure 12: Configuring a main input using the example of *InP.1*.

9.2 Configuring an auxiliary input

You configure the two auxiliary inputs of the digital indicator using the menus *I n P.3* and *I n P.4*. Both menus have an identical structure and the same settings. Each menu contains the settings for one auxiliary input.

- Switch from the main menu into the relevant configuration menu (*I n P.3* or *I n P.4*).

To do this, hold down the [F] button until *I n P.3* or *I n P.4* is displayed.

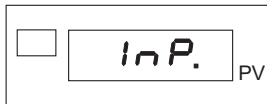

- Press the [F] button briefly once.

You are now at parameter *t Y P.*

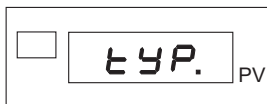

- Set a specific sensor type for the input by entering a sensor class.

The following sensor types are possible:

Class	Sensor type	Scale value
0	Input disabled	
1	0 to 10 V	-19999 / 99999
2	0 to 20 mA / 4 to 20 mA	-19999 / 99999
3	Do not use!	
4	Potentiometer	-19999 / 99999

Add-on function:

- +32 for custom linearization.

Once you have set the type of sensor:

- Press the [F] button briefly.

The display now shows the parameter *F It.*

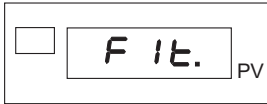

You use this parameter to set the digital filter for the input concerned.

You can set the filter in a range between 0.00 and 20.00 seconds.

Note:

The digital filter *F It.* is a display filter, i.e. it affects the display.

Note:

Set the digital filter to the value "0" to disable it.

Once you have set the digital filter:

- Press the [F] button.

You are now at the parameter *dPS.*

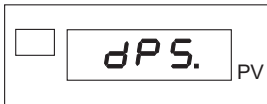

This parameter is used to set the position of the decimal point.

- Use a code to set the position.

Only positions "0" and "1" are available for thermocouples.

Code	Format
0	0 0 0 0 0
1	0 0 0 0 . 0
2	0 0 0 . 0 0
3	0 0 . 0 0 0
4	0 . 0 0 0 0

Add-on function:

- +8 disables the message *L* and *H*.

Once you have set the position of the decimal point for this input:

- Continue by setting the upper and lower scale values.

To do this, press the [F] button.

The display now shows the parameter **LoS**.

That is the adjustment's lower scale value.



- Set the lower scale value.

Once you have set the lower scale value:

- Press the [F] button briefly.

The display shows the parameter **H iS**.

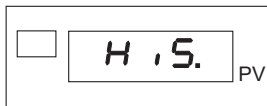

- Repeat the procedure for the upper scale value.
- Confirm the upper scale value with the [F] button.

The display now shows the parameter **OfS**.

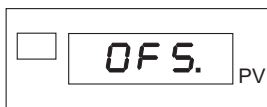

- Enter the correction offset for this input.

The correction offset can lie between -999 and +999 scale divisions.

- Confirm with the [F] button.

Configuration of this input is now complete and you are back in the main menu.

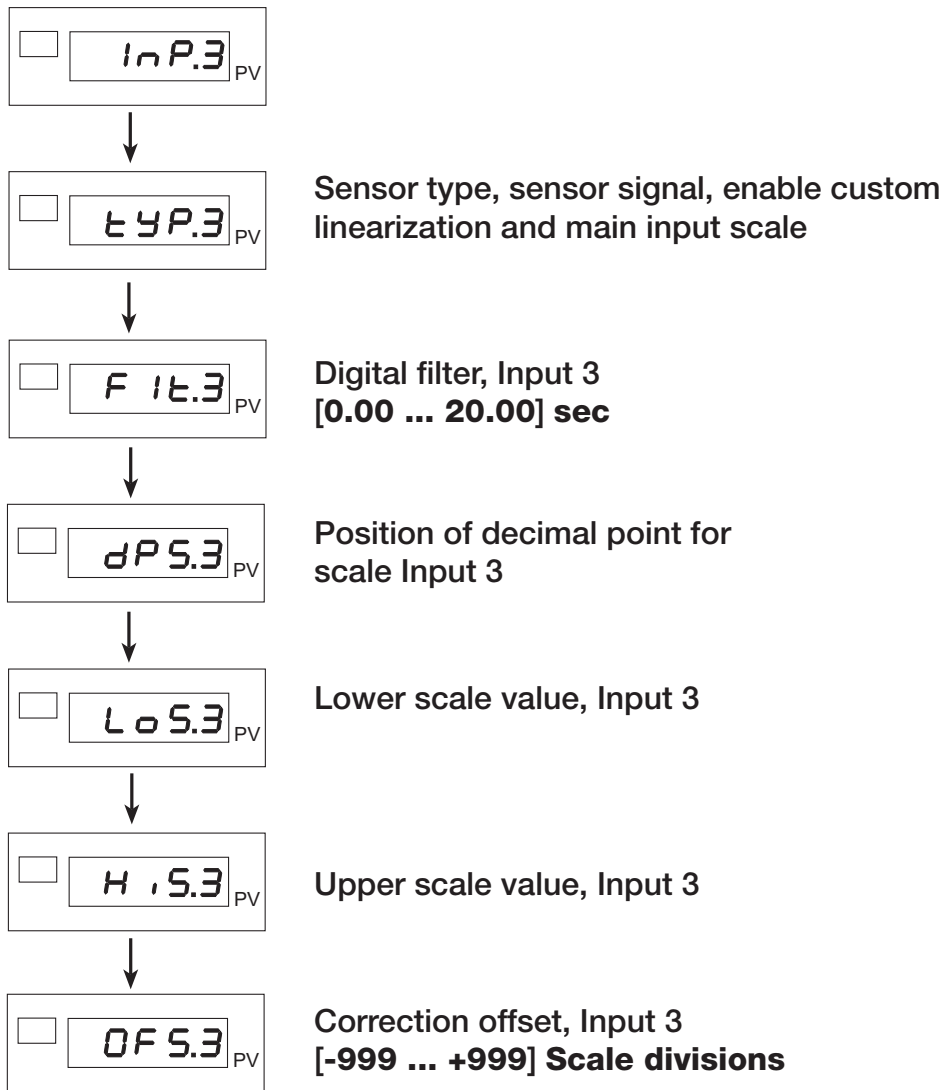
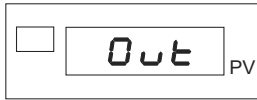

Figure 13: Configuring an auxiliary input using the example of *InP.3*.

9.3 Selecting the sensor excitation

- Open the menu *Out*.

To do this, in the main menu hold down the [F] button until *Out* is displayed.



- Press the [F] button briefly several times until *ALS* is displayed.



- Specify the type of sensor excitation.

The following types of sensor excitation are possible:

Code	Sensor excitation
0	2.5 V for potentiometer (only for input IN1)
1	5 V strain gauge sensors
2	10 V strain gauge sensors

The maximum current is 200 mA.

- Press the [F] button briefly to confirm your selection.

That completes configuration of the outputs. You are now back in the main menu.

9.4 Selecting the transmitter excitation voltage 15 V / 24 V



WARNING!

You will get an electric shock if the voltage is connected!

Disconnect the digital indicator from the power supply before opening the case.



CAUTION!

Risk of damage from electrostatic voltages!

Take suitable precautions when handling the boards.

You set the transmitter excitation voltage using a jumper on the CPU board.

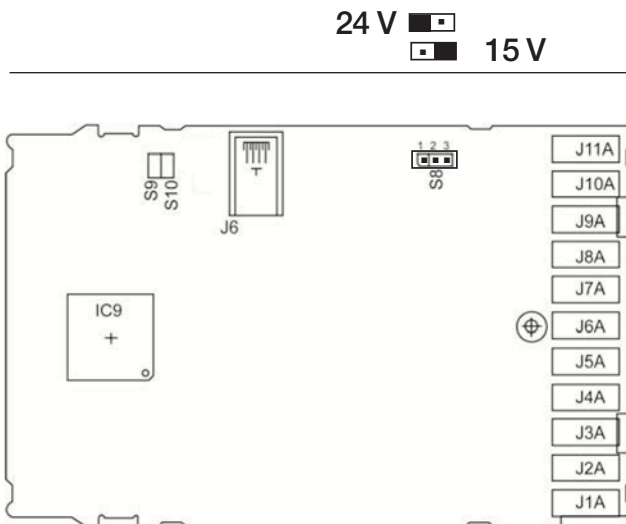

Figure 14: Selecting the transmitter excitation voltage 15 V / 24 V

10. Output configuration

10.1 Specifying the output parameters

Follow these steps:

- Open the menu *Out*.

To do this, in the main menu hold down the [F] button until *Out* is displayed.

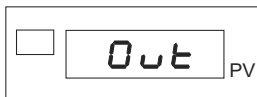

- Press the [F] button briefly.
- The display now shows *rL.1*

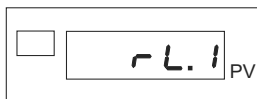

You use this parameter to specify the reference signal for the alarm limit output 1.

- You do this by entering a code.

Code	Function
0	OFF
1	Limit 1 (AL1)
2	Limit 2 (AL2)
3	Limit 3 (AL3)
5	Replicate logic input 1
6	Replicate logic input 2
7	Replicate button <i>bUt.1</i> ([★])

Code	Function
8	AL1 or AL2
9	AL1 or AL2 or AL3
10	AL1 and AL2
11	AL1 and AL2 and AL3
16	or AL3 ... AL4
17	and AL3 ... AL4
18	Limit 4 (AL4)

Add-on function:

- +32 inverts the output concerned.

- Press the [F] button briefly to confirm the code.

This takes you to the parameters for outputs 2 to 4 (parameters *rL.2* to *rL.4*).

- Repeat the procedure to specify the reference signal for these outputs as well.

Once you have specified in parameter *rL.4* the reference signal for the alarm limit output 4, you then reach the parameter *EXP.An*.

10.2 Selecting the analog output

- Open the menu *Out*.

To do this, in the main menu hold down the [F] button until *Out* is displayed.

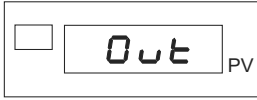

- Press the [F] button briefly several times until *tYP.An* is displayed.

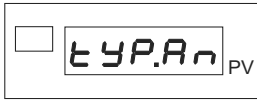

- You use this parameter to specify the type of the analog output (OUT W).

The following settings are possible:

Code	Format
0	Output disabled
1	0 to 10 V
2	2 to 10 V
3	0 to 20 mA
4	4 to 20 mA
5	±10 V

Add-on function:

- +8 to invert.

- Press the [F] button briefly to confirm the type of output.

The display now shows the parameter *r iF.An*.



- Assign a reference variable.

The following settings are possible:

Code	Reference variable
0	IN1
1	IN2
2	IN3
3	IN4
4	Fin.A (Mathematical function A)
5	Fin.b (Mathematical function b)
12	Value acquired via serial port
13	Peak value, Input 1 maximum
14	Peak value, Input 1 minimum
15	Peak-to-peak value, Input 1
16	Peak value, Input 2 maximum
17	Peak value, Input 2 minimum
18	Peak-to-peak value, Input 2
19	Limit 1 (AL1)
20	Limit 2 (AL2)
21	Limit 3 (AL3)

Add-on functions:

- +32 analog output to physical max./min. when input in High/Low state (outside the calibration limits).
- +64 only for $r.i.F.A_n = 0, 1, 2, 3, 4, 5$: Output to minimum when the input is in state Err , Sbr or Ebr .

- Press the [F] button briefly to confirm the reference variable.

The display now shows the parameter $Lo.A_n$.

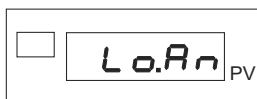

You use this parameter to specify the lower scale value for the analog outputs.

- Enter the lower scale value for the analog outputs.
- Press the [F] button briefly to confirm the value.
- Using the parameter $Hi.A_n$, specify the upper scale value.

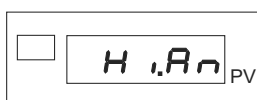

- Press the [F] button briefly to confirm the value.

You are now at the last configuration stage, the sensor excitation (ALS).

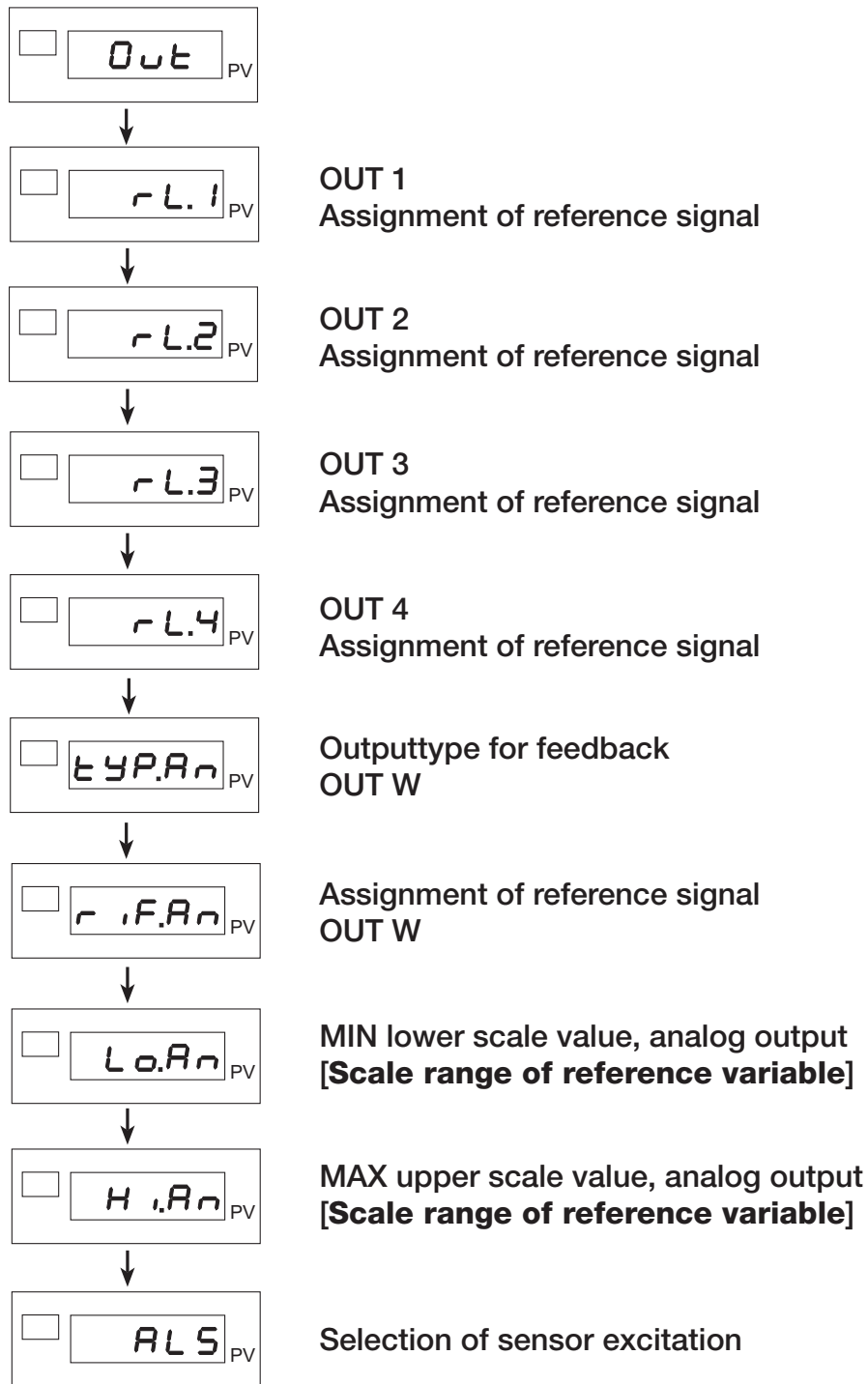

Figure 15: Configuring the outputs

10.3 Fine adjustment of the analog output

Note:

If necessary, you can abort the fine adjustment procedure for the analog output from the parameter **CA.Lo** onwards. To abort the process, hold down the [**★**] + [F] buttons simultaneously. You are then taken back to the parameter **U.CAL**.

- First go to the menu **PAS**.

To do this, hold down the [F] button until **PAS** is displayed.



- Use the ▲ or ▼ buttons to set the value "99".

Once you have set the value, you get access to the protected area.

- Hold down the [F] button until **U.CAL** is displayed.



- Enter the value "7".
- Press the [F] button briefly to confirm this value.

You are now at the parameter **CA.Lo**.

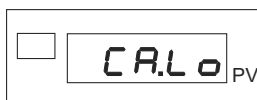

- Enter the minimum value.
- Use the ▲ and ▼ buttons to set the value.
- Press the [F] button briefly to confirm the value.

The display now shows the parameter **CA.H**.

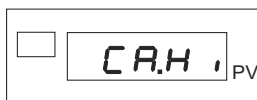

- Enter the maximum value.
- Use the ▲ and ▼ buttons to set the value.
- Press the [F] button briefly to confirm the value.

That completes the fine adjustment of the analog output.

You are now back in the main menu at the top of the menu **U.CAL**.

10.4 Setting alarm limits

Note:

If several alarm limits (having an assigned character string) are being output simultaneously, the alarm limit with the lowest number takes priority (AL1 = highest priority; AL4 = lowest priority).

Absolute limit

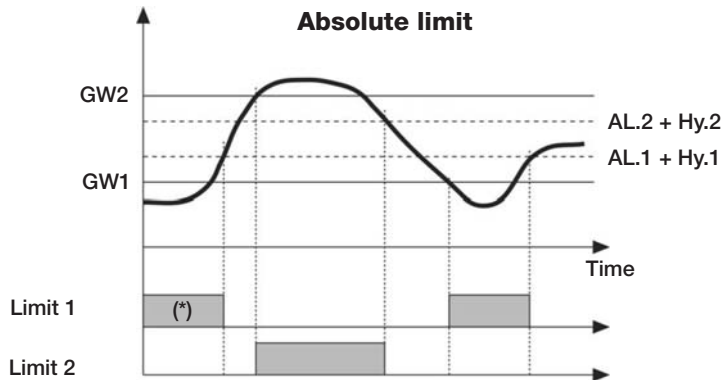

For AL1, inverse absolute limit (undershoot) with positive hysteresis $HY\ 1$, $AL.1 = 1 (*) = 0$. Limit is Off if actuated during power-up phase.

For AL2, direct absolute limit (overshoot) with negative hysteresis $HY\ 2$, $AL.2 = 0$

Symmetric absolute limit

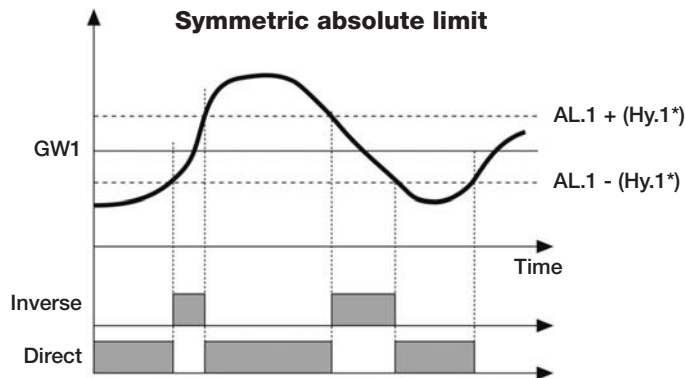

For AL1, absolute inverse symmetric limit with hysteresis $HY\ 1$, $AL.1 = 4$

For AL1, absolute direct symmetric limit with hysteresis $HY\ 1$, $AL.1 = 5$

Note:

The relative alarm is referred to a previous absolute alarm (SP) e.g. AL1 absolute; AL2 = relative, referred to AL1

Relative limit referred to SP (previous absolute limit)

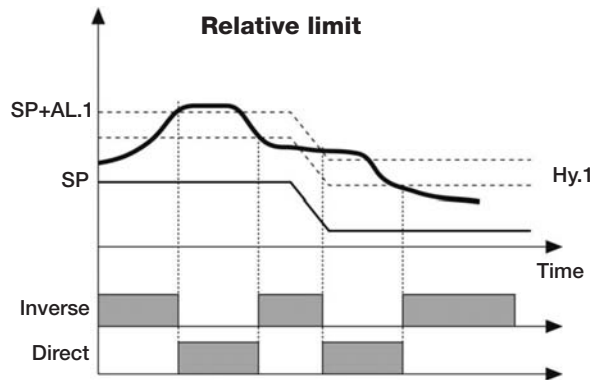

For AL1, relative inverse limit with negative hysteresis $HY\ 1, AL.1 = 3$

For AL1, relative direct limit with negative hysteresis $HY\ 1, AL.1 = 2$

* Minimum hysteresis: 2 scale divisions

Symmetric relative limit referred to SP (previous absolute limit)

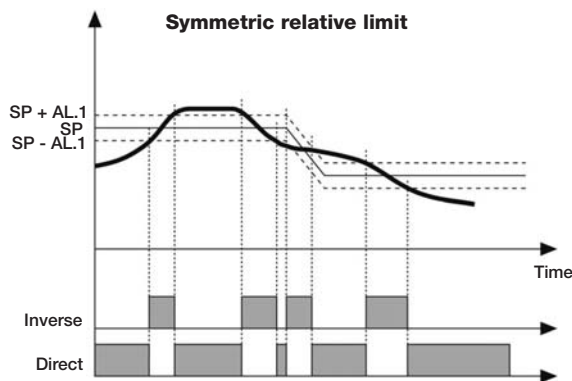

For AL1, relative inverse symmetric limit with hysteresis $HY\ 1, AL.1 = 6$

For AL1, relative direct symmetric limit with hysteresis $HY\ 1, AL.1 = 7$

Note:

For limits that are related ($AL.n = \text{relative}$) to other reference variables ($AR.n$) that have different settings for the decimal point, the response threshold is always based on the scale divisions without taking the decimal points into account. Example: if $AR.n = 0$ (referred to IN1) and $AL.n = 6$ (relative, referred to IN3) and IN1 has $dP = 1$, IN3 has $dP = 2$, $AL1 = 200.0$ IN3 = 10.00, $dS.SP = 1$, the response threshold of the limit is 300.0

10.4.1 Enabling alarm limits

- First go to the menu *PAS*.

To do this, hold down the [F] button until *PAS* is displayed.



- Use the ▲ or ▼ buttons to set the value "99".
- Hold down the [F] button until *Hrd* is displayed.

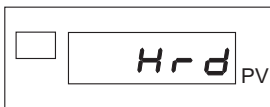

- Press the [F] button briefly several times until *AL.n* is displayed.

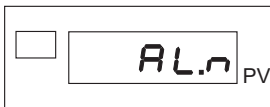

This is used for enabling alarm limits.

- Set the number of alarm limits to be enabled.
- You can enable up to four (4) alarm limits.

After enabling the limits, you can specify the button functions for the control panel. The parameters *but. 1* to *3* are used for this purpose.

10.4.2 Configuring an alarm limit

Before you can configure an alarm limit, you must first enable it. This is done in the menu *Hrd*.

- First switch from the main menu into the menu *PAS*.

To do this, hold down the [F] button until *PAS* is displayed.



- Use the ▲ or ▼ buttons to set the value "99".
- Then hold down the [F] button until *Hrd* is displayed.

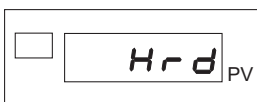

- Press the [F] button briefly several times until **AL.n** is displayed.



- Use the ▲ or ▼ buttons to set the number of alarm limits to be enabled.
You can enable up to four alarm limits.
- Press the [F] button to confirm the value.

This enables a specific number of alarm limits (up to four allowed). All other settings are made in the menu **ALL**.

- Now go to the menu **ALL**.

To do this, hold down the [F] button until **ALL** is displayed.



- Press the [F] button briefly.

You are now at the parameter **Ar.n** ("n" stands for the number of the limit: AL1, AL2 etc.).

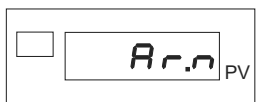

- Use the code to specify the reference variable for the respective limit.

The following reference variables are possible:

Code	Reference variable
0	IN1
1	IN2
2	IN3
3	IN4
4	Fin.A (Mathematical function A)
5	Fin.b (Mathematical function b)
12	Value acquired via serial port

Code	Reference variable
13	Peak value, Input 1 maximum
14	Peak value, Input 1 minimum
15	Peak-to-peak value, Input 1
16	Peak value, Input 2 maximum
17	Peak value, Input 2 minimum
18	Peak-to-peak value, Input 2

Add-on function:

- +32 only for AL1 and AL2: relative limit In.3 and In.4 of digital input (diG.1,2 codes: 4, 5, 6).

- Press the [F] button briefly to confirm the reference variable.

You are now at the parameter $Rt.n$.



This parameter is used for entering the type of alarm limit.

- Use the code to specify the type of limit.

The types are classified as follows:

Code	Direct (overshoot) or inverse (undershoot)	Absolute or relative to current setpoint value	Normal limit or symmetric limit (window)
0	Direct	Absolute	Normal
1	Inverse	Absolute	Normal
2	Direct	Relative	Normal
3	Inverse	Relative	Normal
4	Inverse	Absolute	Symmetric
5	Direct	Absolute	Symmetric
6	Inverse	Relative	Symmetric
7	Direct	Relative	Symmetric

Note:

Limit 1 can only be absolute, because a relative limit must always relate to a previous absolute limit.

Add-on function

- Add the value for the add-on function onto the code for the type of alarm limit.
 - +8, disabled during power-up phase until first limit reached.
 - +16, enable limit buffer.
 - +32, change the color of the PV display when limit is active.
 - +64, the relative limit is referred to input IN3 (excludes code $Rr.n = 2$).
 - +128, the relative limit is referred to input IN4 (excludes code $Rr.n = 3$).
 - +256, change the color of the PV display when value exceeds limit (only for limits with delay).
 - +512, enable the assigned character string when limit is active.
 - +1024, enable the assigned character string when value exceeds limit (only for limits with delay).
- Confirm the limit type and any add-on function by pressing the [F] button briefly.

The display now shows the parameter $HY.n$.

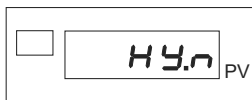

This parameter is used to set the hysteresis for the alarm limit (± 9999 scale divisions).

- Specify the hysteresis value and confirm it by pressing the [F] button briefly.

Next you must set the activation time for the respective limit. You do this in two steps.

First you come to the parameter $rA.n$, which is where you enter a value for the activation time.

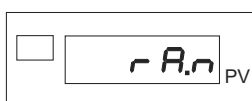

- Now specify the value for the activation time.
You can give the time in milliseconds, seconds or minutes.
- Confirm this value with the [F] button.
- In parameter $bE.n$, specify the units for the activation time.



Code	Units
0	Milliseconds
1	Seconds
2	Minutes

If, for parameter $AL.n$, you have enabled an add-on function that uses an assigned character string, you can now enter this string. Otherwise you skip the next steps and continue directly with configuring the next alarm limit or configuring the lower extreme value.

Note:

Before you can assign a character string to an alarm limit, you must enable the character set by adding the value "512" or "1024" to the code for the parameter $AL.n$ ("n" is the number of the limit between "1" and "4") in the menu ALL . If a different value has been added, the parameters for setting the character string are not displayed.

You can assign each enabled alarm limit a five-character alphanumeric string, which is displayed on the PV display (display level 1).

Each of the five characters is denoted by a specific upper-case letter:

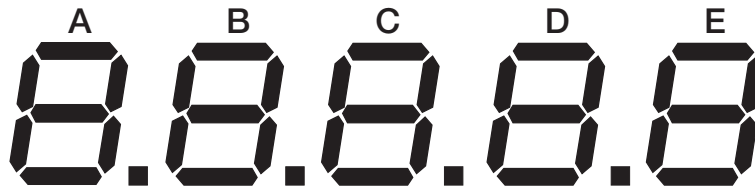

Figure 16: Letter notation used for the five characters in the display

This notation is also used for the parameters $SdA.n$, $Sdb.n$, $SdC.n$, $Sdd.n$ and $SdE.n$ in menu *ALL*.

You must give these parameters certain values according to which character string you want displayed for a limit.

These values are made up of the individual values of the display segments. The value of a character is simply the sum of the segment values

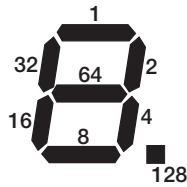

Figure 17: How the character value is generated.

Example:

In order to produce the character 3, you must set the relevant parameter to the value $1+2+4+8+64 = 79$.

The table below contains the values for the most commonly used characters.

You are now at the parameter $SdA.n$.

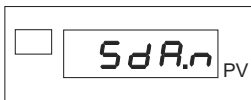

- Specify here the first character (character A) of the assigned character string.

Table 4: Values for the most commonly used characters

Character	Value
0	63
1	6
2	91
3	79
4	102
5	109
6	125
7	7
8	127
9	111
-	128

Character	Value
a	95
A	119
b	124
c	88
ç	57
d	94
E	123
É	121
F	113
Б	61
h	116
H	118

Character	Value
,	4
l	6
L	56
ï	55
n	84
o	92
0	63
P	115
r	80
S	109
t	120
U	62

- Press the [F] button briefly to confirm the character.

Specify characters B to E in the same way as for character A. The parameters *Sdb*, *Sdç*, *Sdd* and *SdÉ* are provided for this purpose.

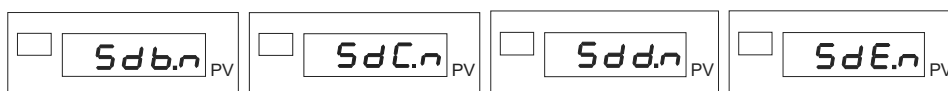

Once you have specified character E, you have completed the character-string assignment.

If you have enabled other alarm limits that you have not configured yet, you are then taken back to the parameter *Ar.n*, where you can configure these limits.

If you have now configured all the enabled alarm limits, you are taken to the parameter *Lo.AL*, which is where you specify the lower extreme value for the alarm limit.



- Set the lower extreme value.
This value must lie between -19 999 and 99 999.
- Press the [F] button briefly to confirm this value.
The display now shows the parameter *Hi.AL*.

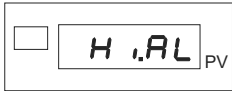

- Specify the upper extreme value here.

This value must also lie between -19 999 and 99 999.

- Press the [F] button briefly to confirm the value.

You have now reached the last step of the limit configuration process: parameter *rEL*.

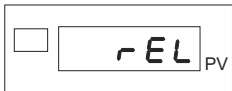

This parameter defines the behavior of the output if a sensor breaks (error code *Err*, *Sbr* and *Ebr*).

- Use a code to specify the behavior in the event of a broken sensor.

Code	Limit 1	Limit 2	Limit 3
0	OFF	OFF	OFF
1	ON	OFF	OFF
2	OFF	ON	OFF
3	ON	ON	OFF
4	OFF	OFF	ON
5	ON	OFF	ON
6	OFF	ON	ON
7	ON	ON	ON

Add-on function:

- +16, to set limit 4 to "ON"

- Press the [F] button briefly to confirm the input.

Configuration of the alarm limits is now complete and you are back in the main menu.

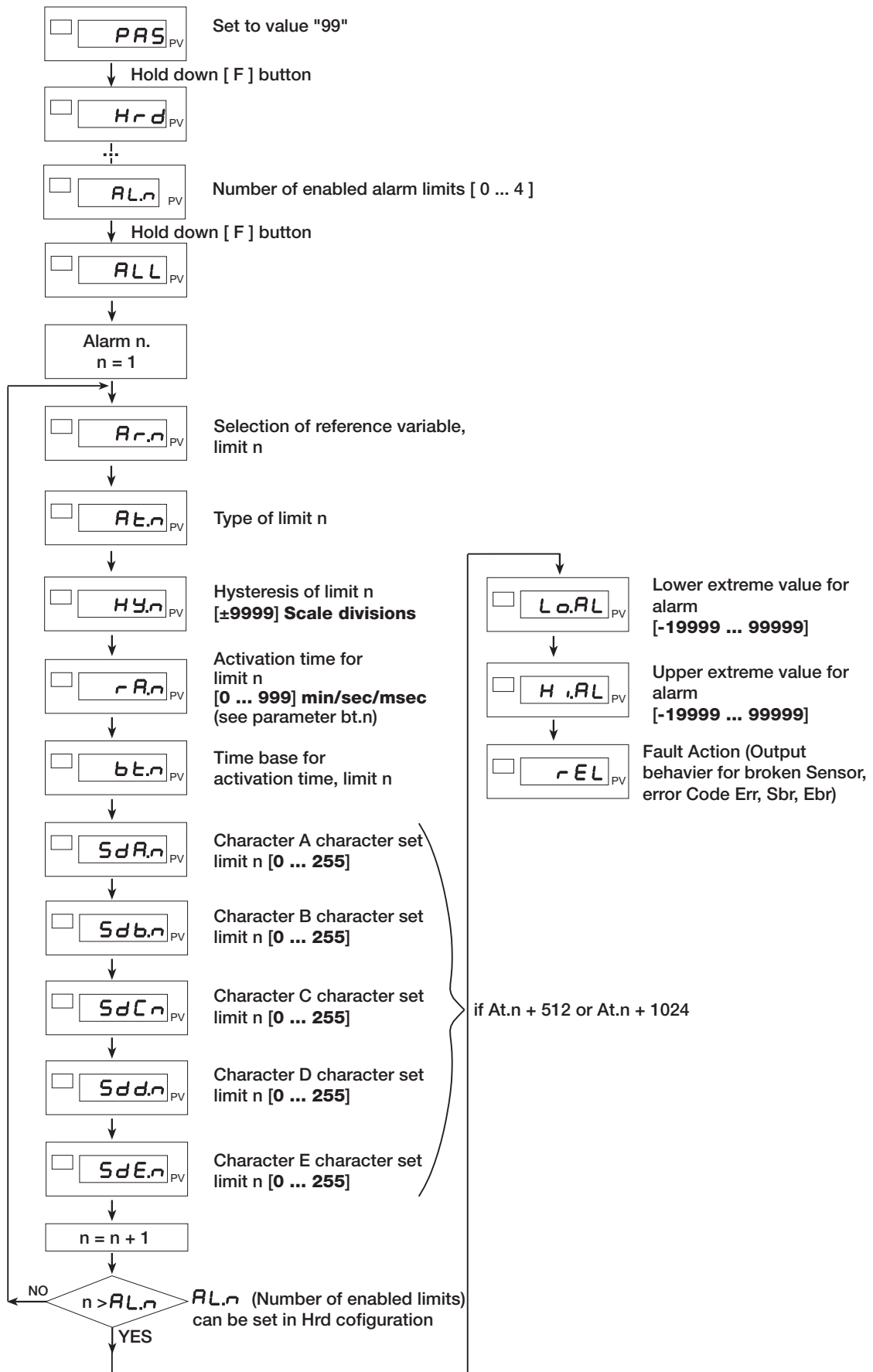
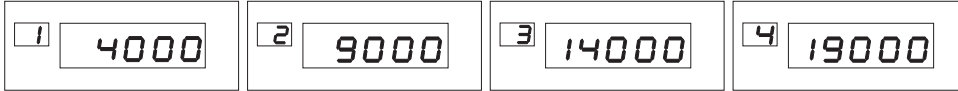

Figure 18: Procedure for configuring the alarm limits

10.4.3 Adjusting an alarm limit

- In measurement mode, press the [F] button briefly several times until the sub-display shows the number of the alarm limit that you wish to adjust.



- Press the ▲ or ▼ button.

This changes the setting for the limit concerned.

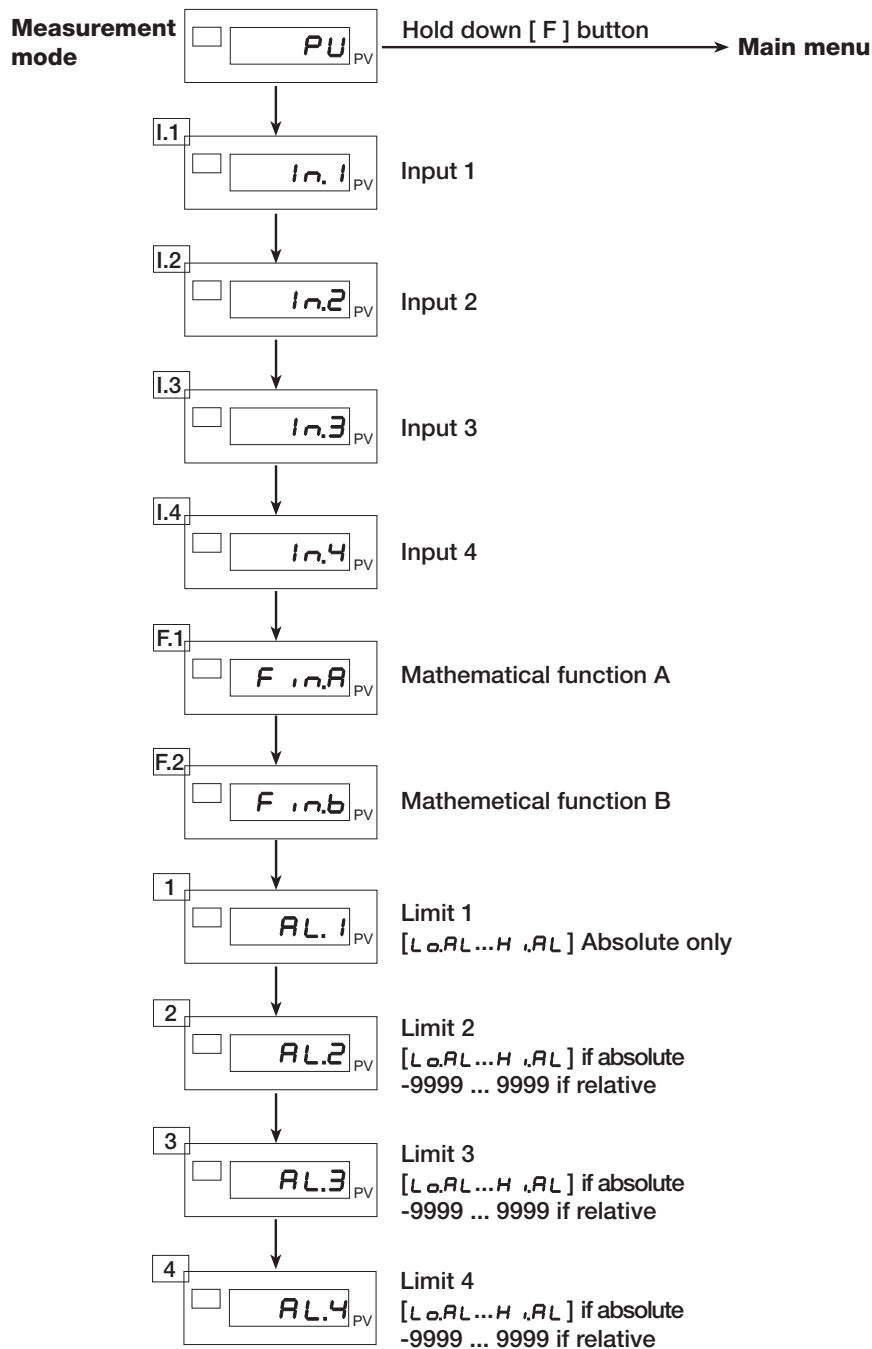

10.4.4 Selecting the contact type (NC / NO)



WARNING!

You will get an electric shock if the voltage is connected!

Disconnect the digital indicator from the power supply before opening the case.



CAUTION!

Risk of damage from electrostatic voltages!

Take suitable precautions when handling the boards.

The jumpers for selecting the contact type (normally closed “NC” / normally open “NO”) for the relay outputs are located on the soldering side of the power supply board.

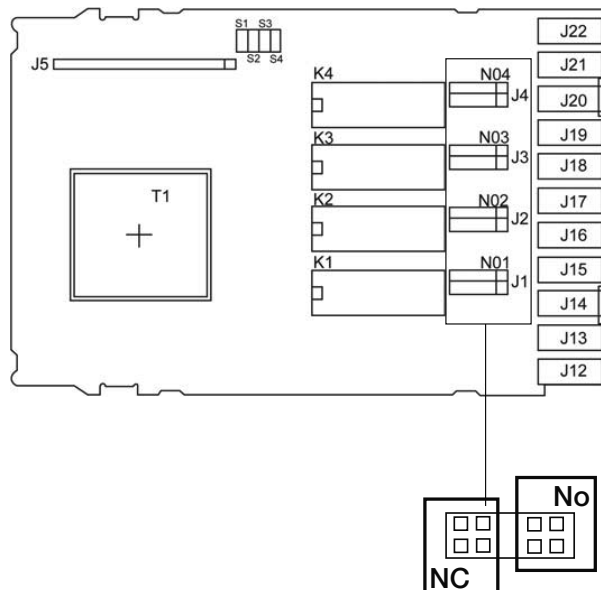

Note:

NO1-NO4 means contact type “NO” (factory setting)

NC1-NC4 means contact type “NC”

11. Interface configuration

11.1 Configuring the serial interface

The menu *SEr* is used for configuring a serial interface for data transfer.

- Switch from the main menu into the menu *SEr*.

To do this, hold down the [F] button until *SEr* is displayed.



- Press the [F] button once briefly.

The display now shows the parameter *Cod*.



This is used for setting the device address. A possible address must lie in the range "0" to "247".

- Set the required address.
- Press the [F] button briefly.

The display shows the parameter *bAu*.

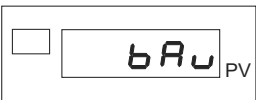

This is where you set the baud rate for data transmission.

The following baud rates are possible:

Code	Baud rate
0	1 200
1	2 400
2	4 800
3	9 600
4	19 200
5	38 400
6	57 600
7	115 200

- Press the [F] button.

The display now shows the parameter *PAR*.

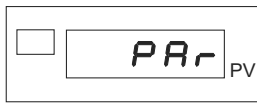

This parameter is used for setting the parity.

Code	Parity
0	none
1	odd
2	even

The serial interface is now configured.

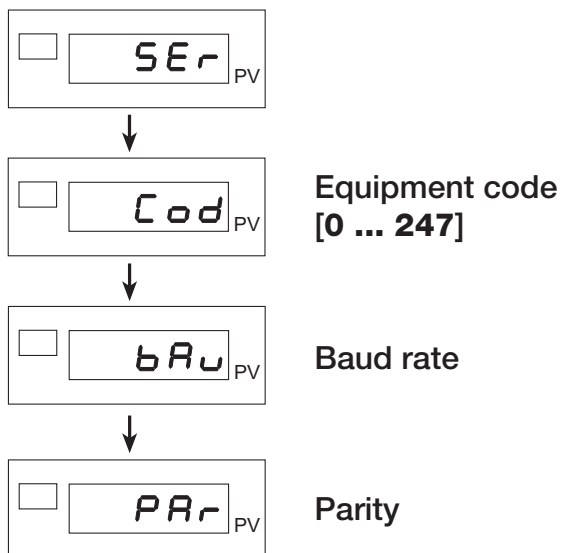

Figure 19: The menu *SER* is used for configuring a serial interface

11.2 Profibus interface (only for instruments with the Profibus option)

The separate Profibus manual contains information on the Profibus.



12. Hardware configuration

12.1 Accessing the protected area

The protected area contains:

- Mathematical functions
- Limit enable
- Button assignment
- Configuration of digital inputs
- Display settings
- Linearization of inputs
- Sensor-specific calibration

To gain access to the protected area:

- Go to the menu *PAS*.

To do this, in the main menu hold down the [F] button until *PAS* is displayed.

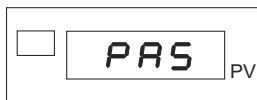

This menu contains just one parameter.

- Use the ▲ or ▼ buttons to set the value "99".

Once you have set the value, the protected area is unlocked. The protected area remains unlocked as long as you stay within it.

To access menus within the protected area, hold down the [F] button as usual.

12.2 Parameter lock



WARNING!

You will get an electric shock if the voltage is connected!

Disconnect the digital indicator from the power supply before opening the case.



CAUTION!

Risk of damage from electrostatic voltages!

Take suitable precautions when handling the boards.

The component side of the CPU card contains the jumper S9 which is used to control access to the menus of the instrument.

Enable access:

- Close jumper S9.

Disable access:

- Open jumper S9.

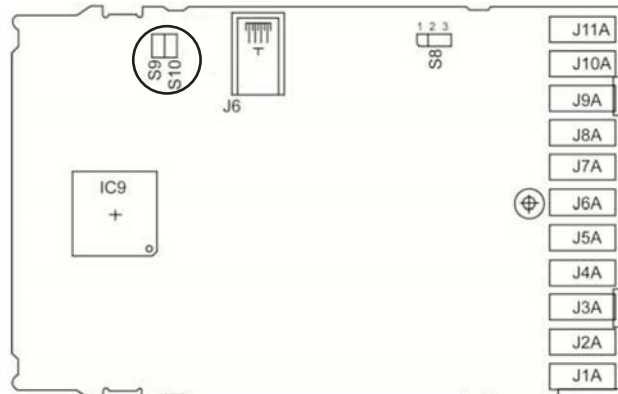

As you run through the menus (by holding down the [F] button), the menu **Out** is followed by the display **PR5**.

Access to the subsequent menus is only possible if you set the parameter **PR5** to the value "99".

You can use the parameter **Prd** to enable/disable the display and/or editing of specific parameters. These parameters include:

- *In1* to 4
- *Fin.A*
- *Fin.b*
- *RL.1* to 4

In addition, you can block access to these configuration menus:

- Main inputs (*I nP. 1, I nP.2*)
- Auxiliary inputs (*I nP.3, I nP.4*)
- Alarm limits (*ALL*)
- Outputs (*Out*)
- Serial interface (*SEr*)
- *CF6*

In addition, you can inhibit the software power-down (instrument stand-by) and disable the tare function.

- First go to the menu *PAS*.

To do this, hold down the [F] button until *PAS* is displayed.

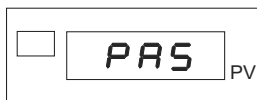

- Use the ▲ or ▼ buttons to set the value "99".
- Hold down the [F] button until *Pro* is displayed.



- Set the Pro parameter to one of these values:

Code	Display and edit these parameters
0	<i>I n 1, I n 2, I n 3, I n 4</i> <i>F in.A, F in.B</i> <i>AL. 1, AL. 2, AL. 3, AL. 4</i>
1	<i>I n 1, I n 2, I n 3, I n 4</i> <i>F in.A, F in.B</i> <i>ALL, Out</i>
3	<i>F in.A, F in.B</i>

Add-on functions

- +4 to block access to the menus *I nP. 1, I nP.2, I nP.3, I nP.4, ALL* and *Out*
- +8 to block access to the menu *SEr* and the interface configuration
- +16 to inhibit the software power-down (instrument stand-by)
- +32 to disable the tare memory function

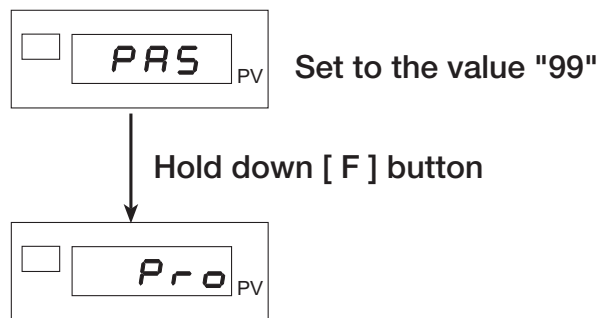

Figure 20: Access to the menu *PrO* is password protected

12.3 Instrument settings

12.3.1 Mathematical functions

- First go to the menu *PAS*.

To do this, hold down the [F] button until *PAS* is displayed.

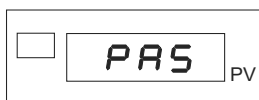

- Use the ▲ or ▼ buttons to set the value "99".
- Hold down the [F] button until *Hrd* is displayed.

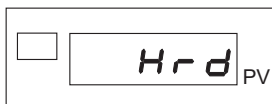

- Press the [F] button briefly several times until *Func.A* is displayed.



This parameter is used to select the mathematical function that you can apply to the input values of the digital indicator.

Code	Function
0	Function disabled
1	$\text{Fin.A} = \frac{(\text{C1.A} * \text{In1.A})^{\text{C2.A}} \text{OPeR} (\text{C3.A} * \text{In2.A})^{\text{C4.A}}}{\text{C5.A}}$
2	IN1 + IN2
3	IN1 – IN2
4	IN1 / IN2 (IN2 can only take positive values in the range 1 to 99 999)
5	$\sqrt{\text{IN 1}}$ (IN1 can only take positive values in the range 0 to 99 999)
6	(IN1 + IN2)/2
7	IN3 x C1.A
8	(IN1 + IN2 + IN3 + IN4) / 4

If you select function 0, 2, 3, 4, 5, 6 or 8, you skip the following steps and you are taken directly to the parameter for selecting the second mathematical function *Func.b*.

If you select function 7, you must specify the coefficient *[I.A]* (range –9.99 to 99.99). Once you have entered this value, you are taken directly to the parameter for selecting the second mathematical function *Func.b*.

If you select function 1, you need to specify further parameters before getting to the second mathematical function *Func.b.*

If you select function 1:

- Specify the values for the two variables *In 1.A* and *In 2.A*.

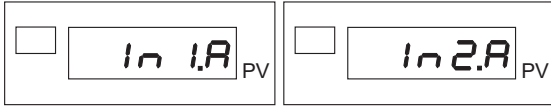

The following settings are possible:

Code	Variable
0	= 0
1	IN1
2	IN2

Code	Variable
3	IN3
4	IN4
6	Fin.B

- Press the [F] button briefly to confirm each value.
- The display now shows the parameter *OPER.A*.



- You now need to specify the mathematical operator A.

The following settings are possible:

Code	Operator
0	+
1	-

Code	Operator
2	x
3	/

- Confirm with the [F] button.
- Specify the coefficient *C 1.A*.

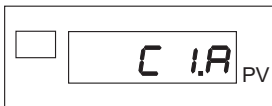

This coefficient must lie in the range -9.99 to 99.99.

- Specify the next coefficient $C2.A$.

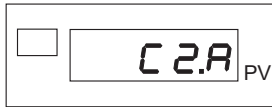

The following settings are possible:

Code	Value
0	1
1	1/2
2	2

- Now specify the coefficient $C3.A$.

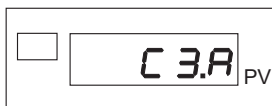

This coefficient must lie in the range -9.99 to 99.99.

- Specify the coefficient $C4.A$.

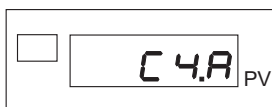

The following settings are possible:

Code	Value
0	1
1	1/2
2	2

- Finally, specify the coefficient $C5.A$.

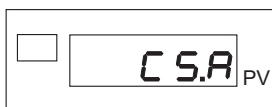

This coefficient must lie in the range -9.99 to 99.99.

Once you have specified the coefficient $C5.A$, you have finished configuring the parameters for mathematical function A.

Example: simple differential measurement

This differential measurement shall be applied to the inputs IN3 and IN4.

We set the parameters for the mathematical function A as follows:

$$\begin{aligned}
 \text{Func.A} &= \text{Fin.A} = \frac{(\text{C1.A} * \text{In1.A})^{\text{C2.A}} \text{OPeR} (\text{C3.A} * \text{In2.A})^{\text{C4.A}}}{\text{C5.A}} \\
 \text{In1.A} &= \text{IN3} \\
 \text{In2.A} &= \text{IN4} \\
 \text{OPeR.A} &= - \\
 \text{C1.A} &= 1 \\
 \text{C2.A} &= 1 \\
 \text{C3.A} &= 1 \\
 \text{C4.A} &= 1 \\
 \text{C5.A} &= 1
 \end{aligned}$$

If we substitute the parameters *In1.A* to *C5.A* in the selected formula, one obtains the formula:

$$\text{Func.A} = \frac{(1 \times \text{IN3})^1 - (1 \times \text{IN4})^1}{1}$$

Which gives:

$$\text{Func.A} = \text{IN3} - \text{IN4}$$

You are now at parameter *Func.b*.



This parameter is used to select the mathematical function that you can apply to the input values of the digital indicator.

Code	Function
0	Function disabled
1	$\text{Fin.b} = \frac{(\text{C1.b} * \text{In1.b})^{\text{C2.b}} \text{OPERb} (\text{C3.b} * \text{In2.b})^{\text{C4.b}}}{\text{C5.b}}$
2	IN1 + IN2
3	IN1 – IN2
4	IN1 / IN2 (IN2 can only take positive values in the range 1 to 99 999)
5	$\sqrt{\text{IN 1}}$ (IN1 can only take positive values in the range 0 to 99 999)
6	(IN1 + IN2)/2
7	IN3 x C1.b
8	(IN1 + IN2 + IN3 + IN4) / 4

If you select function 0, 2, 3, 4, 5, 6 or 8, skip the following steps and you are taken directly to the parameter for enabling the alarm limits (see section 10.4.1 "Enabling alarm limits").

If you select function 7, you must specify the coefficient $C1.b$ (range –9.99 to 99.99). Once you have entered this value, you are taken directly to the parameter for enabling the alarm limits.

If you select function 1, you need to specify further parameters before getting to the parameter for enabling the alarm limits.

If you select function 1:

- Specify the values for the two variables $in1.b$ and $in2.b$.

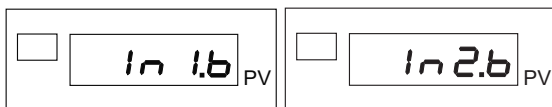

The following settings are possible:

Code	Variable
0	= 0
1	IN1
2	IN2

Code	Variable
3	IN3
4	IN4
6	Fin.A

- Press the [F] button briefly to confirm each value.
- The display now shows the parameter $OPER.b$.



- You now need to specify the mathematical operator B.

The following settings are possible:

Code	Operator
0	+
1	-

Code	Operator
2	x
3	/

- Confirm with the [F] button.
- Specify the coefficient [1.b].

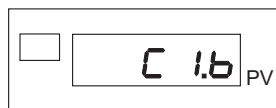

This coefficient must lie in the range -9.99 to 99.99.

- Specify the next coefficient [2.b].

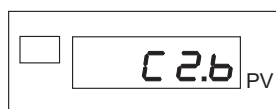

The following settings are possible:

Code	Value
0	1
1	1/2
2	2

- Now specify the coefficient [3.b].

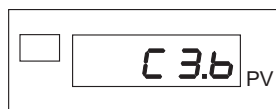

This coefficient must lie in the range -9.99 to 99.99.

- Specify the coefficient [4.b].

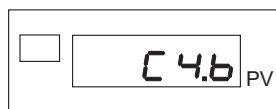

The following settings are possible:

Code	Value
0	1
1	1/2
2	2

- Finally, specify the coefficient *C5.b*.

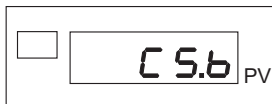

This coefficient must lie in the range -9.99 to 99.99.

Once you have specified the coefficient *C5.b*, you have finished configuring the parameters for mathematical function B. You are now at parameter *AL.n*. This is used for enabling alarm limits.

Page 108 contains an example of a mathematical function.

12.3.2 Button assignment

- First go to the menu *PAS*.

To do this, hold down the [F] button until *PAS* is displayed.



- Use the ▲ or ▼ buttons to set the value "99".
- Hold down the [F] button until *Hrd* is displayed.

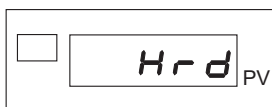

- Press the [F] button briefly several times until *but. 1* is displayed.



Factory default:

but. 1 stands for the [PEAK] button.

but. 2 stands for the [CAL / RST] button.

but. 3 stands for the [★] button.

You have the following assignment options for all three buttons:

Code	Function
0	Locked (no function)
2	HOLD IN1
3	Clear limit buffer
7	Set / Reset = OUT1 to 4 (only for <i>but. I</i>)
8	Enable peak value + (maximum IN1)
9	Enable peak value - (minimum IN1)
10	Enable peak-to-peak value (max. peak value – min. peak value) IN1
11	Clear peak-value buffer IN1
12	Clear limit buffer / peak-value buffer IN1
15	Strain gauge calibration check IN1 (using shunt resistor)

Code	Function
16	Strain gauge calibration IN1
23	Zero display (tare) IN1
24	Zero display (tare) IN1 / Clear limit buffer
25	Zero display (tare) IN1 / Clear peak-value buffer IN1
26	Zero display (tare) IN1 / Clear limit buffer / Clear peak-value buffer IN1
27	Display HOLD
28	FLASH IN1
29	Net /Gross (when Gross value being shown the units digit flashes on the display.

Add-on functions

- +32 when referring to IN2 (only for table values that refer to IN1).
- +64, only possible for *but. 3*, disables the function "button [F] + [★]" ("back menu").

"HOLD" function

The input value and the limit status values are "frozen" during the period the digital input is active.

When an input is active, then resetting the limit buffer results in all energized relays being released and the buffer for all limits being cleared.

"FLASH" function

The input value is read and the limits are "frozen"; if the logic input goes active, the input value is "frozen" and the limits are updated based on the last value detected.

When you have confirmed the function you are taken to the parameter *d 5.1*. This parameter is used with the subsequent parameter *d 5.2* to define the function of the two digital inputs.

12.3.3 Digital inputs

- First go to the menu *PAS*.

To do this, hold down the [F] button until *PAS* is displayed.

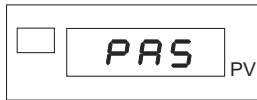

- Use the ▲ or ▼ buttons to set the value "99".
- Hold down the [F] button until *Hrd* is displayed.

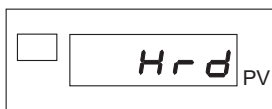

- Press the [F] button briefly.
- You are now at the parameter *Hd. I*.

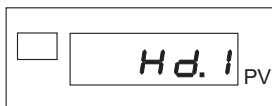

This is used for setting the process type and mains frequency.

The "Fast" setting is used e.g. for pressure and flow-rate control functions, whereas "Slow" is used e.g. for temperature regulation functions.

You have the following selection options:

Code	Process type
0	Fast (mains frequency 50 Hz)
2	Slow (mains frequency 50 Hz)

Code	Process type
4	Fast (mains frequency 60 Hz)
6	Slow (mains frequency 60 Hz)

Add-on function:

- +8 sets the digital inputs DI1 and DI2 to "NPN" operation.
- Press the [F] button briefly.
- You are now at the parameter *d i6. I*.

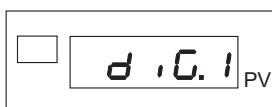

This parameter is used with the subsequent parameter *d i6.2* to define the function of the two digital inputs.

- Specify the functions of the two digital inputs.

You have the following options:

Code	Function
0	Locked (no function)
2	HOLD IN1
3	Clear limit buffer
4	Limit threshold 1 of input IN.3
5	Limit threshold 2 of input IN.4
6	Limit threshold 1 of input IN.3 and limit threshold 2 of input IN.4
7	Set / Reset = OUT1 to 4
8	Enable peak value + (maximum IN1)
9	Enable peak value - (minimum IN1)
10	Enable peak-to-peak value (max. peak value – min. peak value) IN1
11	Clear peak-value buffer IN1
12	Clear limit buffer / peak-value buffer IN1
15	Strain gauge calibration check IN1 (using shunt resistor)

Code	Function
16	Strain gauge calibration IN1
17	Software shut-down of device
18	Disable the [F] button
19	Remote operation of [F] button
20	Remote operation of ▲ button
21	Remote operation of ▼ button
23	Zero display (tare) IN1
24	Zero display (tare) IN1 / Clear limit buffer
25	Zero display (tare) IN1 / Clear peak-value buffer IN1
26	Zero display (tare) IN1 / Clear limit buffer / Clear peak-value buffer IN1
27	Display HOLD IN1
28	FLASH IN1
29	Net / Gross (when enabled = gross)
30	Change color of PV display.

Add-on functions

- +32 when referring to IN2 (only for table values that refer to IN1).
 - +64 for an input with inverted logic.
 - +128 to force logic state "1" (on).
- Confirm with the [F] button.

The display now shows the parameter *d5.5P*, which is used for configuring the display.

12.3.4 Display settings

- First go to the menu *PA5*.

To do this, hold down the [F] button until *PA5* is displayed.

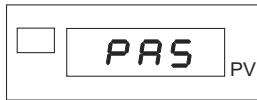

- Use the ▲ or ▼ buttons to set the value "99".
- Hold down the [F] button until *Hrd* is displayed.

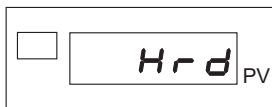

- Press the [F] button briefly several times until *d5.5P* is displayed.

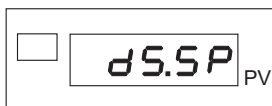

- Specify here the variable that the display will show in normal mode.

You have the following options:

Code	Function
1	IN1
2	IN2
3	IN3
4	IN4
8	Analog output

Code	Function
9	Fin.A
10	Fin.B
32	alternating IN1, IN2 (approx. 1.2 s)
64	alternating IN1, IN2, IN3 (approx. 1.2 s)
128	alternating IN1, IN2, IN3, IN4 (approx. 1.2 s)

Add-on function:

- +16 for a green process-value display.
 - + 512 avoids the automatic switching of the display
- Press the [F] button briefly to confirm your selection.
 - Then specify the physical variable to be displayed in the F display.

d5.F specifies the physical variable for the F display in the PV display.

d5.PU specifies the physical variable for IN1 to be displayed in the F display.

5d5.5P specifies the physical variable for IN2 to be displayed in the F display.

5d5.F specifies the physical variable for IN3 to be displayed in the F display.

5d5.PU specifies the physical variable for IN4 to be displayed in the F display.

You have the following options for all parameters:

Code	Variable	Code	Variable
0		10	nA
1	°C	11	A
2	°F	12	_.n
3	rH	13	_.S
4	PA	14	Li
5	PH	15	%
6	bA	16	i.1
7	_.h	17	i.2
8	nU	18	i.3
9	U	19	i.4

Once you have confirmed the physical variable for IN4, the display shows the parameter *LEd. 1*.

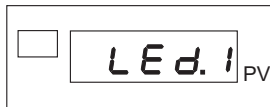

- Use this parameter and the subsequent parameters (*LEd.2*, *3* and *4*) to set the function of the LEDs L1-L4.

You have the following options for all four parameters:

Code	Function
0	no function
3	HOLD IN1
4	HOLD IN2
7	Replicate DI1
8	Replicate DI2
9	Fault (broken sensor)
13	AL1
14	AL2
15	AL3
16	AL1 or AL2
17	AL1 or AL2 or AL3

Code	Function
18	AL1 and AL2
19	AL1 and AL2 and AL3
20	Check on automatic calibration IN1
21	Check on automatic calibration IN2
22	Display peak value + (maximum IN1)
23	Display peak value - (minimum IN1)
24	Display peak-to-peak value IN1
25	Display peak value + (maximum IN2)
26	Display peak value - (minimum IN2)
27	Display peak-to-peak value IN2

Add-on function:

- +32 enables flashing of the LED when the display is active.
- +64 to invert the state of the LED.

Once you have specified the functions of the LEDs you have completed the hardware configuration process. When you have confirmed the function you are taken back to the main menu.

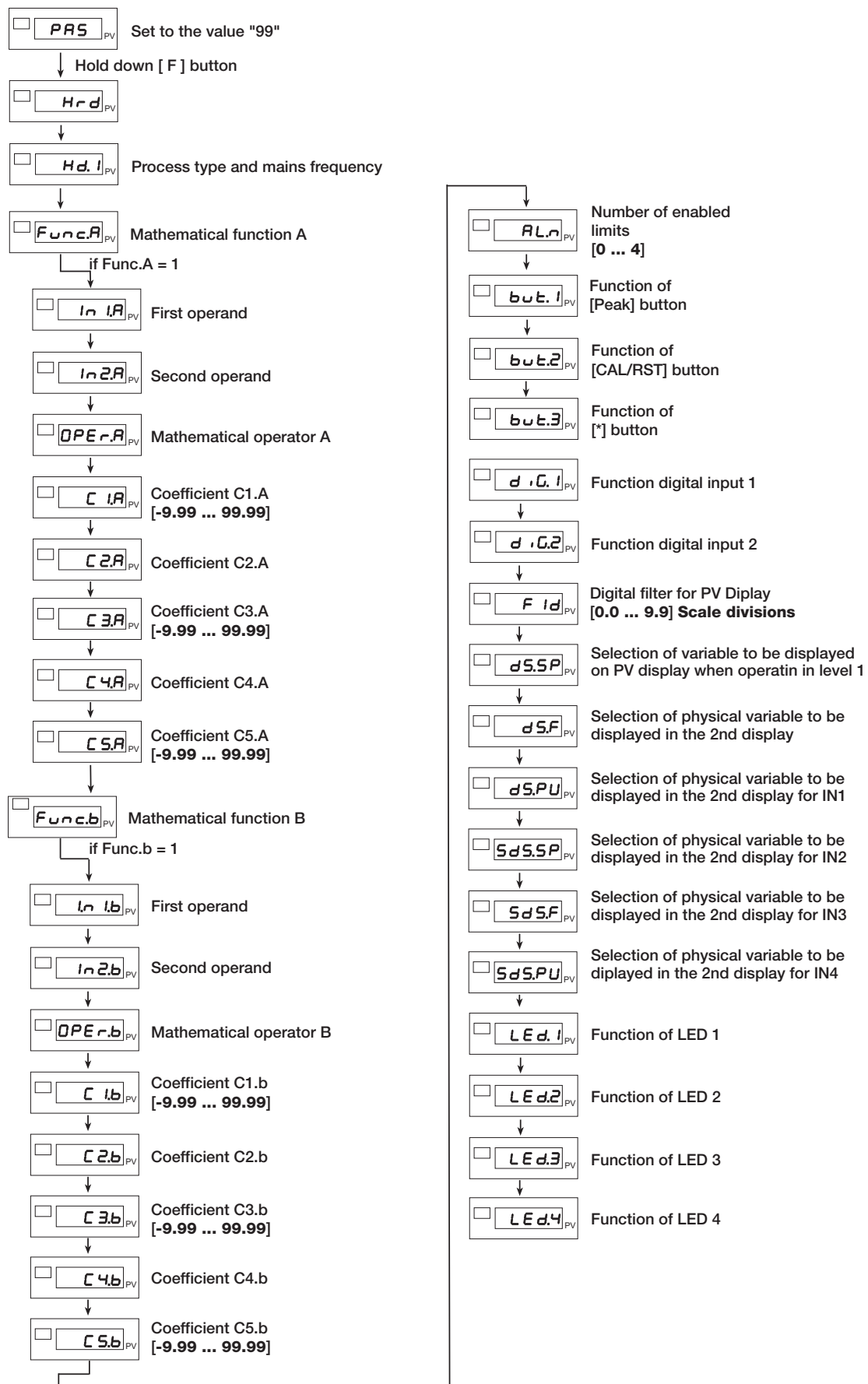

Figure 21: The instrument settings are made in the menu *Hrd*.

13. Sensor-specific calibration

The calibration procedure depends on the sensor that was specified for the selected input.

General information

The type 9163 digital indicator can be calibrated (scaled) by a choice of methods.

- Calibration using a physical variable
- Calibration by entering data from the sensor test certificate

The following sections describe in greater detail the various calibration and adjustment options.

13.1 Potentiometer or linear signals

Calibration is necessary in order to define the relationship between the electrical signals measured by the connected sensors and the measured values to be displayed. This is a two-point calibration. Normally the sensors have a test and calibration certificate which you can use to find the values of the electrical signals.

A certificate may look like the example shown below, where the most important values are highlighted.



Figure 22: Test and calibration certificate for a potentiometric position sensor

Measurements using a calibrated gauge block have proved to be the most straightforward and practical way of calibrating systems that measure position and length (such as potentiometric position sensors). Potentiometric angle sensors can also be connected.

Perform the following steps to carry out a calibration:

Note:

Before a calibration, connect all the sensors to the digital indicator. If all the sensors that are connected to the digital indicator during normal operation are not connected, measurement errors can arise in the calibration.

Note:

If necessary, you can abort the calibration procedure from the parameter **C.L.O** onwards. To abort the process, hold down the **[*]** + **[F]** buttons simultaneously. You are then taken back to the parameter **U.CAL**.

Note:

Potentiometric position sensors usually have electrical dead regions at the beginning and end of the measurement range, where the measurement signal does not change despite movement of the sliding shaft.

- Connect the sensors to the instrument.
- First go to the menu **PAS**.

To do this, hold down the **[F]** button until **PAS** is displayed.



- Use the **▲** or **▼** buttons to set the value "99".
- Hold down the **[F]** button until **U.CAL** is displayed.



- Select the relevant input:

Code	Function
1	Input IN1
2	Input IN2
3	Input IN3
4	Input IN4

- Press the **[F]** button briefly to confirm your selection.

You are now at the parameter **C.L.O**.

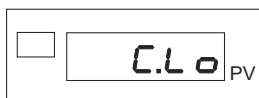

- Set the potentiometer to the minimum value.

This means that the potentiometer slider must sit in the position for the minimum voltage.

If the input value is symmetrical, the slider must sit in the center position.

- Press the [F] button briefly to confirm the minimum value.

The display now shows the parameter **C.H i**.

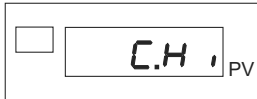

- Set the potentiometer to the maximum value.

The potentiometer slider must sit in the position for the maximum voltage.

- Press the [F] button briefly to confirm the maximum value.

This completes calibration of a potentiometer or a linear signal.

You are now back in the main menu at the top of the menu **U.CAL**.

13.2 Strain Gauge Sensors and Strain Gauge Simulators

Note:

If you are using a calibrator for calibration, set the parameter *ALS* in the menu *OUT* to "0". Otherwise the digital indicator signals an error *Ebr*.

The calibration procedure below is used to define the relationship between the electrical measurement signal from the connected strain gauge sensor (-lower calibration value, upper calibration value) and the measurement that is to be displayed (lower scale value, upper scale value). It is a simple two-point calibration procedure.

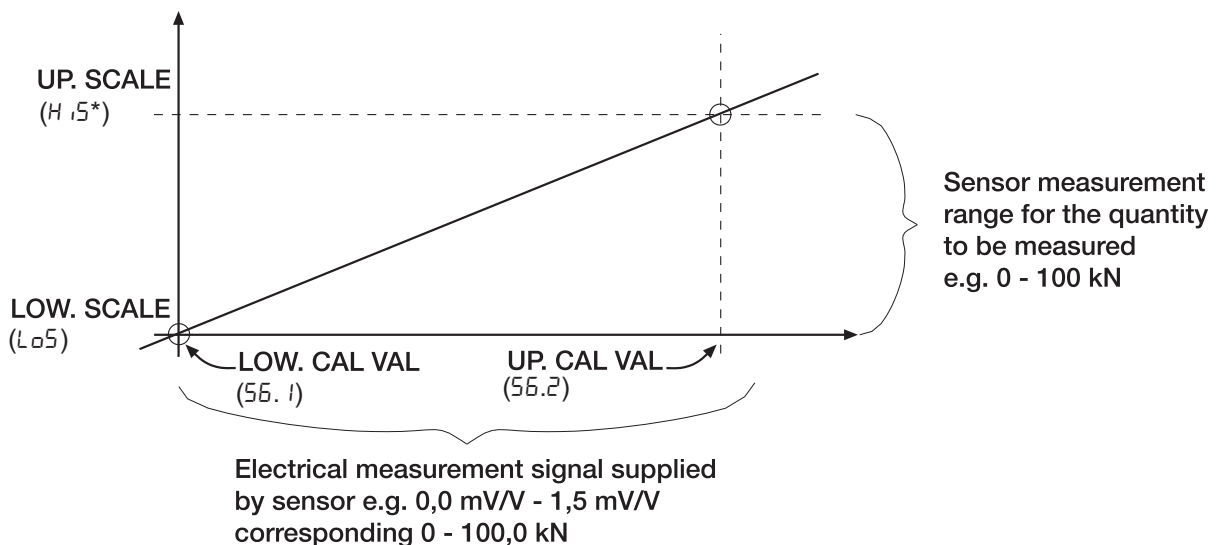

Figure 23: Measured quantity and sensor signal

*You are able to change the magnitude *H15* during calibration.

The values are related as follows:

Lower scale value	↔	Lower calibration value
Upper scale value	↔	Upper calibration value

The lower calibration value is the electrical signal from the sensor when the "load" given by the lower scale value is applied (usually the zero point of the sensor).

Since the zero point of a strain gauge tends to shift from the origin as a result of the way the gauge is mounted (components used to transfer the force exert an initial load themselves) or material ageing, the electrical value specified under "zero point" in the sensor test certificate rarely tallies with the value actually measured. So always perform the teach-in for this value.

Other terms:

Rated load	→	Upper scale value
Zero signal	→	Zero point, zero signal without assembly parts, lower calibration value
Rated output	→	Output signal at rated load, sensitivity in preferential measurement direction, upper calibration value

Type of connection: 4-wire technology

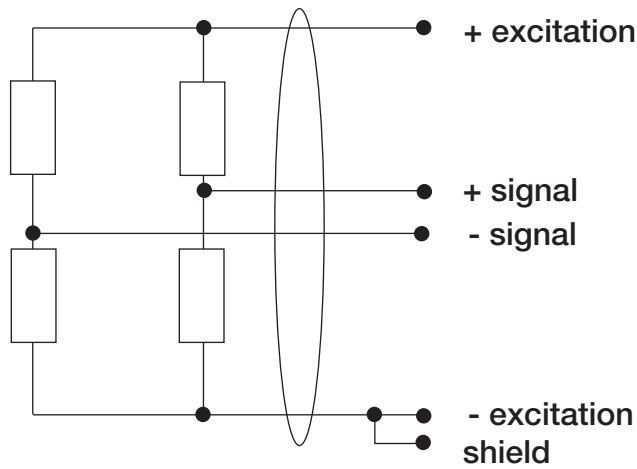

Figure 24: 4-wire technology

A measuring chain contains a number of components, each contributing to the overall measurement accuracy of the test setup. One can avoid these accuracy problems by using the standard solution of the 6-wire circuit, or by calibrating as a unit the 4-wire circuit as the complete measuring chain.

In most applications, however, the 4-wire connection is quite adequate.

Note:

The type 9163 digital indicator only supports 4-wire technology.

Perform the following steps to carry out an adjustment using a Sensor:

Note:

Before an adjustment, connect all the sensors to the digital indicator. If not all the sensors that are connected to the digital indicator during normal operation are connected, measurement errors can arise in the adjustment.

It is also possible to connect a Strain Gauge Simulator model 9405, which can simulate the output signal of a strain gauge simulator. This will give you the ability to make an adjustment of the indicator with a sensor of a measurement range that can not be covered by a reference. For more information about adjustments using a Strain Gauge Simulator refer to page 125.

Note:

If necessary, you can abort the indicator adjustment procedure from the parameter **56.1** onwards. To abort the process, hold down the [*****] + [F] buttons simultaneously. You are then taken back to the parameter **U.CAL**.

- Connect the sensor to the instrument.
- Remove any load from the sensor.
- First go to the menu **PAS**.

To do this, hold down the [F] button until **PAS** is displayed.

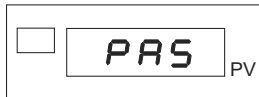

- Use the ▲ or ▼ buttons to set the value "99".
- Hold down the [F] button until **U.CAL** is displayed.



- Select the relevant input:

Code	Function
1	Input IN1
2	Input IN2
3	Input IN3
4	Input IN4

- Press the [F] button briefly to confirm your selection.

You are now at the parameter **56.1** (refer to Figure 26: on 137).

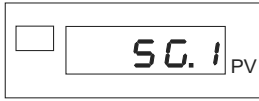

This parameter is used for recording the zero output when the sensor is not under load.

- Press the [F] button briefly.

If you have specified a strain gauge sensor for this channel and the input range 40 mV (sensor class 28 or 29, see section 9.1: "Configuring a main input" on page 69) you get directly back to **U.CAL**.

If you have specified a strain gauge sensor with a sensitivity of 1.5 to 4 mV/V for this channel (sensor class 14 or 15, see section 9.1: "Configuring a main input" on page 69) the display starts to flash.

- In this case, wait a few seconds.

The display jumps to the parameter **56.2**.



This parameter is used to define the output signal and nominal value (e.g. the nominal force) of the sensor.

Prüf- und Kalibrierprotokoll Test- and Calibration Certificate			
Zug- Druck- Kraftsensor Tension-Compression load cell	/ Type	:	8435-5200
Typ	/ Serial no.	:	338479
Serien-Nr.	/ Quality Inspections		
Qualitätsprüfungen	/ Nominal Force	F_{nom}	: 0 ... 200 N
Nennkraft	/ Accuracy (Combined value)	f_{comb}	: $\leq \pm 0,35$ % v.E. / FS
Fehlergrenzen (Zusammengesetzter Fehler) Summe der Fehler aus Linearitätsabweichung, Relative Umkehrspanne und Reproduzierbarkeit	/ Combined value for nonlinearity, / repeatability and hysteresis.		
Kalibriert in	/ Calibration for		: Druckrichtung / compression
Maximale Gebrauchskraft	/ Maximum Force, Operating	F_G	: 150 % v.E. / FS
Referenzspeisespannung	/ Reference Excitation	U_{ref}	: 5,0 V
Ausgangssignal (Kennwert)	/ Output signal (Sensitivity)	C	: 1,0480 mV/V
Ausgangssignal beim Messbereichsendwert bei tariertem Nullpunkt	/ Output signal at measuring range / with balanced zero.		
Nullsignal ohne Einbauteile	/ Zero Output / without fitting parts	S_0	: 0,0169 mV/V
Eingangswiderstand	/ Input Impedance	R_e	: 378,65 Ω
Ausgangswiderstand	/ Output Impedance	R_b	: 353,04 Ω
Isolationswiderstand	/ Insulation Resistance	R_{is}	: ≥ 10 M Ω @ 45 V
Kalibriersprung (bei unbelastetem Aufnehmer)	/ Shunt Cal Factor (without any load)	C_{shunt}	: 0,8828 mV/V
Kalibrierwiderstand	/ Calibration Resistor (Shunt)	R_{shunt}	: 100 k Ω
Ein Kalibrierwiderstand R_{shunt} zwischen -Speisung und -Ausgangssignal, erzeugt bei tariertem Nullpunkt, den angegebenen Kalibriersprung C_{shunt}	/ A Calibration Resistor R_{shunt} connected / across -excitation and -output produce / this Shunt Cal Factor C_{shunt} / with balanced Zero Output.		
Validiert nach Prüfanweisung	/ Validated according to Inspection Instruction		: 1206



- Now load the sensor with the reference weight or reference pressure (typical is the end of range value, e.g. pressure or load).
- Use the ▲ and ▼ buttons to adjust the displayed reference value.
- Press the [F] button briefly.

The display starts to flash again.

- Wait a few seconds.

You are now at the parameter **56.3**.

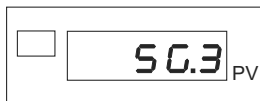

This parameter is used for the final calculation of the zero point.

- Remove any load from the sensor.
- Press the [F] button briefly.

That completes the calibration of the strain gauge sensor.

You are now back in the main menu at the top of the menu **U.CAL**, where you can perform further calibrations.

Perform the following steps to carry out an adjustment using a Strain Gauge Simulator model 9405:

Connecting a Strain Gauge Simulator model 9405 gives you the ability to make an adjustment of the indicator with a sensor of a measurement range that can not be covered by a reference value.

Note:

If necessary, you can abort the indicator adjustment procedure from the parameter **56.1** onwards. To abort the process, hold down the [★] + [F] buttons simultaneously. You are then taken back to the parameter **U.CAL**.

- Connect the Strain Gauge Simulator to the instrument.
- Set the Strain Gauge Simulator to 0 mV/V.

It is also possible to use the zero signal of the particular sensor. Doing this, you have to connect this Sensor to the indicator without any load.

- First go to the menu *PAS*.

To do this, hold down the [F] button until *PAS* is displayed.



- Use the ▲ or ▼ buttons to set the value "99".
- Hold down the [F] button until *U.CAL* is displayed.



- Select the relevant input:

Code	Function
1	Input IN1
2	Input IN2
3	Input IN3
4	Input IN4

- Press the [F] button briefly to confirm your selection.

You are now at the parameter *SG. I* (refer to Figure 26: on 137).

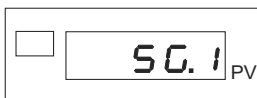

This parameter is used for recording the preset zero value of the connected Strain Gauge Simulator.

- Press the [F] button briefly.

If you have specified a strain gauge sensor for this channel and the input range 40 mV (sensor class 28 or 29, see section 9.1: "Configuring a main input" on page 69) you get directly back to *U.CAL*.

If you have specified a strain gauge sensor with a sensitivity of 1.5 to 4 mV/V for this channel (sensor class 14 or 15, see section 9.1: "Configuring a main input" on page 69) the display starts to flash.

- In this case, wait a few seconds.

The display jumps to the parameter **56.2**.

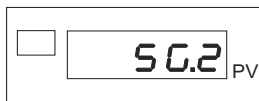

This parameter is used to define the output signal and nominal value (e.g. the nominal force) of the sensor.

Prüf- und Kalibrierprotokoll Test- and Calibration Certificate		burster	
			
Zug- Druck- Kraftsensor Tension-Compression load cell			
Typ	/ Type	:	8435-5200
Serien-Nr.	/ Serial no.	:	338479
Qualitätsprüfungen	/ Quality Inspections		
Nennkraft	/ Nominal Force	F _{nom}	: 0 ... 200 N
Fehlergrenzen (Zusammengesetzter Fehler) Summe der Fehler aus Linearitätsabweichung, Relative Umkehrspanne und Reproduzierbarkeit	/ Accuracy (Combined value) / Combined value for nonlinearity, / repeatability and hysteresis.	f _{comb}	: ≤ ± 0,35 % v.E. / FS
Kalibriert in	/ Calibration for		: Druckrichtung / compression
Maximale Gebrauchskraft	/ Maximum Force, Operating	F _G	: 150 % v.E. / FS
Referenzspeisespannung	/ Reference Excitation	U _{ref}	: 5,0 V
Ausgangssignal (Kennwert) Ausgangssignal beim Messbereichsendwert bei tarierterem Nullpunkt	/ Output signal (Sensitivity) / Output signal at measuring range with balanced zero.	C	: 1,0480 mV/V
Nullsignal ohne Einbauteile	/ Zero Output / without fitting parts	S ₀	: 0,0169 mV/V
Eingangswiderstand	/ Input Impedance	R _e	: 378,65 Ω
Ausgangswiderstand	/ Output Impedance	R _a	: 353,04 Ω
Isolationswiderstand	/ Insulation Resistance	R _i	: ≥ 10 MΩ @ 45 V
Kalibriersprung (bei unbelastetem Aufnehmer)	/ Shunt Cal Factor (without any load)	C _{Shunt}	: 0,8828 mV/V
Kalibrierwiderstand Ein Kalibrierwiderstand R _{Shunt} zwischen Speisung und Ausgangssignal, erzeugt bei tarierterem Nullpunkt, den angegebenen Kalibriersprung C _{Shunt} .	/ Calibration Resistor (Shunt) / A Calibration Resistor R _{Shunt} connected / across excitation and output produce / this Shunt Cal Factor C _{Shunt} / with balanced Zero Output.	R _{Shunt}	: 100 kΩ
Validiert nach Prüfanweisung	/ Validated according to Inspection Instruction		: 1206

If you have used the sensor for recording the zero signal, connect the Strain Gauge Simulator now.

- Now set the Strain Gauge Simulator to the next lower sensitivity, seen from the sensor's sensitivity.

If your sensor has a sensitivity of e.g. 1.0480 mV/V, stated in the report, you have to set the Strain Gauge Simulator to 1.0 mV/V.

- Calculate the reference value using the formula:

$$\frac{\text{simulator setting} \times \text{nominal value of the sensor}}{\text{output signal (sensitivity) of the sensor}} = \text{reference value}$$

Example: Calculation of the reference value, if you use a Strain Gauge Simulator

Nominal value: 200 N

Sensitivity of the sensor: 1.0480 mV/V

Simulator setting: 1 mV/V

$$\frac{1 \text{ mV/V} \times 200 \text{ N}}{1.0480 \text{ mV/V}} = \text{example reference value}$$

- Use the ▲ and ▼ buttons to adjust the displayed value of reference weight or pressure.

- Press the [F] button briefly.

The display starts to flash again.

- Wait a few seconds.

You are now at the parameter **56.3**.



This parameter is used for the final calculation of the zero point.

- Set the Strain Gauge Simulator to 0 mV/V.

If you have used the sensor for recording the zero signal, you now have to connect the sensor again, without any load.

- Press the [F] button briefly.

That completes calibration of the strain gauge sensor.

You are now back in the main menu at the top of the menu **U.CAL**, where you can perform further calibrations.

13.3 RTD (PT100)

This passive sensor is made of platinum. The nominal resistance at a temperature of 0 °C equals 100 Ω. The mean temperature change between 0 °C and 100 °C equals 0.385 % / °C. The temperature values and the corresponding resistance values are specified in DIN EN 60751.

The sensors are classed A or B. A Class A sensor can deviate by 0.35 °C at 100 °C, and a Class B sensor by 0.8 °C.

The temperature is measured by measuring the resistance of the Pt100 resistance thermometer, which is then converted by the instrument into °C.

Perform the following steps to carry out a calibration:

Note:

Before a calibration, connect all the sensors to the digital indicator. If all the sensors that are connected to the digital indicator during normal operation are not connected, measurement errors can arise in the calibration.

Note:

If necessary, you can abort the fine adjustment procedure for the analog output from the parameter *rtd.Lo* onwards. To abort the process, hold down the [★] + [F] buttons simultaneously. You are then taken back to the parameter *U.CAL*.

- Connect the sensors to the instrument.
- First go to the menu *PAS*.

To do this, hold down the [F] button until *PAS* is displayed.

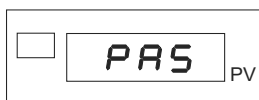

- Use the ▲ or ▼ buttons to set the value "99".
- Hold down the [F] button until *U.CAL* is displayed.



- Select the relevant input:

Code	Function
1	Input IN1
2	Input IN2

- Press the [F] button briefly to confirm your selection.

You are now at the parameter *rtd.Lo*.

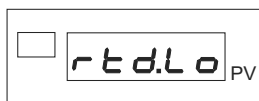

This parameter is used for the minimum resistance of the RTD. For a Pt100 this equals 18.52 Ω ; it cannot be changed.

- Press the [F] button briefly.

You are now at the parameter *rtd.H i*.

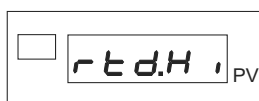

This parameter is used for the maximum resistance of the RTD. For a Pt100 this equals 390.48 Ω ; it cannot be changed.

- Press the [F] button briefly.

That completes calibration of the RTD sensor.

You are now back in the main menu at the top of the menu *U.CAL*, where you can perform further calibrations.

13.4 Thermocouple (TC)

These active sensors are made of two wires of different metals or metal alloys fused together at one end.

When the fused junction is heated, a thermal EMF is produced at the wire ends. The amplitude of the EMF depends on the type of metals used and the temperature difference between the measuring point and the reference junction.

Materials used nowadays comply with the set of fundamental values given in DIN EN 60584 and DIN 43710.

Perform the following steps to carry out a calibration:

Note:

Before a calibration, connect all the sensors to the digital indicator. If all the sensors that are connected to the digital indicator during normal operation are not connected, measurement errors can arise in the calibration.

Note:

If necessary, you can abort the fine adjustment procedure for the analog output from the parameter **tc.00** onwards. To abort the process, hold down the [**★**] + [F] buttons simultaneously. You are then taken back to the parameter **U.CAL**.

- Connect the sensors to the instrument.
- First go to the menu **PAS**.

To do this, hold down the [F] button until **PAS** is displayed.

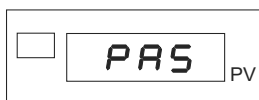

- Use the ▲ or ▼ buttons to set the value "99".

Hold down the [F] button until **U.CAL** is displayed.



- Select the relevant input:

Code	Function
1	Input IN1
2	Input IN2

- Press the [F] button briefly to confirm your selection.

The display now shows the parameter *t_c.00*.



This parameter is used by the digital indicator for calibration at 0 mV.

- Press the [F] button briefly.

You are now at the parameter *t_c.50*.

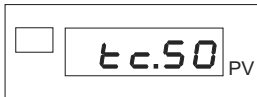

This parameter is used by the digital indicator for calibration at 50 mV.

- Press the [F] button briefly.

The next parameter is the parameter *t_c.t_A*.



- Enter the ambient temperature of the instrument in °C.
- Press the [F] button briefly.

That completes calibration of the thermocouple (TC).

You are now back in the main menu at the top of the menu *U.CAL*, where you can perform further calibrations.

13.5 Input linearization

The menu *L_{in}* is used for input linearization.

- First go to the menu *PAS*.

To do this, hold down the [F] button until *PAS* is displayed.



- Use the ▲ or ▼ buttons to set the value "99".
- Hold down the [F] button until *L_{in}* is displayed.

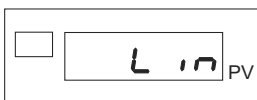

- Press the [F] button briefly once.

You are now at the parameter **L_YP.L**, which is used to input the linearization type.

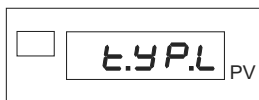

You can select from the following linearization types:

Code	Linearization type
0	Variable intervals (maximum 32 intervals)
1	Variable intervals with teach-in of IN1 (maximum 32 intervals (= steps))
2	Variable intervals with teach-in of IN2 (maximum 32 intervals (= steps))
3	Variable intervals with teach-in of IN3 (maximum 32 intervals (= steps))
4	Variable intervals with teach-in of IN4 (maximum 32 intervals (= steps))
5	Linearization with fixed intervals (64 intervals (= steps))

- Press the [F] button briefly to confirm the linearization type.

The linearization process for an input is identical up to this point for all linearization types.

From point "**S_tEP.n**" onwards, however, the procedure for linearization types 0 to 4 differs from that for linearization type 5.

You have selected one of the linearization types 0 to 4:

Once you have selected the linearization type or scale for the temperature sensor, you reach the parameter **S_tEP.n**.



- Set the number of intervals (steps) you require.

You must set a value of at least one and no more than 32.

Once you have confirmed the number by pressing the [F] button briefly, you access the parameter **5.00**.



- Set the lower scale value.

Enter here the same value that you have set for this input in the parameter **L₀5**. This value must lie between -19 999 and 99 999.

After confirming ([F] button), the display shows the parameter **5.0 IR**.

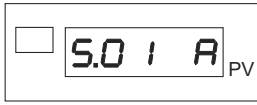

If linearization involves "teach-in", the input is measured. You need to confirm this value by pressing the [F] button.

- Set here the assigned / measured input value in multiples of 1/10 000 of the value that you will specify in the parameter **5.0 Ib**.

The value of the parameter **5.0 Ib** must lie between 0 and 10 000.

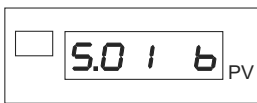

Repeat these steps for the number of intervals that you have specified in the parameter **STEP.n**.

You have selected linearization type 5:

Once you have selected the linearization type or scale for the temperature sensor, you reach the parameter **5.00**.

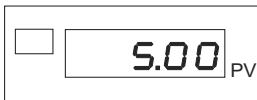

- Set the lower scale value.

Enter here the same value that you have set for this input in the parameter **L05**. This value must lie between -19 999 and 99 999.

- Confirm this value ([F] button).
- Enter the values for the intervals 1 to 64.

Use the following equation to calculate these values:

$$\text{Value} = \frac{(\text{mV lower scale limit} + n \cdot (\text{mV upper scale limit} - \text{mV lower scale limit}))}{64}$$

"n" = number denoting the interval (1-64).

The value for the equation must lie between -19 999 and 99 999 for each value of "n".

Note:

The value **5.54** must equal the value that you have set for this input in the parameter **H i5**.

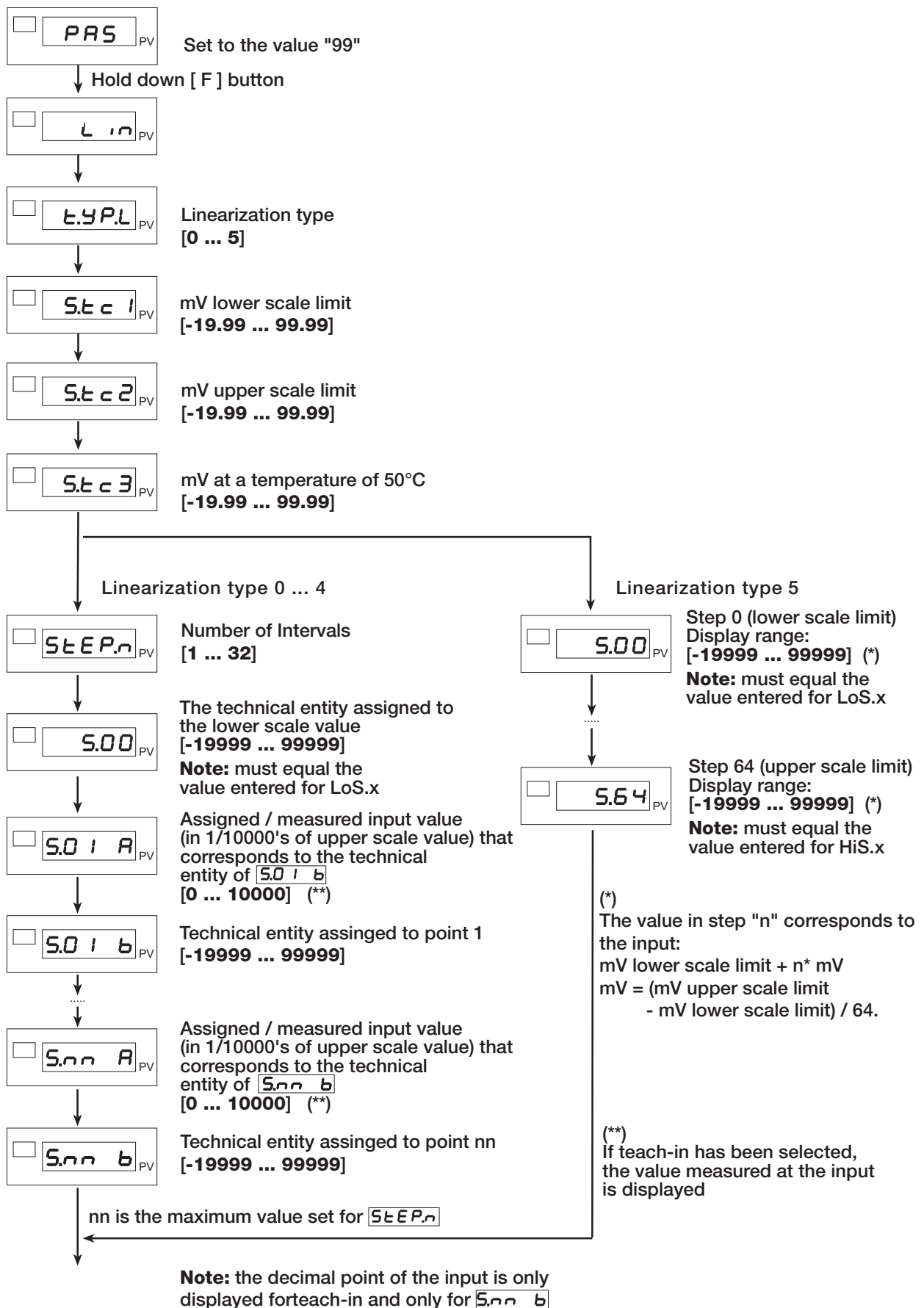

Figure 25: Input linearization

13.6 Restoring factory-set calibration

- First go to the menu *PAS*.

To do this, hold down the [F] button until *PAS* is displayed.



- Use the ▲ or ▼ buttons to set the value "99".
- Hold down the [F] button until *U.CAL* is displayed.



- Add 32 to the code of the input whose calibration you wish to reset (+32).

This produces the following codes for restoring the factory-set calibration:

Code	Function
0	-
33	Input IN1
34	Input IN2
35	Input IN3
36	Input IN4
39	<i>CA.r.t</i> - Fine adjustment of the analog output

- Press the [F] button briefly.

You have then reset the calibration of the input concerned to the factory setting.

You are now back in the main menu at the top of the menu *U.CAL*, where you can perform further calibrations.

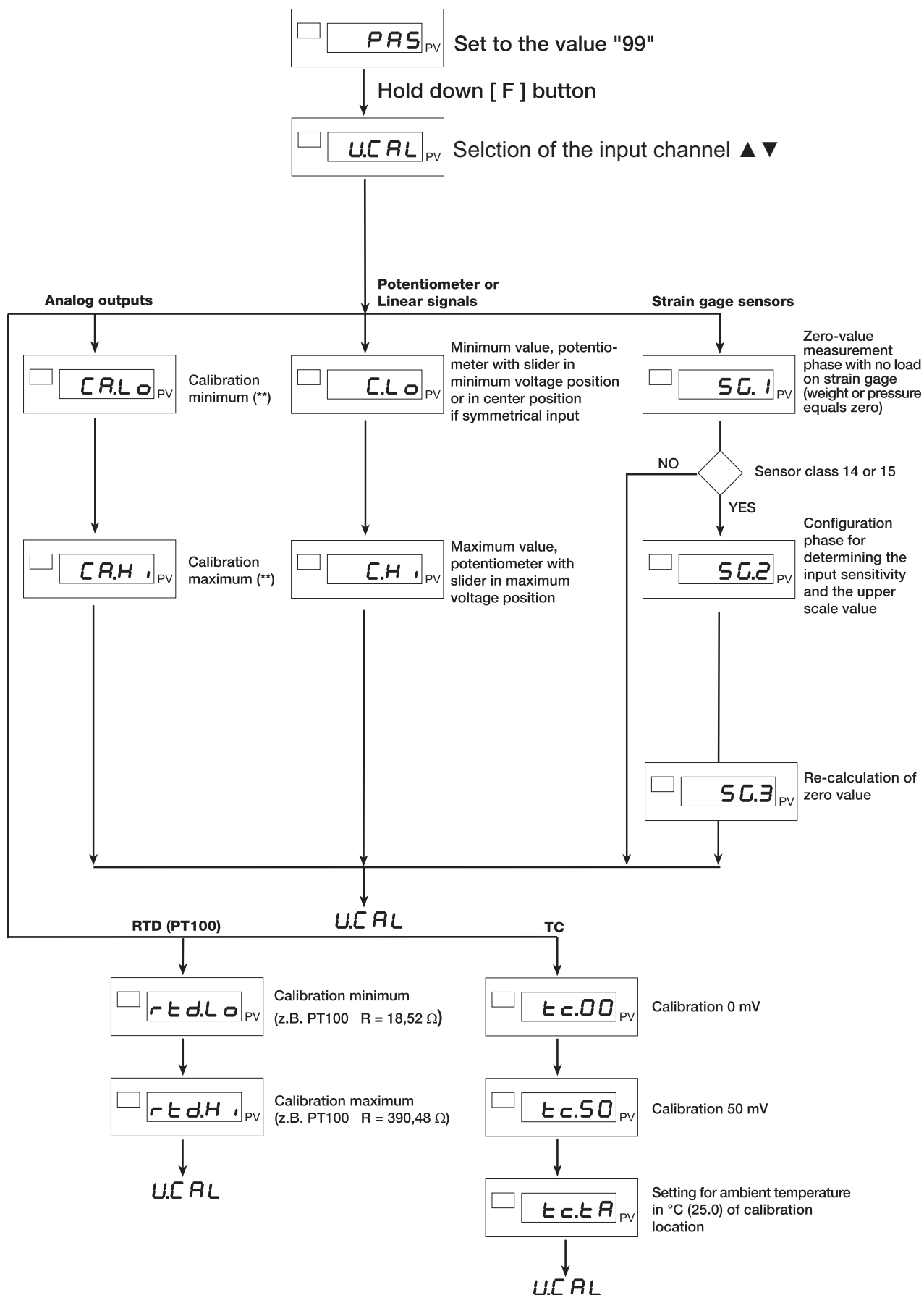

Figure 26: Calibration of different sensor types



14. Instrument power-up / power-down via software (stand-by)

The factory default is for the ON / OFF function to be enabled.

This function can be assigned to a digital input.

14.1 Switch-off (power-down / stand-by)

- Press and hold the [F] and ▲ buttons simultaneously for longer than 5 seconds.

The 9163 now puts itself in the OFF state.

During this stand-by mode, the mains supply is maintained and the lower (PV) display is deactivated, with the display "OFF" remaining on.

All outputs (limit outputs and relay outputs) assume the OFF state (logic outputs to "0", relays released).

All instrument functions, with the exception of actual-value acquisition and display and the power-up function, are deactivated.

14.2 Switch-on (power-up)

- Press and hold the [F] button for longer than 5 seconds.

The 9163 now switches from the OFF state into the ON state.

Disabling the ON / OFF function entirely

If you have fully disabled the ON / OFF function, you cannot put the instrument into stand-by mode.

- Add 16 to the value of the parameters Pr_{\square} (see section 12.2: "Parameter lock" on page 102) ($Pr_{\square} + 16$).

If the power supply is disconnected when the instrument is in stand-mode, the 9163 returns to the "OFF" state when the power supply is restored.



15. Maintenance



WARNING!

You will get an electric shock if the voltage is connected.

Disconnect the digital indicator from the power supply before opening the case.

If the instrument is installed in accordance with the instructions and recommendations of this operating manual, and configured correctly, it will work properly. Apart from normal cleaning of the front panel and internal components where necessary, no other special maintenance operations are required.

Before opening the case, always make sure that the power supply is disconnected from the instrument.

To access the internal components (e.g. for cleaning or checking the jumpers), you simply need to unscrew the fixing screws on the front panel and pull out the unit. There is no need to disconnect cables.

The instrument has no On-Off switch.

15.1 Cleaning



CAUTION!

The front panel of the digital indicator will be damaged.

Never use hydrocarbon-based cleaning solvents (e.g. benzene etc.)

Use a cloth moistened with water or alcohol to clean the front panel and the case.

Do not use compressed air to remove dust from the printed circuit boards: use a clean paint brush with soft hairs.

15.2 Repair

Repairs must only be carried out by technical personnel authorized by burster.

If unauthorized persons make repairs or modifications to the hardware, the warranty is immediately void.

The component side of the CPU card contains the jumper S9 which, if inserted, enables access to the menus of the instrument.

15.3 Troubleshooting

Table 5: Symptoms and their cause

Symptom	Cause and remedial action
The display and the LEDs on the instrument do not switch on	The power supply to the instrument is the problem. Check whether the supply voltage lies across terminals 10 and 11. Make sure that the supply voltage matches the specification in the order code: 9163-V0xxxx: 100 to 240 V AC/DC 9163-V1xxxx: 20 to 27 V AC/DC
The characters shown on the display are incomplete or illegible	One or more segments of the display may be faulty. Switch the unit off and back on again, and check whether all the segments are working. During power-up, a self-diagnosis test is performed in which all the segments flash (displays the value BBBBB). If one or more segments are not flashing, contact burster Customer Services.
When I hold down the [F] button, the configuration menu is not displayed.	If the problem occurs at the first installation, it is probably because the instrument's hardware configuration is not set to accept any changes to the preset parameters, apart from changes to the setpoint value and the limits in display level 1. (The jumper S9 on the CPU card enables access to the parameters for editing).
When I press the [F] button and hold it down, I cannot access all the parameters or configuration menus	Access to some menus and/or parameters is protected by a password PAS and a protection code Prd . Section 12: "Hardware configuration" on page 101 explains how to enter the password and protection code.
Instead of showing the actual value, the PV display shows one of the following messages: LD - HI - Sbr - Err - Ebr Ebr.Lo - Err.td	In the first four cases, an error has been detected in the input signal (see section 3 for details). Err : For a Pt100 sensor: The input is short-circuited. If the thermocouple has a short-circuit, the PV display shows the (entered) ambient temperature of the instrument instead of the actual value. For a 4 to 20mA input signal: The transmitter is faulty or has no excitation. Ebr : the strain gauge sensor is faulty or has no excitation. Ebr.Lo : no voltage for sensor excitation. Err.td : third wire of Pt100 sensor broken or not connected.

16. Technical specifications

Only those values, functions and ranges are guaranteed whose accuracy is specified within relative or absolute tolerances or within specified limits.

Table 6: Technical specifications of the digital indicator

Display	1 x 5 digit, two-color red/green, character height 13 mm 1 x 2 digit, red, character height 7 mm 14 x red LEDs
Buttons	6 mechanical buttons (Peak, CAL/RST, *, UP, DOWN, F)
Accuracy	0.1 % of upper scale value ± 1 scale division at an ambient temperature of 25 °C
Temperature drift	< 150 ppm/°C of upper scale value for respective inputs / voltage and strain gauge
Main input/main inputs IN1, IN2	Strain gauge sensors: 350 Ω , sensitivity 1.5...4 mV/V, with sensor excitation 5/10 V DC $\pm 5\%$ Potentiometer: $\geq 100 \Omega$, $R_i > 10 \text{ M}\Omega$ at 2.5 V DC DC linear: $\pm 60\text{mV}$, $\pm 100\text{mV}$, $\pm 1\text{V}$, $\pm 5\text{V}$, $\pm 10\text{V}$, $R_i > 10\text{M}\Omega$ 0/4...20 mA, $R_i = 50 \Omega$ TC, RTD Sampling interval: 2 msec
Type TC (thermocouple) (ITS90)	J, K, R, S, T (IEC 584-1, CEI EN 60584-1,60584-2) Custom linearization possible (64 linearization steps)
Compensation error	0.1° / °C
Type RTD (resistance thermometer) (ITS90)	Pt100 (DIN43760),
Max. wire resistance for RTD	20 Ω
Type PTC / Type NTC	990 Ω , 25°C / 1 k Ω , 25 °C
Reliability	Short-circuit and broken-sensor detection, Monitoring of sensor excitation, LBA limit
Auxiliary inputs IN3, IN4	Potentiometer: 1...10 k Ω , at 10 Vdc DC linear signals: 10 V, $R_i > 2 \text{ M}\Omega$ 0/4...20 mA, $R_i = 50 \Omega$ Sampling interval: 10 msec
Linear scale values	-19 999...99 999, configurable decimal point
Limit outputs with relay OUT 1, OUT 2, OUT 3, OUT 4	NO (NC) 5A, 250 V / 30 V DC
Limit outputs with transistor OUT 1, OUT 2, OUT 3, OUT 4	24 Vdc, > 18 V at 20 mA $R_u = 390 \Omega$

Digital inputs DI1, DI2	Insulation voltage 1500 V, Sampling interval 60 ms, 24 V DC, 5 mA (PNP) or from isolated contact (NPN) max. 5 mA. PNP/NPN selected using configuration parameter
Type of analog output OUT W	Analog, resolution better than 0.03 %, Insulation voltage 1500 V, refresh rate 2 ms, synchronous with scanning of IN1 and IN2 values 0/2...10 V, ± 10 V max. 25 mA, short-circuit protected 0/4...20 mA, max. load 500 Ω
Upper adjustment limit	-100.0 ... 100.0 %
Stand-by function:	The actual value display remains enabled
Configurable limits	Up to 4 limits can be assigned to one output, and configured as follows: maximum value, minimum value, symmetrical values, absolute/relative values, LBA for AL1, AL2, calculated every 2 ms, synchronous with scanning of IN1 and IN2 values; for AL3, AL4, calculation every 2...4 ms depending on the number of limits
Special functions for limits	Disable option in power-up phase, limit buffer, reset via keyboard and/or contact
Sensor excitation	5 V DC, 10 V DC for strain gauge sensors, max. 200 mA 1, 2 V DC for potentiometer $\geq 100 \Omega$
Transmitter excitation	24 V DC ± 5 %, max. 200 mA
Serial interface	RS232, RS485 insulation voltage 1500 V
Baud rate	1200, 2400, 4800, 9600, 19200, 38400, 57600, 115200 bit/s
Protocol	MODBUS RTU
Power supply (variable-voltage switch mode power supply)	(standard) 100...240 V AC/DC ± 10 % (optional) 20...27 V AC/DC ± 10 % 50/60 Hz, max. 20 VA Protected by internal fuse; cannot be accessed by user
Front panel degree of protection	IP54
Operating/storage temperature	0...50 °C/-20...70 °C
Relative humidity	20...85 % non-condensing
Operating environment	For use in enclosed rooms, altitude up to 2000 m
Installation	Removable from the front when installed in instrument panel
Installation regulations	Installation Category II, Degree of pollution 2, Class II insulation
Weight	450 g

17. Order codes, accessories and options

Process value indicator model 9163-V

Standard: 0 0 0 0 0

Options:

Case and auxiliary		
Panel-mount unit 100 - 240 V AC	_____	0
Panel-mount unit 20 - 27 V AC/V DC	_____	1
Bench-top unit 100 - 240 V AC	_____	3
Analog output voltage		
none	_____	0
0 - 10 V	_____	1
0 - 20 mA	_____	2
4 - 20 mA	_____	3
± 10 V	_____	4
Interface		
none	_____	0
RS232	_____	1
RS485	_____	2
Profibus ¹⁾	_____	3
USB ²⁾	_____	4
Limit output		
4 x relay	_____	0
4 x transistor (open e. p-switching)	_____	1
Version		
1 main channel	_____	0
4 main channel up to 2 x DMS resp. 4 x Process	_____	1

¹⁾ no analog output and no bench-top unit possible

²⁾ possible only at bench-top unit

Adapter cables and software are listed on the next page

Accessories for Sensormaster 9163-V3xxxx

Adapter cable from sensor socket 1 or 2 to strain gauge sensors with 5 V DC or 10 V DC excitation voltage with fitted plug 9900-V209 and to potentiometric position sensors with 5 V DC excitation voltage with fitted plug 9900-V209.

Order code

Type 99209-609A-0090002

Adapter cable from sensor socket 1 or 2 to transmitter with 15 V DC or 24V DC excitation voltage and sensors with fitted plug 9900-V209.

Type 99209-609B-0090002

Adapter cable from sensor socket 3/4 to transmitter with 10 V DC excitation voltage or potentiometric position sensors with 5V DC excitation voltage and fitted plug 9900-V209 and sensor connecting cable with 99209-XXXX....

Type 99208-609B-0090002

Adapter cable from sensor socket 3/4 to transmitter with 15 V DC or 24V DC excitation voltage and fitted plug 9900-V209.

Type 99208-609A-0090002

Software

Convenient DigiVision configuration and analysis software for the 9163 equipment range

Type 9163-P100

18. Appendix

18.1 Menu options

Table 7: Level 1

Display	Default value	CONF	MOD bus	Description
<i>PU / SU / F</i>	-		PV LSW: 530 PV MSW: 531	
<i>I n.1</i>			LSW: 536 MSW: 537	Main input IN1
<i>I n.2</i>			LSW: 538 MSW: 539	Main input IN2
<i>I n.3</i>			LSW: 540 MSW: 541	Auxiliary input IN3
<i>I n.4</i>			LSW: 542 MSW: 543	Auxiliary input IN4
<i>F in.A</i>			LSW: 544 MSW: 545	Result of mathematical function A
<i>F in.b</i>			LSW: 546 MSW: 547	Result of mathematical function b
<i>AL.1</i>	4 000		LSW: 554 MSW: 555	Limit 1
<i>AL.2</i>	9 000		LSW: 556 MSW: 557	Limit 2
<i>AL.3</i>	14 000		LSW: 558 MSW: 559	Limit 3
<i>AL.4</i>	19 000		LSW: 560 MSW: 561	Limit 4

Table 8: Menu *I nF*

Display	Default value	CONF	MOD bus	Description
<i>UPd</i>	1.33 and above		581	Software version
<i>Cod</i>	1		693	Equipment code
<i>Err.1</i>	0		582	Error code for IN1
<i>Err.2</i>	0		583	Error code for IN2
<i>Err.3</i>	0		584	Error code for IN3
<i>Err.4</i>	0		585	Error code for IN4
<i>Err.5</i>	-		1333	Error code for <i>F in.A</i>
<i>Err.6</i>	-		1334	Error code for <i>F in.b</i>

Display	Default value	CONF	MOD bus	Description
dP5.5	-		1335	Position of decimal point <i>F in.A</i>
dP5.6	-		1336	Position of decimal point <i>F in.B</i>
Lo5.5	-		LSW: 1337 MSW: 1338	Lower scale value <i>F in.A</i> (read only)
Lo5.6	-		LSW: 1339 MSW: 1340	Lower scale value <i>F in.B</i> (read only)
Hi5.5	-		LSW: 1341 MSW: 1342	Upper scale value <i>F in.A</i> (read only)
Hi5.6	-		LSW: 1343 MSW: 1344	Upper scale value <i>F in.B</i> (read only)

Table 9: Menu 5Er

Display	Default value	CONF	MOD bus	Description
cod	1		693	Equipment code
baud	4		694	Serial communications baud rate
PAR	0		695	Serial communications parity

Table 10: Menu Input 1

Display	Default value	CONF	MOD bus	Description
Typ. 1	15		696	Sensor or signal type for input IN1
FLt. 1	0,01		967	Digital filter, Input IN1
dP5. 1	20		698	Position of decimal point for IN1
Lo5. 1	-19 999		LSW: 699 MSW: 700	Lower scale value, Input IN1
Hi 5. 1	20 000		LSW: 701 MSW: 702	Upper scale value, Input IN1
OF5. 1	0		703	Offset, Input IN1
56OF. 1	0,000		704	Offset, Input IN1, calibrated using 40mV upper scale value
56SE. 1	3,000		705	Sensitivity, Input IN1, calibrated using 40 mV upper scale value

Table 11: Menu / nP.2

Display	Default value	CONF	MOD bus	Description
TYPE.2	15		706	Sensor or signal type for input IN2
FILT.2	0,01		707	Digital filter, Input IN2
DP5.2	0		708	Position of decimal point for IN2
LoS.2	-3 000		LSW: 709 MSW: 710	Lower scale value, Input IN2
Hi S.2	3 000		LSW: 711 MSW: 712	Upper scale value, Input IN2
OFF.2	0		713	Offset, Input IN2
56OF.2	0,000		714	Offset, Input IN2, calibrated using 40mV upper scale value
56SE.2	4,000		715	Sensitivity, Input IN2, calibrated using 40mV upper scale value

Table 12: Menu / nP.3

Display	Default value	CONF	MOD bus	Description
TYPE.3	1		716	Sensor or signal type for input IN3
FILT.3	0,02		717	Digital filter, Input IN3
DP5.3	3		718	Position of decimal point for IN3
LoS.3	0,00		LSW: 719 MSW: 720	Lower scale value, Input IN3
Hi S.3	100,00		LSW: 721 MSW: 722	Upper scale value, Input IN3
OFF.3	0,00		723	Offset, Input IN3

Table 13: Menu / nP.4

Display	Default value	CONF	MOD bus	Description
TYPE.4	2		724	Sensor or signal type for input IN4
FILT.4	0,02		725	Digital filter, Input IN4
DP5.4	3		726	Position of decimal point for IN4
LoS.4	0,0		LSW: 727 MSW: 728	Lower scale value, Input IN4
Hi S.4	2 000,0		LSW: 729 MSW: 730	Upper scale value, Input IN4
OFF.4	0,0		731	Offset, Input IN4

Table 14: Menu *ALL*

Display	Default value	CONF	MOD bus	Description
<i>Ar.1</i>	0		732	Reference for Limit 1
<i>At.1</i>	0		733	Type of limit 1
<i>Hy.1</i>	-1		734	Hysteresis for limit 1
<i>rA.1</i>	0		735	Activation time for limit 1
<i>bt.1</i>	0		736	Time base for activation time for limit 1
<i>SdA.1</i>	0		1283	Character A of character string for limit 1
<i>Sdb.1</i>	0		1284	Character B of character string for limit 1
<i>SdC.1</i>	0		1285	Character C of character string for limit 1
<i>Sdd.1</i>	0		1286	Character D of character string for limit 1
<i>SdE.1</i>	0		1287	Character E of character string for limit 1
<i>Ar.2</i>	0		737	Reference for Limit 2
<i>At.2</i>	0		738	Type of limit 2
<i>Hy.2</i>	-1		739	Hysteresis for limit 2
<i>rA.2</i>	0		740	Activation time for limit 2
<i>bt.2</i>	0		741	Time base for activation time for limit 2
<i>SdA.2</i>	0		1288	Character A of character string for limit 2
<i>Sdb.2</i>	0		1289	Character B of character string for limit 2
<i>SdC.2</i>	0		1290	Character C of character string for limit 2
<i>Sdd.2</i>	0		1291	Character D of character string for limit 2
<i>SdE.2</i>	0		1292	Character E of character string for limit 2
<i>Ar.3</i>	0		742	Reference for Limit 3
<i>At.3</i>	0		743	Type of limit 3
<i>Hy.3</i>	-1		744	Hysteresis for limit 3
<i>rA.3</i>	0		745	Activation time for limit 3
<i>bt.3</i>	0		746	Time base for activation time for limit 3
<i>SdA.3</i>	0		1293	Character A of character string for limit 3
<i>Sdb.3</i>	0		1294	Character B of character string for limit 3
<i>SdC.3</i>	0		1295	Character C of character string for limit 3

Display	Default value	CONF	MOD bus	Description
<i>Sdd.3</i>	0		1296	Character D of character string for limit 3
<i>SdE.3</i>	0		1297	Character E of character string for limit 3
<i>Ar.4</i>	0		747	Reference for Limit 4
<i>At.4</i>	32		748	Type of limit 4
<i>Hy.4</i>	-1		749	Hysteresis for limit 4
<i>rA.4</i>	0		750	Activation time for limit 4
<i>bt.4</i>	0		751	Time base for activation time for limit 4
<i>SdA.4</i>	0		1298	Character A of character string for limit 4
<i>SdB.4</i>	0		1299	Character B of character string for limit 4
<i>SdC.4</i>	0		1300	Character C of character string for limit 4
<i>Sdd.4</i>	0		1301	Character D of character string for limit 4
<i>SdE.4</i>	0		1302	Character E of character string for limit 4

Table 15: Menu *Out*

Display	Default value	CONF	MOD bus	Description
<i>rL.1</i>	1		787	Reference for output, OUT1
<i>rL.2</i>	2		789	Reference for output, OUT2
<i>rL.3</i>	3		791	Reference for output, OUT3
<i>rL.4</i>	4		793	Reference for output, OUT4
<i>tYP.An</i>	5		799	Type of analog output W
<i>rIF.An</i>	0		800	Reference, Output W
<i>Lo.An</i>	-19 999		LSW: 801	Lower scale value, Output W
<i>Hi .An</i>	20 000		MSW: 803	Upper scale value, Output W
<i>AL5</i>	1		807	Sensor-excitation selection

Table 16: Menu *PR5*

Display	Default value	CONF	MOD bus	Description
<i>PR5</i>	0			Password
<i>Pro</i>	0		49	Protection code

Table 17: Menu *Hrd*

Display	Default value	CONF	MOD bus	Description
<i>hd.1</i>	0		809	
<i>F_{unc.A}</i>	0		815	Mathematical function A
<i>ln1.A</i>	0		816	First operand of <i>F_{unc.A}</i>
<i>ln2.A</i>	0		817	Second operand of <i>F_{unc.A}</i>
<i>OPeR.A</i>	0		818	Operator of <i>F_{unc.A}</i>
<i>C1.A</i>	0,00		819	Coefficient <i>C1.A</i>
<i>C2.A</i>	0		820	Coefficient <i>C2.A</i>
<i>C3.A</i>	0,00		821	Coefficient <i>C3.A</i>
<i>C4.A</i>	0		822	Coefficient <i>C4.A</i>
<i>C5.A</i>	0,00		823	Coefficient <i>C5.A</i>
<i>F_{unc.b}</i>	0		824	Mathematical function b
<i>ln1.b</i>	0		825	First operand of <i>F_{unc.b}</i>
<i>ln2.b</i>	0		826	Second operand of <i>F_{unc.b}</i>
<i>OPeR.b</i>	0		827	Operator of <i>F_{unc.b}</i>
<i>C1.b</i>	0,00		828	Coefficient <i>C1.b</i>
<i>C2.b</i>	0		829	Coefficient <i>C2.b</i>
<i>C3.b</i>	0,00		830	Coefficient <i>C3.b</i>
<i>C4.b</i>	0		831	Coefficient <i>C4.b</i>
<i>C5.b</i>	0,00		832	Coefficient <i>C5.b</i>
<i>AL.n</i>	4		834	Number of active limits
<i>but.1</i>	8		835	[PEAK] button function
<i>but.2</i>	11		836	[CAL/RST] button function
<i>but.3</i>	23		837	[★] button function
<i>dl5.1</i>	0		838	Function of digital input DI1
<i>dl5.2</i>	0		839	Function of digital input DI2
<i>FLd</i>	0,5		846	Digital filter for PV display
<i>d5.SP</i>	17		847	Selection of variable displayed on PV display

Display	Default value	CONF	MOD bus	Description
d5.F	8		848	Selection of variable displayed on F display
d5.PU	16		1279	Selection of units for F display for In.1
5d5.SP	17		1280	Selection of units for F display for In.2
5d5.F	18		1281	Selection of units for F display for In.3
5d5.PU	19		1282	Selection of units for F display for In.4
LEd.1	22		849	LED 1 function
LEd.2	41		850	LED 2 function
LEd.3	0		851	LED 3 function
LEd.4	0		852	LED 4 function

Table 18: Menu L_n

Display	Default value	CONF	MOD bus	Description
tYP.L	1		858	Linearization type
StEP.n	4		859	Number of intervals
5.00	0		LSW: 860 MSW: 861	Point 0, value assigned to lower scale value (step 0)
5.01_A	2 500		LSW: 862 MSW: 863	Point 1, input value [1/10,000] of upper scale value. (step 1)
5.01_b	5 000		LSW: 864 MSW: 865	Value assigned to point 1 (step 2)
5.02_A	5 000		LSW: 866 MSW: 867	Point 2, input value [1/10,000] of upper scale value. (step 3)
5.02_b	10 000		LSW: 868 MSW: 869	Value assigned to point 2 (step 4)
5.03_A	7 500		LSW: 870 MSW: 871	Point 3, input value [1/10,000] of upper scale value. (step 5)
5.03_b	15 000		LSW: 872 MSW: 873	Value assigned to point 3 (step 6)
5.04_A	9 999		LSW: 874 MSW: 875	Point 4, input value [1/10,000] of upper scale value. (step 7)



Display	Default value	CONF	Profibus	Description
5.04_b	20 000		LSW: 876 MSW: 877	Value assigned to point 4 (step 8)
5.05_A	0		LSW: 878 MSW: 879	Point 5, input value [1/10,000] of upper scale value. (step 9)
5.05_b	0		LSW: 880 MSW: 881	Value assigned to point 5 (step 10)
5.06_A	0		LSW: 882 MSW: 883	Point 6, input value [1/10,000] of upper scale value. (step 11)
5.06_b	0		LSW: 884 MSW: 885	Value assigned to point 6 (step 12)
5.07_A	0		LSW: 886 MSW: 887	Point 7, input value [1/10,000] of upper scale value. (step 13)
5.07_b	0		LSW: 888 MSW: 889	Value assigned to point 7 (step 14)
5.08_A	0		LSW: 890 MSW: 891	Point 8, input value [1/10,000] of upper scale value. (step 15)
5.08_b	0		LSW: 892 MSW: 893	Value assigned to point 8 (step 16)
5.09_A	0		LSW: 894 MSW: 895	Point 9, input value [1/10,000] of upper scale value. (step 17)
5.09_b	0		LSW: 896 MSW: 897	Value assigned to point 9 (step 18)
5.10_A	0		LSW: 898 MSW: 899	Point 10, input value [1/10,000] of upper scale value. (step 19)
5.10_b	0		LSW: 900 MSW: 901	Value assigned to point 10 (step 20)
5.11_A	0		LSW: 902 MSW: 903	Point 11, input value [1/10,000] of upper scale value. (step 21)
5.11_b	0		LSW: 904 MSW: 905	Value assigned to point 11 (step 22)
5.12_A	0		LSW: 906 MSW: 907	Point 12, input value [1/10,000] of upper scale value. (step 23)
5.12_b	0		LSW: 908 MSW: 909	Value assigned to point 12 (step 24)

Display	Default value	CONF	Profibus	Description
5.13_A	0		LSW: 910 MSW: 911	Point 13, input value (step 25) [1/10,000] of upper scale value.
5.13_b	0		LSW: 912 MSW: 913	Value assigned to point 13 (step 26)
5.14_A	0		LSW: 914 MSW: 915	Point 14, input value (step 27) [1/10,000] of upper scale value.
5.14_b	0		LSW: 916 MSW: 917	Value assigned to point 14 (step 28)
5.15_A	0		LSW: 918 MSW: 919	Point 15, input value (step 29) [1/10,000] of upper scale value.
5.15_b	0		LSW: 920 MSW: 921	Value assigned to point 15 (step 30)
5.16_A	0		LSW: 922 MSW: 923	Point 16, input value (step 31) [1/10,000] of upper scale value.
5.16_b	0		LSW: 924 MSW: 925	Value assigned to point 16 (step 32)
5.17_A	0		LSW: 926 MSW: 927	Point 17, input value (step 33) [1/10,000] of upper scale value.
5.17_b	0		LSW: 928 MSW: 929	Value assigned to point 17 (step 34)
5.18_A	0		LSW: 930 MSW: 931	Point 18, input value (step 35) [1/10,000] of upper scale value.
5.18_b	0		LSW: 932 MSW: 933	Value assigned to point 18 (step 36)
5.19_A	0		LSW: 934 MSW: 935	Point 19, input value (step 37) [1/10,000] of upper scale value.
5.19_b	0		LSW: 936 MSW: 937	Value assigned to point 19 (step 38)
5.20_A	0		LSW: 938 MSW: 939	Point 20, input value (step 39) [1/10,000] of upper scale value.
5.20_b	0		LSW: 940 MSW: 941	Value assigned to point 20 (step 40)



Display	Default value	CONF	Profibus	Description
5.21_A	0		LSW: 942 MSW: 943	Point 21, input value [1/10,000] of upper scale value. (step 41)
5.21_b	0		LSW: 944 MSW: 945	Value assigned to point 21 (step 42)
5.22_A	0		LSW: 946 MSW: 947	Point 22, input value [1/10,000] of upper scale value. (step 43)
5.22_b	0		LSW: 948 MSW: 949	Value assigned to point 22 (step 44)
5.23_A	0		LSW: 950 MSW: 951	Point 23, input value [1/10,000] of upper scale value. (step 45)
5.23_b	0		LSW: 952 MSW: 953	Value assigned to point 23 (step 46)
5.24_A	0		LSW: 954 MSW: 955	Point 24, input value [1/10,000] of upper scale value. (step 47)
5.24_b	0		LSW: 956 MSW: 957	Value assigned to point 24 (step 48)
5.25_A	0		LSW: 958 MSW: 959	Point 25, input value [1/10,000] of upper scale value. (step 49)
5.25_b	0		LSW: 960 MSW: 961	Value assigned to point 25 (step 50)
5.26_A	0		LSW: 962 MSW: 963	Point 26, input value [1/10,000] of upper scale value. (step 51)
5.26_b	0		LSW: 964 MSW: 965	Value assigned to point 26 (step 52)
5.27_A	0		LSW: 966 MSW: 967	Point 27, input value [1/10,000] of upper scale value. (step 53)
5.27_b	0		LSW: 968 MSW: 969	Value assigned to point 27 (step 54)
5.28_A	0		LSW: 970 MSW: 971	Point 28, input value [1/10,000] of upper scale value. (step 55)
5.28_b	0		LSW: 972 MSW: 973	Value assigned to point 28 (step 56)

Display	Default value	CONF	Profibus	Description
5.29_A	0		LSW: 974 MSW: 975	Point 29, input value (step 57) [1/10,000] of upper scale value.
5.29_b	0		LSW: 976 MSW: 977	Value assigned to point 29 (step 58)
5.30_A	0		LSW: 978 MSW: 979	Point 30, input value (step 59) [1/10,000] of upper scale value.
5.30_b	0		LSW: 980 MSW: 981	Value assigned to point 30 (step 60)
5.31_A	0		LSW: 982 MSW: 983	Point 31, input value (step 61) [1/10,000] of upper scale value.
5.31_b	0		LSW: 984 MSW: 985	Value assigned to point 31 (step 62)
5.32_A	0		LSW: 986 MSW: 987	Point 32, input value (step 63) [1/10,000] of upper scale value.
5.32_b	0		LSW: 988 MSW: 989	Value assigned to point 32 (step 64)
5.tc1	0,00		990	Step mV lower scale limit - only for Tc custom
5.tc2	0,00		991	Step mV upper scale limit - only for Tc custom
5.tc3	0,000		992	Step mV for temperature 50°C - only for Tc custom

18.2 Block diagram

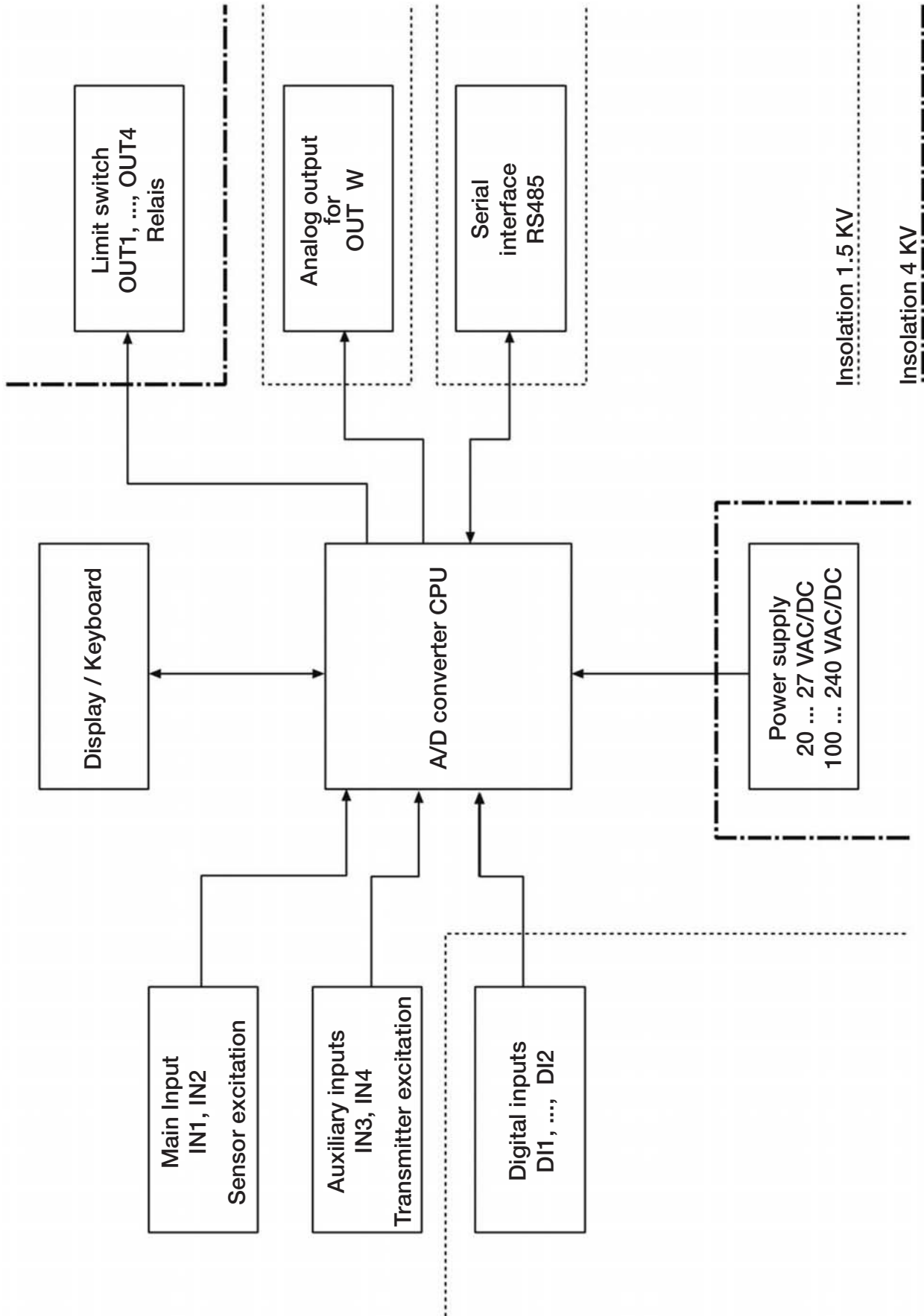

18.3 Functional block diagram

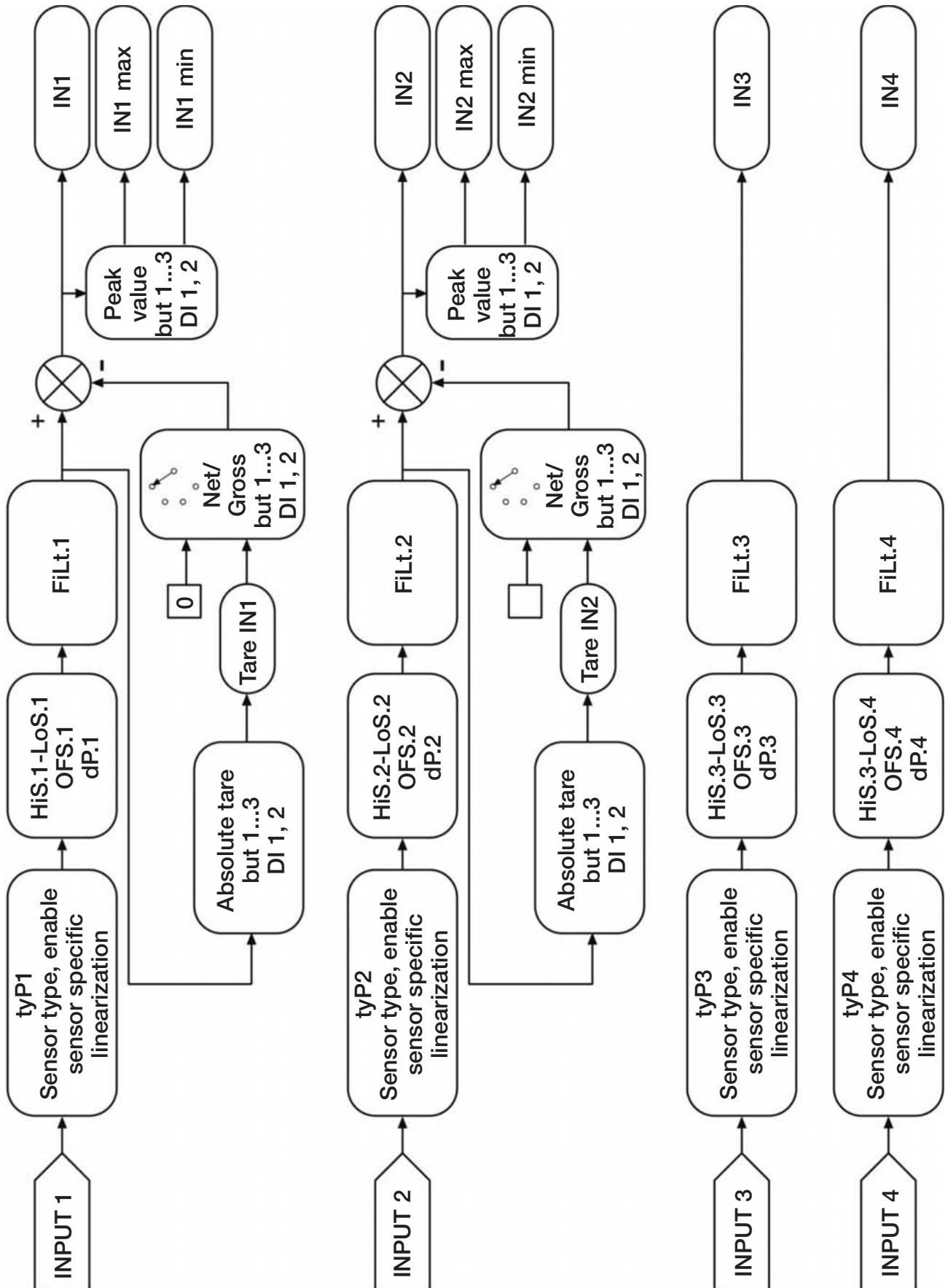

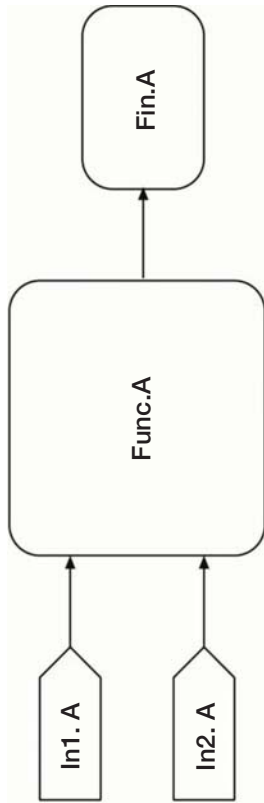

IN1...4
Fin.b

IN1...4
Fin.b

$$\text{Fin.A} = \frac{(C1.A * \text{In1.A})^{C2.A} \text{OPERa} (C3.A * \text{In2.A})^{C4.A}}{C5.A}$$

OPER.A = +, -, *, /

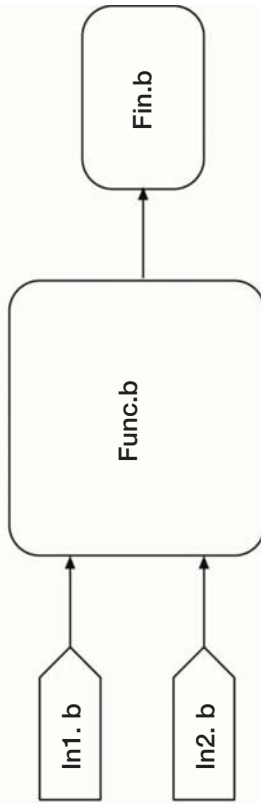

IN1...4
Fin.A

IN1...4
Fin.A

$$\text{Fin.b} = \frac{(C1.b * \text{In1.b})^{C2.b} \text{OPERb} (C3.b * \text{In2.b})^{C4.b}}{C5.b}$$

OPER.b = +, -, *, /

Example:

	In1	In.b	OPER	C1	C2	C3	C4	C5
IN1 + IN2	IN1	IN2	+	1	1	1	1	1
IN1 - IN2	IN1	IN2	-	1	1	1	1	1
IN1 / IN2	IN1	IN2	/	1	1	1	1	1
Square-root N1	IN1	0	+	1	0,5	0	1	1
(IN1 + IN2) / 2	IN1	IN2	+	1	1	1	1	2
IN3 * C1	IN1	0	+	C1	1	0	1	1

