

Precision Tension and Compression Load Cell

MODEL 8524



Large measuring ranges



Medium measuring ranges
(with accessories)



Small measuring ranges

Highlights

- Measuring ranges from 0 ... 500 N up to 0 ... 200 kN
- Non-linearity 0.25 % F.S.
- Particularly versatile
- Cable suitable for drag chains and highly flexible

Options

- Non-linearity 0.1 % F.S.
- Extended temperature range of -30 ... +120 °C
- Standardized nominal sensitivity 1.5 mV/V
- burster TEDS
- Overload protection up to 5 times the nominal force
- Pull plate and rod end bearings

Applications

- All areas of mechanical engineering
- Assembly and joining equipment
- Hydraulic presses
- Measurement of cable strengths

Product description

The 8524 precision tension & compression load cell is a versatile sensor for highly accurate load measurements in diverse applications. Optimum measurement quality is achieved with the load cell mounted on a flat, hard and polished contact surface. This requirement does not apply to small measurement ranges of up to 0 ... 2 kN because three knife-edge bearings ensure that the sensor is seated securely. Off-center forces, bending moments and torques of less than 5% of the rated load will not impair the sensor's measurement quality. Our brochure „Load Cells“ explains how you can design parasitic loads out of your mechanical system.

Through-holes in the outer flange are used for fastening the 8524 sensor to the system structure. The load is applied via the central blind threaded hole or optionally via a load button. Alternatively, a pull plate and even rod end bearings, if desired, can be attached to the sensor for equally easy measurement of purely tensile loads, for instance in Bowden cables or chains. The 8524 sensor is designed to measure static, quasi-static and dynamic compressive and/or tensile loads.

Inside the sensor is an elastic membrane, on which are applied strain gages connected in a full Wheatstone bridge. If a tensile or compressive load is applied to the sensor, the ohmic resistance of the measuring bridge changes and detunes the output signal in proportion to the measured load in mV/V.

Technical Data

8524	-	5500	6001	6002	6005	6010	6020	6050	6100	6200	
Measuring range calibrated in N and kN from 0 ...		±0,5 kN	±1 kN	±2 kN	±5 kN	±10 kN	±20 kN	±50 kN	±100 kN	±200 kN	
		±112.4 lbs	±224.8 lbs	±449.6 lbs	±1.1 klbs	±2.2 klbs	±4.5 klbs	±11.2 klbs	±22.5 klbs	±45.0 klbs	
Accuracy											
Relative non-linearity*		≤ ±0.25 % F.S. (option: ≤ ±0.1 % F.S.)									
Characteristic curve deviation*		≤ ±0.25 % F.S.									
Relative hysteresis		≤ 0.2 % F.S.				≤ 0.25 % F.S.					
Temperature effect on zero output		≤ 0.02 % F.S./K									
Temperature effect on nominal sensitivity		≤ 0.02 % F.S./K									
Electrical values											
Sensitivity nominal		1.6 mV/V									
Measurement direction		Tension and compression direction. Load calibration in compression direction. The full-scale output is likely to be different when used in the tension direction.									
Standardization		1,5 mV/V (±0,25 %), option realized on an circuit board 48 x 7 mm (L x W) at the cable after 1.7 m from sensor or 0.3 m from cable end									
Bridge resistance		350 Ω nominal (deviations are possible)									
Excitation		recommended 5 V DC or AC / max. 10 V DC or AC									
Insulation resistance		> 30 MΩ at 45 V									
Environmental conditions											
Nominal temperature range**		+15 °C ... +70 °C (option: -30 °C ... +120 °C)									
Operating temperature range		-30 °C ... +80 °C									
Mechanical values											
Deflection full scale	[µm]	< 80									
Maximum operating force		150 % of capacity									
Overload burst		> 250 % of capacity									
Dynamic performance		recommended: 70 % of capacity maximum: 100 % of capacity									
Protection class (EN 60529)		IP65					IP67				
Other											
Material		stainless steel 1.4542									
Natural frequency	[kHz]	> 2	> 3	> 5	> 8	> 12	> 4	> 3	> 5		
Mass	[kg]	0.25			0.65			2.0	5.0		

* The data in the area 20 % - 100 % of rated load F_{nom}

** Temperature range for the optional TEDS or standardization board 0 ... 60 °C

Dimensional drawing 1 – Measuring ranges from 0 ... ±0.5 kN up to 0 ... ±2 kN | from 0 ... ±112.4 lbs up to 0 ... ±449.6 lbs

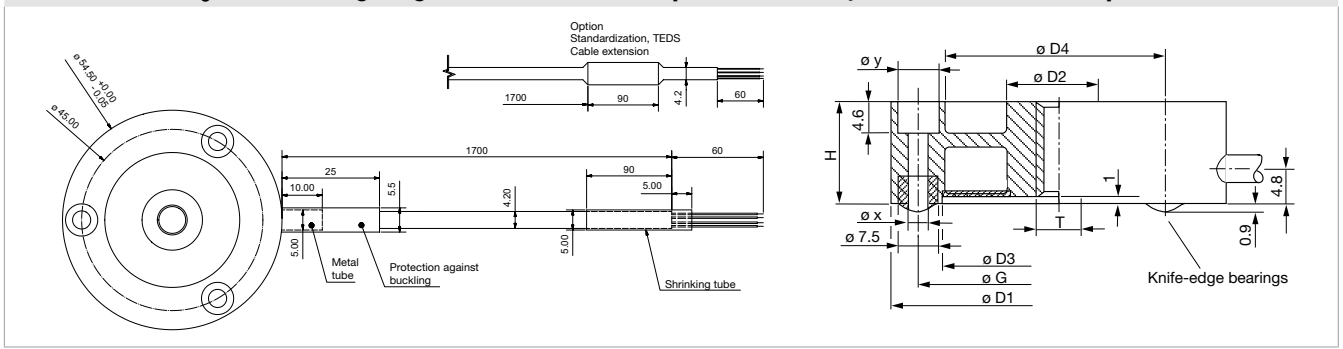

Dimensional drawing 2 – Measuring ranges from 0 ... ±5 kN up to 0 ... ±10 kN | from 0 ... ±1.1 klbs up to 0 ... ±2.2 klbs

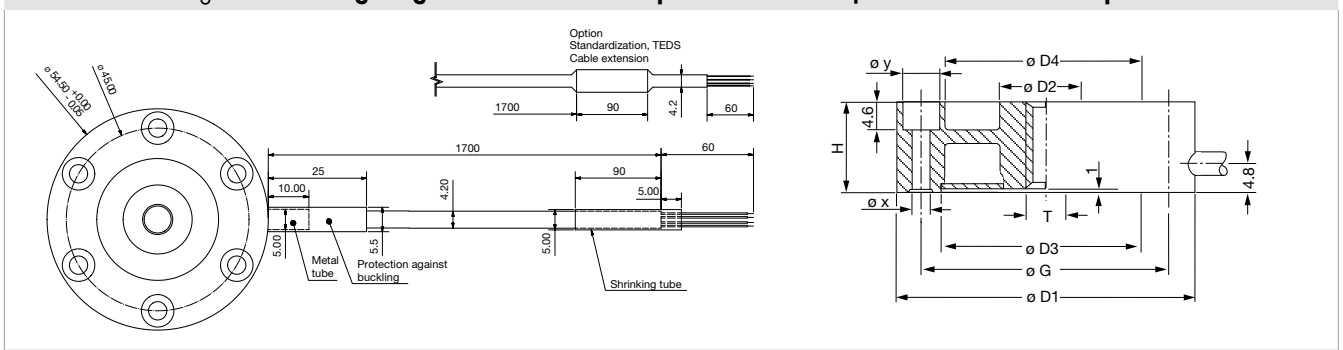

Dimensional drawing 3 – Measuring ranges from 0 ... ±20 kN up to 0 ... ±50 kN | from 0 ... ±4.5 klbs up to 0 ... ±11.2 klbs

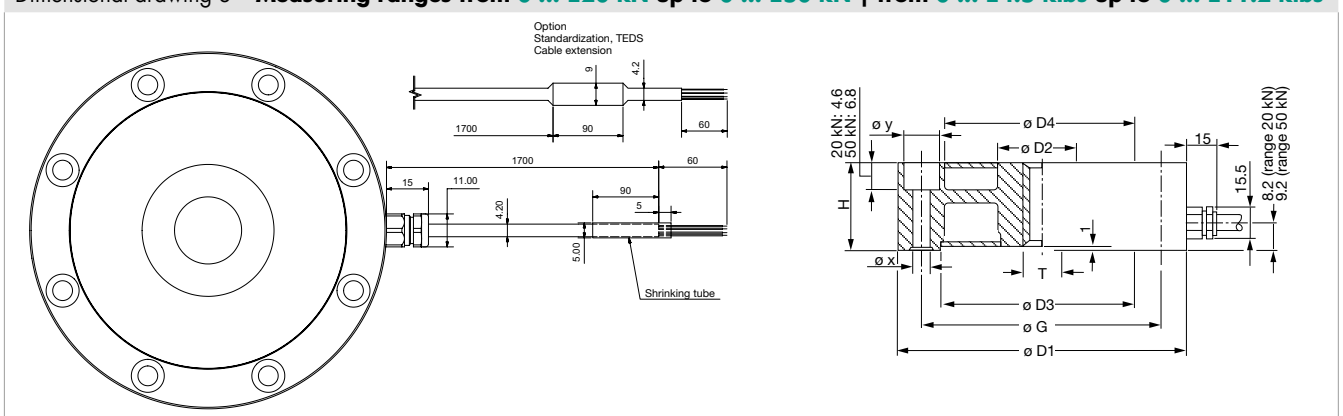

Dimensional drawing 4 – Measuring ranges from 0 ... ±100 kN up to 0 ... ±200 kN | from 0 ... ±22.5 klbs up to 0 ... ±45.0 klbs

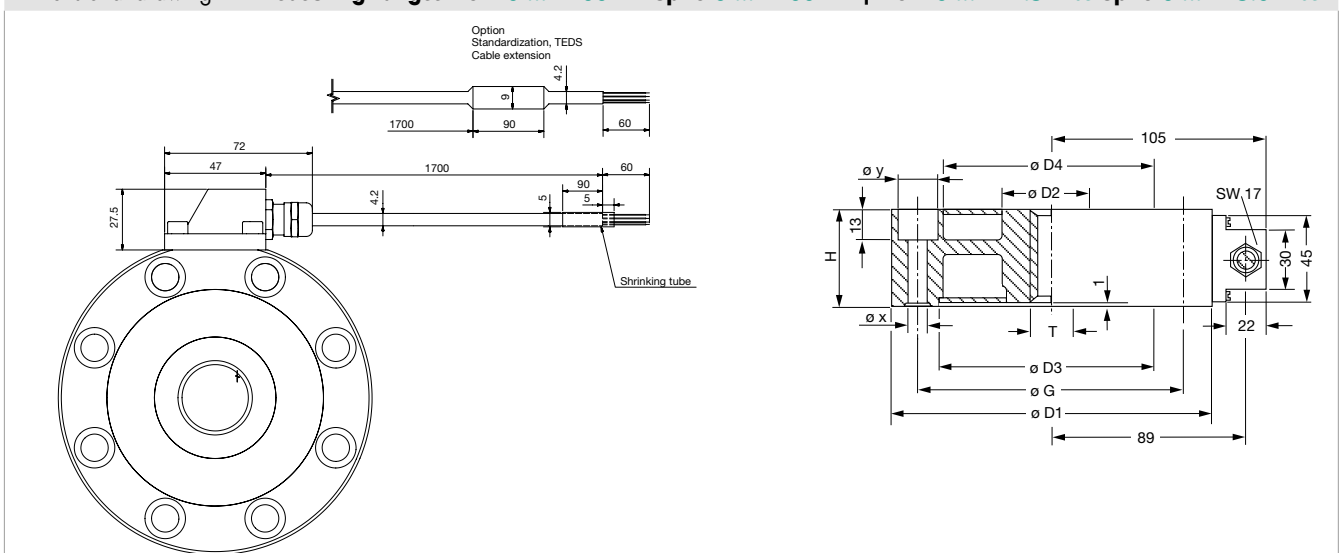

** at standardization or cable extension

8524	-	5500	6001	6002	6005	6010	6020	6050	6100	6200
Measuring range from 0 ...		±0.5 kN	±1 kN	±2 kN	±5 kN	±10 kN	±20 kN	±50 kN	±100 kN	±200 kN
Geometry										
Ø D1	[mm]	54.5					79.0	119.0	155.0	
Ø D2	[mm]	15.0			17.0		22.0	44.0	60.0	
Ø D3	[mm]	35.5					59.0	94.0	109.0	
Ø D4	[mm]	33.5			30.0		58.6	92.6	107.0	
H	[mm]	16.0					25.0	35.0	50.0	
G	[mm]	45.0					68.0	105.0	129.0	
Ø X	[mm]	4.5						6.6	13.5	
Ø Y	[mm]	8.0						11.0	20.0	
Central blind threaded hole T		M8 x 1.25					M12 x 1.5	M24 x 1.5	M36 x 3	
Number of clearing holes in Ø		3 (with edges, H + 1 mm)			6		8			
Dimensional drawings		dimensional drawing 1			dimensional drawing 2		dimensional drawing 3 & 4			
General tolerance of dimension		ISO 2768f								
Installation										
Intended mounting screws		M4					M6	M12		
Tightening torque mounting screws (when used in tension direction)	[N*m]	3					10	100		
Mounting screws		resistance 12.9 or higher								
Installation instructions		The entire bearing area of the sensor must be mounted on a base which is hardened (60 HRC), flat, polished or better lapped. Counter bores in compliance with DIN 74-km, in compliance with DIN 912 head cap screws								

Electrical termination

Output signal

burster load cells are based on a strain-gage Wheatstone bridge. This measurement principle means that the output voltage mV/V is highly dependent on the sensor supply voltage. Our website contains details of suitable instrumentation amplifiers, indicator and display devices and process instruments.



burster TEDS

The "burster Transducer Electronic Data Sheet" (TEDS) is a memory in which identification data of the sensor, calibration data and other sensor parameters are saved. In conjunction with your own suitable burster device, there is the option of performing a simple adjustment in order to achieve the maximum accuracy of the measuring chain. A simple sensor exchange is thus possible in just a few steps without losing precision.

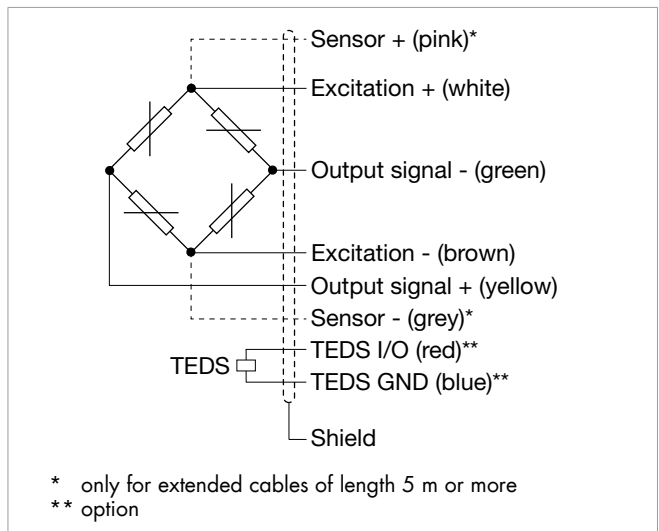

8524	-	5500	6001	6002	6005	6010	6020	6050	6100	6200
Measuring range from 0 ...		±0.5 kN	±1 kN	±2 kN	±5 kN	±10 kN	±20 kN	±50 kN	±100 kN	±200 kN
Electrical termination										
Cable specifications		Highly flexible, oil resistant, drag chains suitable. Bending radius three times the diameter for fixed cable, ten times the diameter for cable permanently moving.								
Cable model		PUR, Ø = 4.2 mm								

Options

Overload protection in compression direction

The optional overload protection guards a load cell against damage under a static load that exceeds the safe load (150% of the rated load). The overload protection is available up to the measurement range of ≤ 20 kN. Protection is achieved via a mechanical stop, which limits the measurement displacement of the sensor (to about $80 \mu\text{m}$). The overload protection contains additional holes for mounting on a fixed system structure, which then allows the transmission and measurement of tensile loads as well.

- Overload protection for compression only
- Measuring tension and compression load
- Overload protection mounting by factory only
- Tolerance of standardized output with overload protection at 0.5 % F.S.
- Do not use the overload protection often
- Overload protection does not have any centric threaded holes

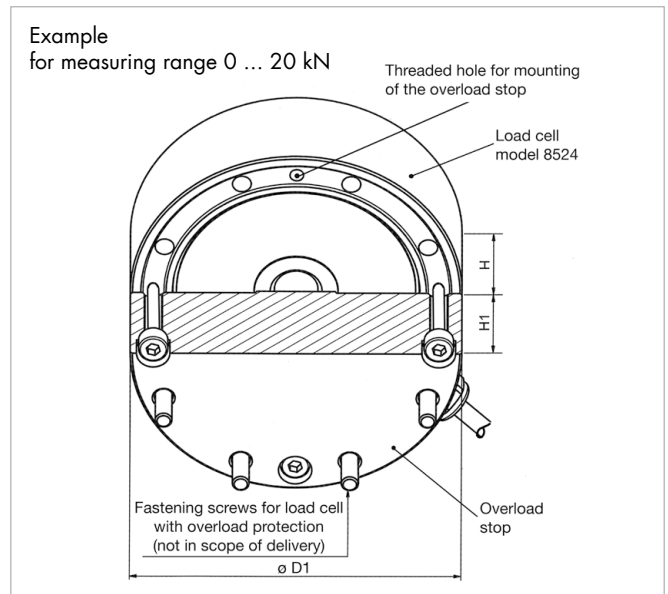

Order number	see order code									
Compatible for measuring range from 0 ...	± 0.5 kN	± 1 kN	± 2 kN	± 5 kN	± 10 kN	± 20 kN	-	-	-	-
Geometry										
Overload protection	2.5 kN	5 kN	10 kN	20 kN	30 kN	80 kN	-	-	-	-
$\varnothing D1$	54.5					79	-	-	-	-
H1	19					25	-	-	-	-
H	16					25	-	-	-	-
Other										
Mass	[kg]	0.3		0.7	0.8	-	-	-	-	-

Pull plates (8590-V...)

A pull plate extends the range of potential uses of tension & compression load cells to measuring tensile loads in moving assemblies (cable tension or forces in joints). The pull plate is fastened by its outer flange to the sensor's flange. Customized threaded parts or even rod end bearings can be fitted in the central threaded hole. Once fitted, the pull plates form part of the sensor. Sensor and plate are calibrated as a unit and are supplied only as a pre-assembled combination. Bolts of strength 12.9 are required for fitting the pull plates.

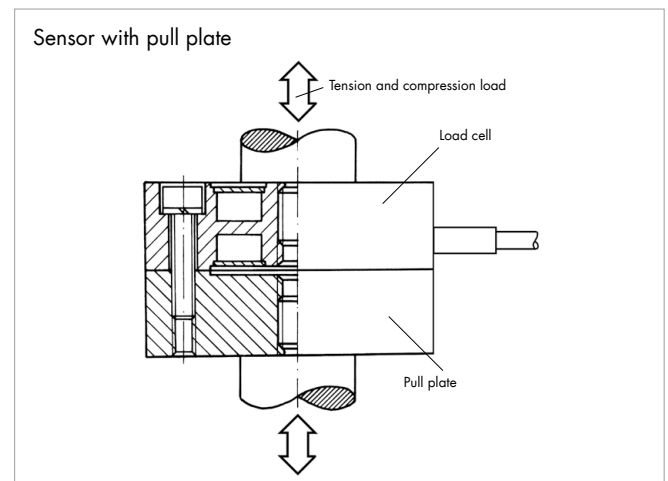

Order number	see order code									
Compatible for measuring range from 0 ...	± 0.5 kN	± 1 kN	± 2 kN	± 5 kN	± 10 kN	± 20 kN	± 50 kN	± 100 kN	± 200 kN	
Geometry										
Central blind threaded hole T	M8 x 1.25					M12 x 1.5	M24 x 1.5	M36 x 3		
Installation										
Tightening torque mounting screws	[N*m]	3					10			
Other										
Mass	[kg]	0.28			0.7	2.2	5.5			

Accessories

Rod end bearings

The 8524 load cell can be optionally supplied with a rod end bearing. In combination with a pull plate (see option), up to two rod end bearings can be used. Rod end bearings ensure optimum load application when the sensor is used in the tension direction. In addition, they can compensate for slight misalignment in the compression direction.

- Optimal force introduction
- Compensation of misalignments
- Very high dynamic und static load capacity
- Material: stainless steel
- Temperature range: - 45 °C to + 120 °C
- PTFE insert, maintenance-free
- DIN 648 series K
- Bore holes H7, recommended connection pin: g6
- Inner ring not suitable for permanent rotary operation

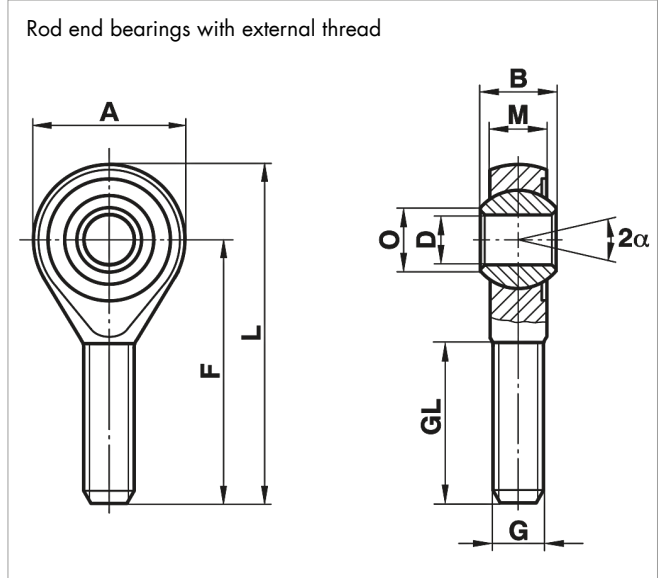

Order Code

8591	-	Z08M	Z12M	Z24M	Z36M
B	[mm]	12	16	31	43
M	[mm]	9	12	22	28
A	[mm]	24	32	60	80
F	[mm]	42	54	94	125
L	[mm]	54	70	124	165
O	[mm]	10.4	15.4	29.6	37.7
D	[mm]	8	12	25	35
G		M8 x 1.25	M12 x 1.5	M24 x 1.5	M36 x 3.0
GL	[mm]	25	33	57	73
α	[°]	14	13	15	19

Other

Stat. load factor	[kN]	19.5	42.0	118.0	230.0
Dyn. load factor	[kN]	16.7	32.0	122.0	205.0
Weight	[g]	33	87	600	1600

Load buttons

Load buttons are used when purely compressive forces are meant to be applied to the load cell and when direct coupling to the surrounding mechanical structure via the central threaded hole in the sensor is not required/possible. The domed surface of the load button minimizes angle errors for loads applied at an angle of up to 3°. The compressive force must be applied to the button via a flat and hardened contact surface. The optimum hardness is 60 HRC or more.

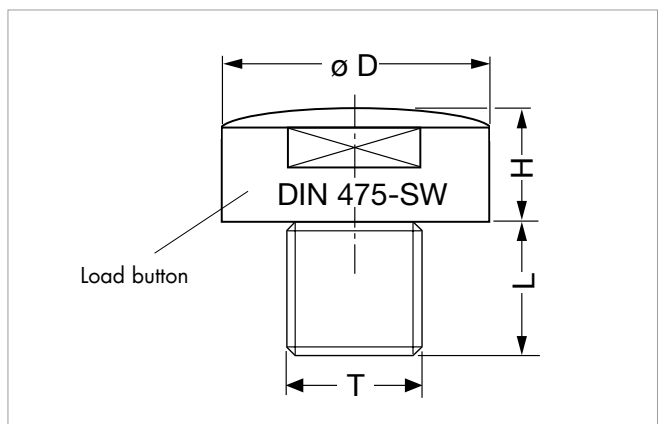

Order Code

8580	-	V008					V012	V024	V036	
Compatible for measuring range from 0 ...		±0.5 kN	±1 kN	±2 kN	±5 kN	±10 kN	±20 kN	±50 kN	±100 kN	±200 kN
Geometry										
∅ D	[mm]	14.0					20.0	40.0	57.0	
H	[mm]	7.3					15.1	20.0	30.0	
L	[mm]	7.0					12.0	17,0	40.0	
T		M8 x 1.25					M12 x 1.5	M24 x 1.5	M36 x 3	
SW	[mm]	-					16	32	46.0	
R		20					25	100	200.0	
Installation										
Tightening torques	[N*m]	max. 5			max. 8		max. 10	max. 20	max. 50	
Other										
Mass	[kg]	0.01					0.05	0.25	1	

Connectors and units**Order Code**

Connectors	
9941	Connectors 12 pin, suitable to all burster desktop units
9900-V209	Connectors 9 pin, suitable to SENSORMASTER, DIGIFORCE® and TRANS CAL
9900-V229	Connectors 9 pin with TEDS
9900-V245	Connectors 8 pin, suitable to ForceMaster
Units	
7281-V0001	Mobile measuring device with strain gage simulator and sensor test (R_i , R_o , Shunt, R_{ISO})
refer to section 9	Sensor electronics, amplifier and process control units like digital indicator model 9180, model 9163, modular amplifier model 9250 or DIGIFORCE® model 9307

Calibration

Test and calibration certificate	
Included in scope of delivery of sensor	Amongst other data, includes figures for zero point, full-scale output and calibration offset
Standard factory calibration certificate for load cells or measurement chains (WKS)	
Optionally available	Our standard factory calibration is performed in 20% steps starting from zero until the reaching the nominal force, for increasing and decreasing load with unchanged installation position. Factory calibration can be performed in compression and/or tension direction.
Special factory calibration certificate for load cells or measurement chains (WKS)	
On request	We are happy to calibrate sensors and measurement chains to the customer's specification.
Calibration certificate with accreditation symbol for product group load cell 8524	
Optionally available	Calibration certificate with accreditation symbol for load cell 8524. Calibration is performed on the basis of the accreditation of the calibration laboratory D-K-15141-01-00, for the scope of accreditation listed in the annex to the certificate. The traceability to national standards as well as a wide international recognition (DAkkS as signatory of the Multilateral Agreements of EA, ILAC and IAF) are thus guaranteed. Calibration is performed according to ISO 376 in 10 force steps (10% steps) vstarting from zero until the reaching the nominal force, for increasing and decreasing load under various installation positions.

Order Code

Measuring range	Code				Measuring range
0 ... ±0.5 kN	5	5	0	0	0 ... ±112.4 lbs
0 ... ±1 kN	6	0	0	1	0 ... ±224.8 lbs
0 ... ±2 kN	6	0	0	2	0 ... ±449.6 lbs
0 ... ±5 kN	6	0	0	5	0 ... ±1.1 klbs
0 ... ±10 kN	6	0	1	0	0 ... ±2.2 klbs
0 ... ±20 kN	6	0	2	0	0 ... ±4.5 klbs
0 ... ±50 kN	6	0	5	0	0 ... ±11.2 klbs
0 ... ±100 kN	6	1	0	0	0 ... ±22.5 klbs
0 ... ±200 kN	6	2	0	0	0 ... ±45.0 klbs

										Delivery ex stock at short notice										
										N	0	0	0	S	0	0	0			
8	5	2	4	-														0	0	
<ul style="list-style-type: none"> Nominal sensitivity/not standardized Standardization at 1.5 mV/V 										N										
<ul style="list-style-type: none"> Connection cable 1.7 m (Standardization 2 m) Connection cable 3 m Connection cable 5 m Connection cable 3 m extended * Connection cable 5 m extended * (with sens line) 										0	F	G	L	M						
* shortened delivery time compared with cable length 3 m and 5 m in one piece																				
<ul style="list-style-type: none"> Open cable ends + 6 cm single wires 9 pins Sub-D connector model 9900-V209 9 pins Sub-D connector model 9900-V209 for 9163-V3xxxx 12 pins round connector model 9941 for burster desktop devices 9 pins Sub-D connector with burster TEDS model 9900-V229 8 pins coupling connector model 9900-V245 for 9110 										O	B	E	F	T	H					
<ul style="list-style-type: none"> Non-linearity 0.25 % F.S. Non-linearity 0.1 % F.S. 										S	L									
<ul style="list-style-type: none"> No option Overload protection in compression direction (only for ranges up to 0 ... 20 kN) Pull plate 																	0	4	5	
<ul style="list-style-type: none"> Nominal temperature range +15 °C ... +70 °C Extended nominal temperature range -30 °C ... +120 °C 																			0	J

Note

- Brochure**
Our brochure „Load cells for production, automation, R&D and quality assurance“ is available for download on our website. It contains numerous applications, detailed product specifications and overviews.
- Product videos**
Watch our **How-to-do video** at: www.youtube.com/bursterVideo
- CAD data**
Download via www.burster.com or directly at www.traceparts.com

