

Data sheet

DF dual



Technical data

Type	-	DF2 dual
Accuracy class	%	≤±0.04
Rated torque (Md _n)	Nm	1,000

Torque measuring system

Technology	-	Rotating
Rated torque (Md _n) #1	Nm	1,000
Rated torque short measurement range (lower limit) (Md _{ns}) #2	Nm	200
Accuracy class (Md _{ns})	%	≤±0.04
Accuracy class extended (for Md _n)	%	N/A
Accuracy class extended (for Md _{ns})	%	N/A
Outputs	-	Frequency (RS422), Voltage, CAN bus, Alert
Test signal	-	see test report

Mechanical dimensions #3

Outer diameter of rotor #4	mm	128
Lengths (Rotor, without centering)	mm	48
Pitch circle diameter #5	mm	101.5

Speeds and speed measuring systems

Speed detection (integrated)	-	without
Speed detection (optional)	-	magn.
Maximum Speed without speed detection system	rpm	20,000
Optional increased speed	rpm	23,000
Maximum speed with magnetic speed encoder	rpm	11,000
Maximum speed with optical speed encoder	rpm	N/A
Maximum speed with inductive speed encoder	rpm	N/A

Technical data

Type	-	DF2 dual
Accuracy class	%	$\leq \pm 0.04$
Rated torque (M_{d_n})	Nm	1,000

Torque accuracy class per output type (related to M_{d_n})

Frequency output	%	$\leq \pm 0.04$
CAN output	%	$\leq \pm 0.04$
Voltage output	%	$\leq \pm 0.04$
Current output	%	N/A
Frequency output (option higher accuracy)	%	N/A
CAN (option higher accuracy)	%	N/A

Torque accuracy class per output type (related to $M_{d_{ns}}$)

Frequency output	%	$\leq \pm 0.04$
CAN output	%	$\leq \pm 0.04$
Voltage output	%	$\leq \pm 0.04$
Current output	%	N/A
Frequency output (option higher accuracy)	%	N/A
CAN (option higher accuracy)	%	N/A

Technical data

Type	-	DF2 dual
Accuracy class	%	≤±0.04
Rated torque (Md _n)	Nm	1,000
Linearity deviation including hysteresis related to Md_n #6		
Frequency, 0%...30%	%	≤±0.015
Frequency, 30%...60%	%	≤±0.030
Frequency, 60%...100%	%	≤±0.040
CAN, 0%...30%	%	≤±0.015
CAN, 30%...60%	%	≤±0.030
CAN, 60%...100%	%	≤±0.040
Voltage output	%	≤±0.04
Current output	%	N/A
Rel. standard deviation of the reproducibility according to DIN 1319, by reference to variation of the output signal (rel. to Md_n)		
Frequency output	%	≤±0.04
CAN output	%	≤±0.04
Voltage output	%	≤±0.04
Current output	%	N/A
Temperature influence per 10K in the nominal temperature range on the output signal related to the actual value of signal span (rel. to Md_n)		
Frequency output	%	≤±0.04
CAN output	%	≤±0.04
Voltage output	%	≤±0.04
Current output	%	N/A
Temperature influence per 10K in the nominal temperature range on the zero signal (rel. to Md_n)		
Frequency output	%	≤±0.04
CAN output	%	≤±0.04
Voltage output	%	≤±0.04
Current output	%	N/A
Long-term drift over 48h at reference temperature		
Voltage output	mV	<1.5 / <3.0 / <0.8 / <1.5
Current output	μA	N/A

Technical data

Type	-	DF2 dual
Accuracy class	%	≤±0.04
Rated torque (Md _n)	Nm	1,000

Linearity deviation including hysteresis related to Md_{ns} #6

Frequency, 0%...30%	%	≤±0.015
Frequency, 30%...60%	%	≤±0.030
Frequency, 60%...100%	%	≤±0.040
CAN, 0%...30%	%	≤±0.015
CAN, 30%...60%	%	≤±0.030
CAN, 60%...100%	%	≤±0.040
Voltage output	%	≤±0.04
Current output	%	N/A

Rel. standard deviation of the reproducibility according to DIN 1319, by reference to variation of the output signal (rel. to Md_{ns})

Frequency output	%	≤±0.04
CAN output	%	≤±0.04
Voltage output	%	≤±0.04
Current output	%	N/A

Temperature influence per 10K in the nominal temperature range on the output signal related to the actual value of signal span (rel. to Md_{ns})

Frequency output	%	≤±0.04
CAN output	%	≤±0.04
Voltage output	%	≤±0.04
Current output	%	N/A

Temperature influence per 10K in the nominal temperature range on the zero signal (rel. to Md_{ns})

Frequency output	%	≤±0.04
CAN output	%	≤±0.04
Voltage output	%	≤±0.04
Current output	%	N/A

Technical data

Type	-	DF2 dual
Accuracy class	%	±0.04
Rated torque (M _{d,n})	Nm	1,000

Nominal sensitivity (range between zero torque and rated torque)

Frequency output	kHz	5 / 20 / 30 / 120
Voltage output	V	5.0 / 10.0 / 2.5 / 5.0
Current output	mA	N/A

Output signal at zero torque

Frequency output	kHz	10 / 60 / 60 / 240
Voltage output	V	0.0 / 0.0 / 2.5 / 5.0
Current output	mA	N/A

Nominal output signal

Frequency output at positive nominal value	kHz	15 / 80 / 90 / 360
Frequency output at negative nominal value	kHz	5 / 40 / 30 / 120
Voltage output at positive nominal value	V	5 / 10 / 5 / 10
Voltage output at negative nominal value	V	-5 / -10 / 0 / 0
Current output at positive nominal value	mA	N/A
Current output at negative nominal value	mA	N/A

Max. modulation range

Frequency output	kHz	0...420
Voltage output	V	-12.0...12.0
Current output	mA	N/A

Group delay time (main TCU)

Frequency output	µs	300
Voltage output	µs	300
CAN bus	µs	800

Technical data

Type	-	DF2 dual
Accuracy class	%	±0.04
Rated torque (M _{d,n})	Nm	1,000

Speed measuring system Inductive (track at rotor)

Pulse per rev (PPR)	ppr.	N/A
Maximum speeds (related to PPR)	rpm	N/A
Max. output frequency (RS422)	kHz	N/A
Minimum speed for sufficient pulse stability	rpm	N/A

Speed measuring system Magneto resistive (2 tracks approx. 90 degree phase shifted)

Pulses per rev (PPR)	ppr.	808
Maximum speeds (related to PPR)	rpm	11,000
Max. output frequency (RS422)	kHz	149
Minimum speed for sufficient pulse stability	rpm	>0.1
Nominal clearance (sensor - pole ring)	mm	0.7
Working airgap (sensor - pole ring)	mm	0.1...1.0
Nominal axial displacement (rotor - stator) #7	mm	7.0
Tolerance to nominal axial displacement (rotor - stator)	mm	±0.5

Speed measuring system Optical

Pulses per rev (PPR)	ppr.	N/A
Maximum speeds (related to PPR)	rpm	N/A
Max. output frequency (RS422)	kHz	N/A
Minimum speed for sufficient pulse stability	rpm	N/A
Nominal radial displacement (rotor - stator)	mm	N/A
Tolerated radial displacement (rotor - stator) #7	mm	N/A
Nominal axial displacement (rotor - stator) #7	mm	N/A
Tolerance to nominal axial displacement (rotor - stator)	mm	N/A

Technical data

Type	-	DF2 dual
Accuracy class	%	≤±0.04
Rated torque (M _{d,n})	Nm	1,000

Angular measuring system		
Requirement	-	Optional magnetic speed detection
Pulses per rev	ppr.	808
Resolution	°	0.111
Output signals	-	CAN bus, Voltage
Measurement ranges	°	0.00...360.00 / -180.00...180.00 / -360.00...360.00 / -720.00...720.00 / -1,080.00...1,080.00 / -1,440.00...1,440.00 / -1,800.00...1,800.00

Technical data

Type	-	DF2 dual
Accuracy class	%	±0.04
Rated torque (M_{d_n})	Nm	1,000

Temperature ranges

Nominal temperature range (<i>Rotor</i>)	°C	0...80
Operating temperature range (<i>Rotor</i>) #8	°C	-20...85
Storage temperature range (<i>Rotor</i>)	°C	-30...85
Nominal temperature range (<i>Stator</i>)	°C	0...80
Operating temperature range (<i>Stator</i>) #9	°C	-20...85
Storage temperature range (<i>Stator</i>)	°C	-30...85
Nominal temperature range (<i>TCU</i>)	°C	0...70
Operating temperature range (<i>TCU</i>)	°C	-20...70
Storage temperature range (<i>TCU</i>)	°C	-30...85

Mechanical shock (EN 60068-2-27)

Quantity	-	1,000
Duration	ms	3
Acceleration	m/s ²	650

Vibration load (EN 60068-2-6)

Frequency	Hz	10...2,000
Duration	min.	150
Acceleration	m/s ²	200

Load limits #10

Limit torque, related to M_{d_n}	%	175
Breaking torque approx., related to M_{d_n}	%	375
Axial limit force	kN	6.90
Lateral limit force	N	2,210.00
Bending limit torque	Nm	54.00

Technical data

Type	-	DF2 dual
Accuracy class	%	±0.04
Rated torque (M_{d_n})	Nm	1,000

Mechanical values		
Torsional stiffness	kNm/rad	363
Angle of twist at M_{d_n}	°	0.158
Axial stiffness	kN/mm	198
Radial stiffness	kN/mm	147
Bending stiffness	kNm/°	1.30
Deflection at axial limit force	mm	<0.05
Additional radial deviation at lateral limit force	mm	<0.02
Parallel deviation at bending limit torque	mm	<0.09
Inherent frequency	Hz	1,220
Balance quality-level (DIN ISO 1949)	-	G2.5
Inertia of rotor	kgm ²	0.0033
Max. limits for relative shaft vibration (peak to peak) #11	µm	$S_{(p-p)} = \frac{9000}{\sqrt{n}}$

Technical data

Type	-	DF2 dual
Accuracy class	%	±0.04
Rated torque (M _{d,n})	Nm	1,000
Weight approx.		
Rotor #12	kg	1.6
Stator (without speed encoder) #12	kg	0.96
Mounting distances (without optional speed detection system)		
Nominal radial displacement (rotor - stator)	mm	149.5
Tolerance to nominal radial displacement (rotor - stator)	mm	+0.2/-0.2
Nominal axial displacement (rotor - stator) #7	mm	7.0
Tolerance to nominal axial displacement (rotor - stator)	mm	±0.5
Flatness and concentricity tolerances rotor		
Circular run-out-axial tolerance #13	mm	0.01
Circular run-out-radial tolerance #13	mm	0.01
Power supply		
Nominal supply	V	(DC) 24
Supply range #14	V	(DC) 23...25
Max. current consumption in measuring mode	A	<1
Max. current consumption in start-up mode	A	<2
Nominal power consumption	W	<24
Load resistance		
Frequency output	-	RS422
Voltage output	kOhm	≥50
Dynamic		
Frequency output	kHz	≤6
Voltage output	kHz	≤6
Current output	kHz	N/A
CAN output conversation rate	1/s	≤2,000

Technical data

Type	-	DF2 dual
Accuracy class	%	±0.04
Rated torque (M_{dn})	Nm	1,000
Miscellaneous		
Protection class (<i>Rotor</i>)	-	IP54
Protection class (<i>Stator</i>)	-	IP54
Protection class (rotor, extended)	-	N/A
Protection class (stator, extended)	-	N/A
Pitch circle screw information	-	8 * M10 (12.9)
CAN bus type	-	2B
Configuration interface	-	Ethernet
Central hole	mm	N/A
Material	-	Steel
Measuring range (related to M_{dn})	%	110
Compatible evaluation units (TCU)	-	TCU5
Stator type	-	DF2 dual
Sales information		
Article number	-	10016142
U.S. FCC certificate	-	No

Remarks and information

Link no.	Topic	Remark
#1	Nominal torque	Based on customer requests, the measurement systems can optionally be optimized for not listed nominal torque values (intermediate ranges possible).
#2	Second torque range	The written second nominal torque value ($M_{d_{ns}}$) is the smallest possible. Greater second torque ranges can be chosen on demand.
#3	Dimensions	Mechanical dimensions are without engagement. Use the drawings and step files as master for your constructions.
#4	Details in the drawings	Value can vary by optional components. Please find details to this attribute in the integrated drawings.
#5	Pitch circle diameter	The pitch circle diameter is identically at input and output side for most systems. More information is given in the drawings of a product.
#6	Linearity	Values of Linearity deviation incl. Hysteresis can only be reached if positive and negative sensitivity values are used.
#7	Reference planes	Please check the drawings for information about the reference planes of this attribute.
#8	Temperature range (rotor)	No condensation allowed.
#9	Temperature range (stator)	No condensation allowed. Temperature related to housing ground point.
#10	Load limits	The given values are only valid if no other load occurs at the same time. If the loads in sum are 100%, the max. error will be 0.3% of the nominal torque. Limit and break torque are lower if other loads are applied (such as lateral forces).

Remarks and information

Link no.	Topic	Remark
#11	Vibration limits	Vibration limits are not an influence to the machine. They reflect the allowed effect onto the rotor (ISO 7919-3). Parameter "n" is given in "r/min".
#12	Weights	Weights are related to components without options like speed detection system. Please contact us for exact weight information of options.
#13	Flatness and concentricity tolerances	The parameters of "Flatness and concentricity tolerances rotor" are manufacturing tolerances.
#14	Supply voltage	The supply voltage range must be given at measurement system side. Long wires can reduce the voltage level from power supply to measurement system.

Drawing

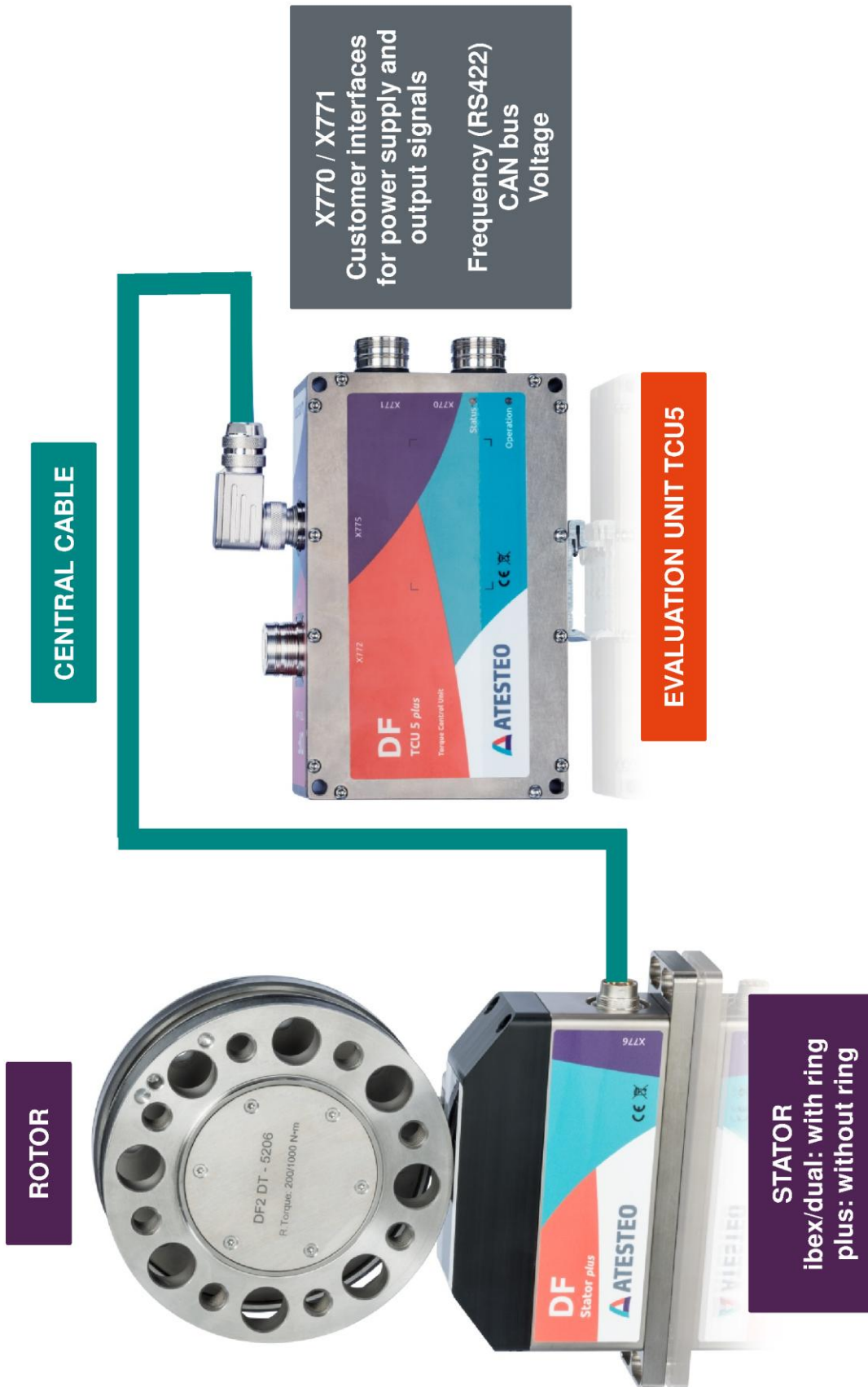

Drawing

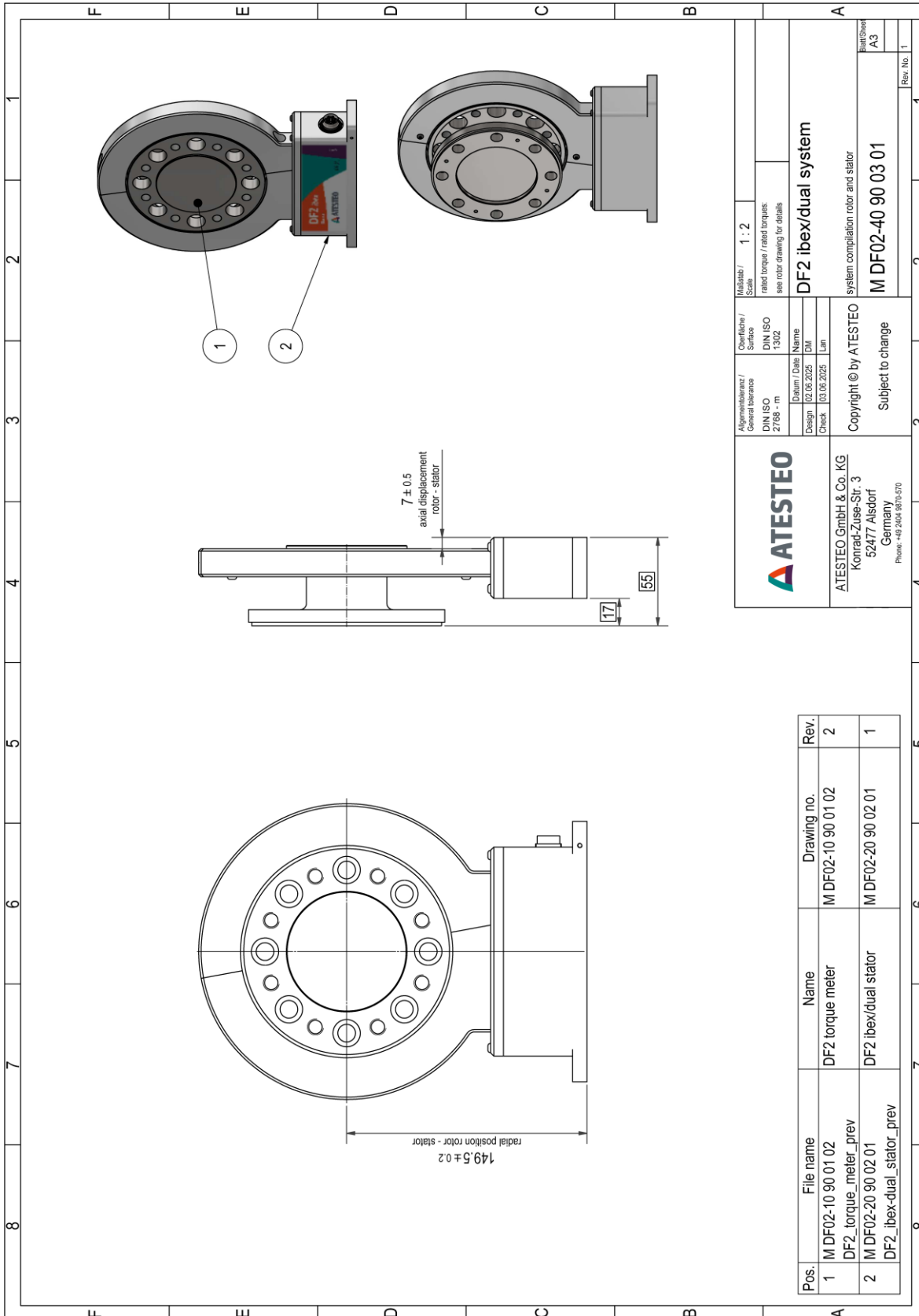

Drawing

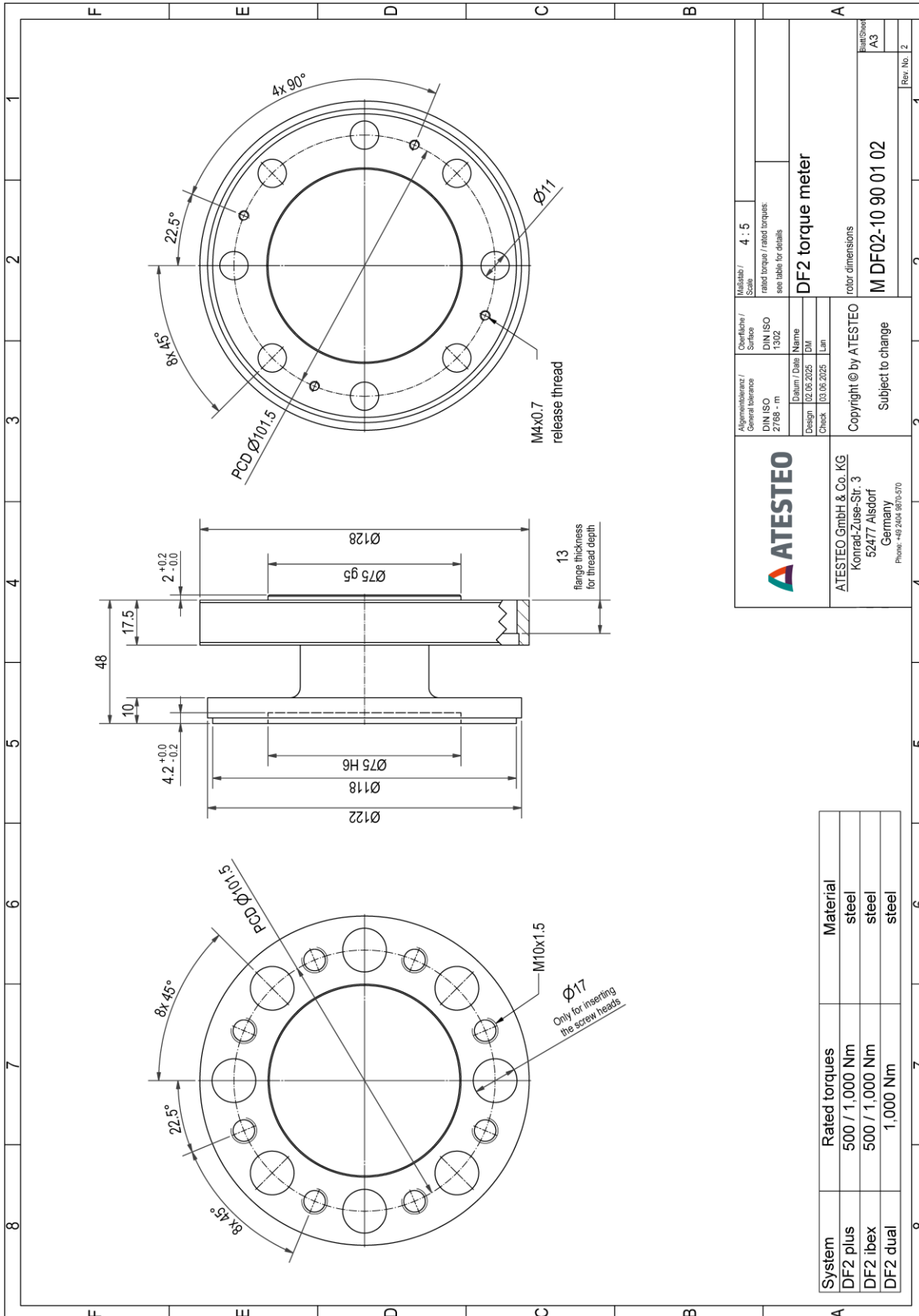

Drawing

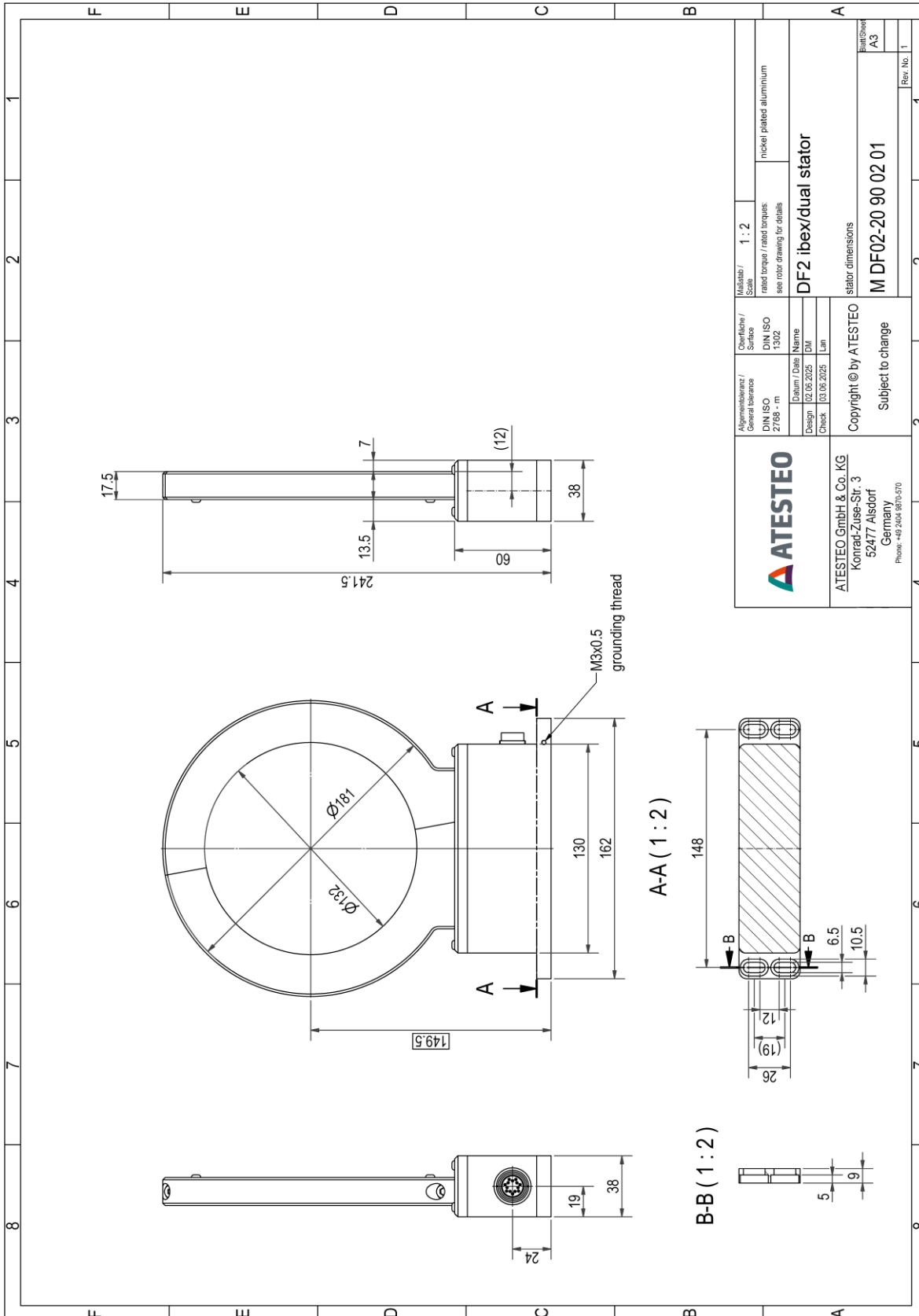

ATESTEO		ATESTEO GmbH & Co. KG Konrad-Zuse-Str. 3 52477 Alsdorf Germany Phone: +49 2404 9800-570		Copyright © by ATESTEO Subject to change		Copyright © by ATESTEO Subject to change	
Allgemeinbezeichnung / General bezeichnung DIN ISO 2768 - m		Oberfläche / Surface DIN ISO 1302		Multiplikator / Scale 1 : 2		Material / Material nickel plated aluminium	
Datum / Date 02.06.2025		Name DLI		DF2 ibex/dual stator		Stator dimensions	
Design 03.06.2025		Lan		M DF02-20 90 02 01		Blatt/Sheet A3	
						Rev. No. 1	

DF2 dual SPD_MGN System

DF2 dual

Drawing

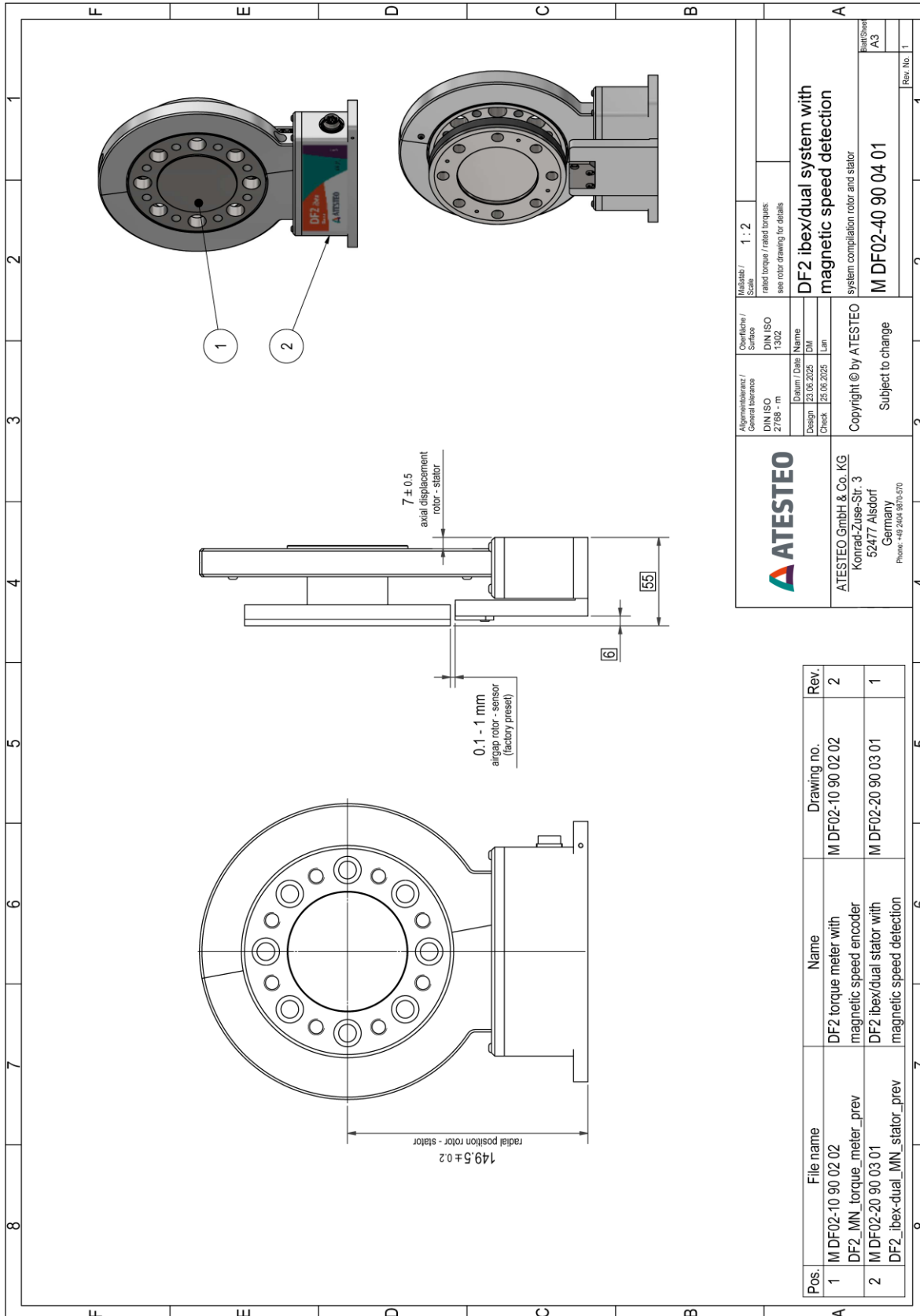

Pos.	File name	Name	Drawing no.	Rev.
1	M DF02-10 90 02 02	DF2 torque meter with magnetic speed encoder	M DF02-10 90 02 02	2
2	M DF02-20 90 03 01	DF2 ibex/dual stator with magnetic speed detection	M DF02-20 90 03 01	1

		ATESTEO Konrad-Zuse-Str. 3 52477 Aisdorf Germany Phone: +49 2404 9800-570	
Allgemeintoleranz / General tolerance DIN ISO 2768 - m	Oberflächen / Surface DIN ISO 1302	Multiplikator / Scale 1 : 2	ratted torque / rated torques: see rotor drawing for details
Datum / Date 25.06.2025	Name Lan	DF2 ibex/dual system with magnetic speed detection system compilation rotor and stator M DF02-40 90 04 01	
Copyright © by ATESTEO Subject to change		Blatt/Sheet A3	Rev. No. 1

DF2 dual SPD_MGN Rotor

DF2 dual

Drawing

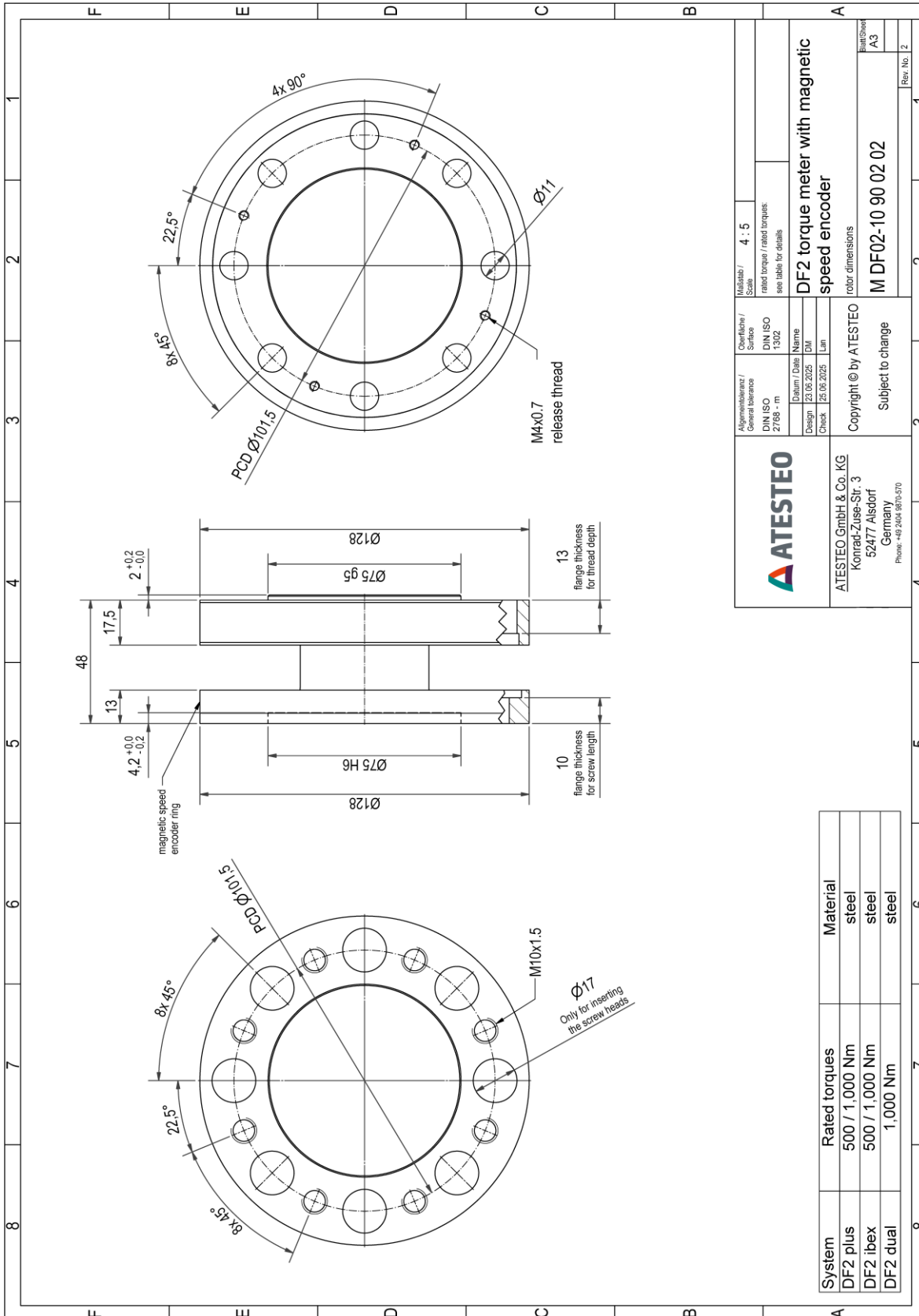

ATESTEO		ATESTEO GmbH & Co. KG Konrad-Zuse-Str. 3 52477 Aisdorf Germany Phone: +49 2404 9870-570	
Abgleichwertigkeit / General tolerance DIN ISO 2768 - m	Charakteristik / Surface DIN ISO 1302	Multiplikator / Scale 4 : 5	DF2 torque meter with magnetic speed encoder
Design 23.06.2025	Checked 25.06.2025	rotor dimensions M DF02-10 90 02 02	DF2 torque meter with magnetic speed encoder
Copyright © by ATESTEO Subject to change		Blatt/Sheet A3	
		Rev. No. 2	

System	Rated torques	Material
DF2 plus	500 / 1,000 Nm	steel
DF2 ibex	500 / 1,000 Nm	steel
DF2 dual	1,000 Nm	steel

DF2 dual SPD_MGN Stator

DF2 dual

Drawing

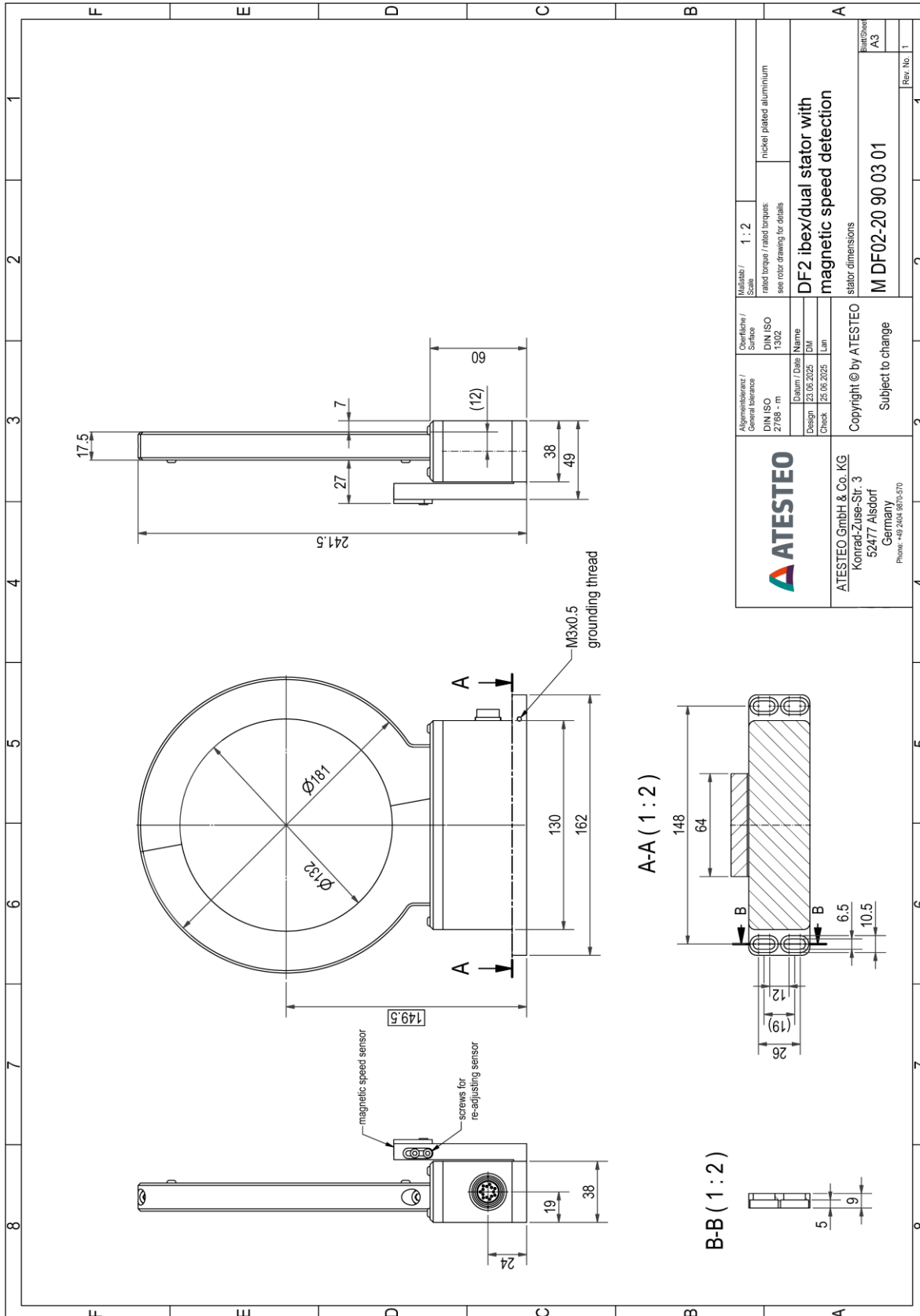

©2026, ATESTEO GmbH & Co. KG, This product data sheet was created on 01.23.2026.

The information contained in the product data sheet corresponds to the status quo at the time the document was created. ATESTEO continually further develops its products and reserves the right to make changes to the technical data. ATESTEO does not accept any liability for consequential losses arising from the use of this product data sheet or the information contained therein.

Drawing

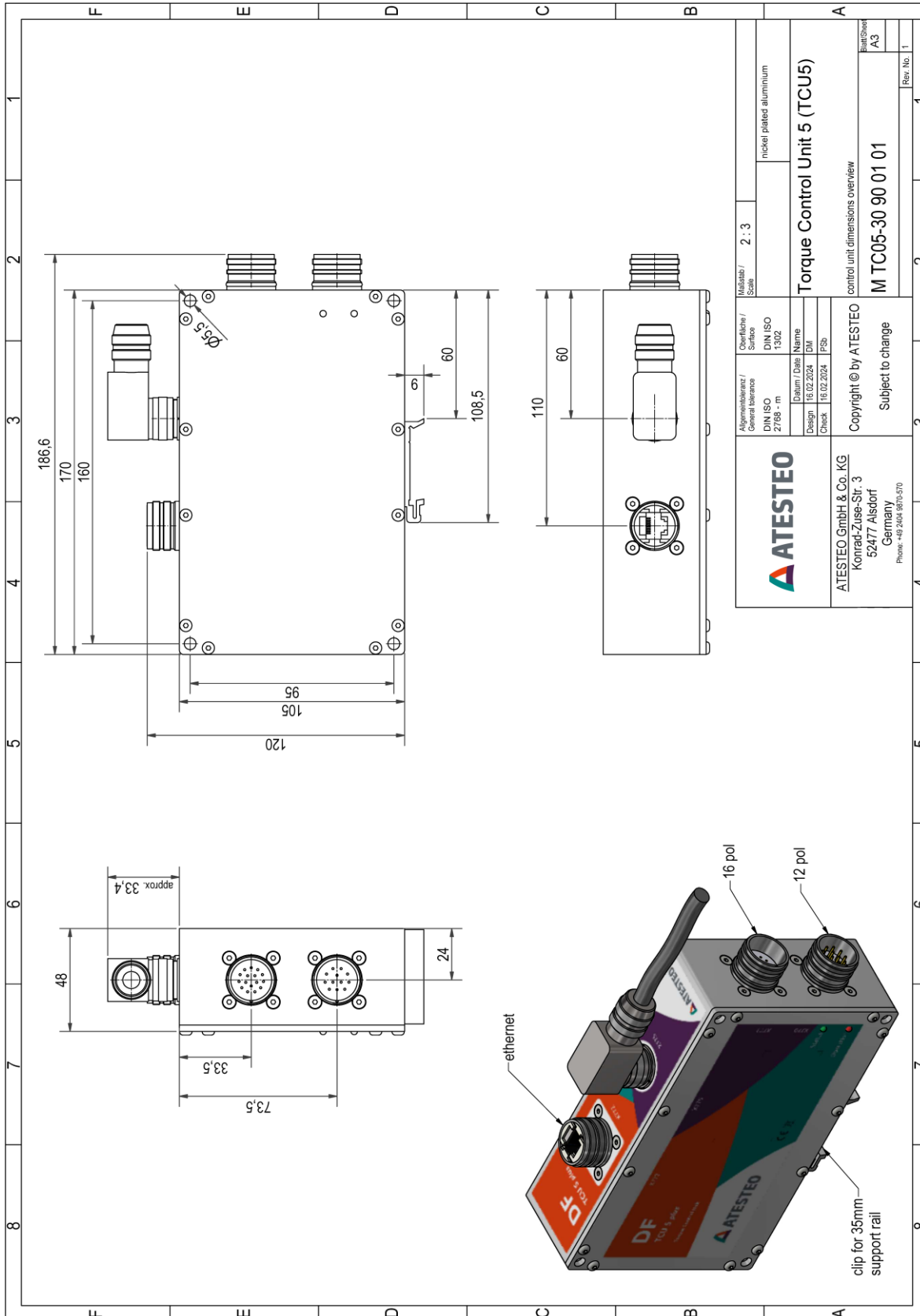

Would you like to learn more about our products, solutions, and services in the area of measuring systems, vehicle equipment, and actuators? Just call us at +49 (0) 2404 9870 570 or send email to equipment@atesteo.com. Your personal ATESTEO contact would be pleased to assist you.

ATESTEO GmbH & Co. KG
Konrad-Zuse-Straße 3
52477 Alsdorf
Germany

Phone +49 (0) 2404 9870 - 0
Email info@atesteo.com

<https://www.atesteo.com/en/>