



Manual F series, T series, RT11 series, HSTT series

Manual F series, T series, RT11 series, HSTT series

Version V1.4

Your contact for service requests

ATESTEO GmbH & Co. KG
Konrad-Zuse-Straße 3
52477 Alsdorf
Germany

Phone +49 (0) 2404 9870-580
E-Mail service-pm@atesteo.com
www.atesteo.com

1	INTRODUCTION.....	8
1.1	MANUFACTURER	9
1.2	CHANGE LOG (MANUAL).....	9
1.3	SCOPE OF APPLICATION.....	10
1.4	DISPOSAL AND ENVIRONMENT	11
1.5	PARTS LIST	12
1.5.1	<i>Part list F0iS to F6iS</i>	12
1.5.2	<i>Part list F0eS toF6eS</i>	12
1.5.3	<i>Part list TiS Z / SiS Z</i>	13
1.5.4	<i>Part list TeS Z / SeS Z</i>	13
1.5.5	<i>Part list RT1eS / RT11eS</i>	13
1.5.6	<i>Part list HSTT1eS/HSTT2eS</i>	13
2	SAFETY INSTRUCTIONS.....	14
2.1	GENERAL SAFETY INSTRUCTIONS	14
2.2	EXPLANATION OF SYMBOLS AND NOTICE	15
2.3	INTENDED USE	16
2.4	MODIFICATIONS / CONVERSIONS	16
2.5	RESPONSIBILITY OF THE OPERATOR	16
2.6	TRANSPORT AND STORAGE	19
2.7	SAFETY NOTES FOR ASSEMBLY	19
2.8	SAFETY NOTES FOR OPERATION	20
2.9	LOAD LIMITS.....	20
3	SYSTEM DESCRIPTION.....	22
3.1	TYPE IS	22
3.2	TYPE ES.....	22
3.3	TECHNICAL DATA	23
3.4	TELEMETRY AND MEASUREMENT RANGES	24
3.4.1	<i>One-channel telemetry (FM)</i>	25
3.4.2	<i>Second channel (DT2)</i>	25
3.4.3	<i>Dual range telemetry (DT)</i>	27
3.4.4	<i>Changing the measuring range</i>	28

3.4.5	<i>Compatibilities</i>	28
3.5	FUNCTIONS	30
3.5.1	<i>Self-test</i>	30
3.5.2	<i>Zero adjustment</i>	30
3.5.3	<i>Test signal</i>	30
3.5.4	<i>Supply search process</i>	30
3.5.5	<i>Alerts</i>	31
3.6	SPEED DETECTION SYSTEMS	31
3.6.1	<i>Inductive speed detection</i>	31
3.6.2	<i>Magnetic speed detection</i>	32
3.6.3	<i>Optical speed detection</i>	33
3.7	TEST REPORT AND CALIBRATION SHEETS	33
3.7.1	<i>Factory calibration sheet</i>	35
3.7.2	<i>DAkkS calibration sheet</i>	36
3.8	LED CODES	37
3.8.1	<i>Green LED</i>	37
3.8.2	<i>Red LED</i>	37
4	MECHANICAL INSTALLATION	38
4.1	TRANSPORT	38
4.2	LIFTING THE ROTOR	38
4.3	STATOR INSTALLATION	39
4.3.1	<i>Alignment</i>	40
4.3.2	<i>iS Stator</i>	40
4.3.2.1	<i>Connecting to a machine</i>	40
4.3.2.2	<i>Foot mounting</i>	41
4.3.3	<i>eS Stator</i>	42
4.4	ROTOR INSTALLATION	43
4.4.1	<i>Recommended tightening torques</i>	44
4.4.1.1	<i>FxiS / FxeS</i>	44
4.4.1.2	<i>TxS / SxS</i>	47
4.4.1.3	<i>RT1eS (steel) & RT11eS (titanium)</i>	48
4.4.1.4	<i>HSTTeS</i>	50

4.5	INSTALLATION OF SPEED DETECTION SYSTEMS.....	51
4.5.1	<i>Installation of inductive speed detection</i>	51
4.5.2	<i>Installation of magnetic speed detection</i>	51
4.5.3	<i>Installation of optical speed detection</i>	52
4.6	INSTALLATION OF THE EVALUATION UNIT (TCU2).....	56
5	ELECTRICAL INSTALLATION.....	57
5.1	CONNECTION TO MAINS.....	57
5.2	CONNECTING TORQUE METER/EVALUATION UNIT WITH THE DATA ACQUISITION SYSTEM.....	57
5.3	ANALOGUE OUTPUTS.....	58
5.3.1	<i>Output A (Voltage)</i>	58
5.3.2	<i>Output B (Voltage)</i>	58
5.3.3	<i>Output C (State)</i>	58
5.3.4	<i>MDI (Current output)</i>	59
5.4	DIGITAL INPUTS/OUTPUTS.....	60
5.4.1	<i>Input “control signals”</i>	60
5.4.1.1	Self-test.....	60
5.4.1.2	Zero adjustment.....	60
5.4.1.3	Test signal.....	60
5.4.2	<i>Digital Alerts</i>	60
5.4.2.1	Alert Md/N.....	60
5.4.2.2	Alert IR.....	61
5.4.2.3	Reset alerts.....	61
5.5	PIN ASSIGNMENTS IS AND ES TYPE.....	61
5.5.1	<i>Connector X750</i>	62
5.5.2	<i>Connector X751/X752</i>	64
5.6	ELECTRICAL CIRCUITS.....	65
5.6.1	<i>RS422 outputs</i>	65
5.6.2	<i>Alert outputs</i>	66
5.6.3	<i>Alert reset input</i>	66
5.6.4	<i>Control input</i>	67
5.6.5	<i>Analogue output A/B (Voltage)</i>	67

5.6.6	<i>Analogue output C (Voltage)</i>	67
5.6.7	<i>Current output (MDI)</i>	68
5.6.8	<i>RS232</i>	68
5.6.9	<i>CAN</i>	69
6	FIRST INSTALLATION	70
6.1	INITIAL INSTALLATION	70
6.2	REPLACING THE TORQUE METER	70
7	CONFIGURATION	71
7.1	SOFTWARE TCUCONFIG	71
7.1.1	<i>Setup inductive power supply</i>	73
7.1.2	<i>Torque zero adjustment</i>	73
7.1.3	<i>Test signal</i>	73
7.1.4	<i>Setup of the calibration parameters</i>	74
7.1.5	<i>Setup analogue output</i>	75
7.1.6	<i>Setup current output</i>	76
7.1.7	<i>Setup filter</i>	77
7.1.8	<i>Setup alarm</i>	78
7.1.9	<i>Setup CAN interface</i>	79
7.2	TERMINAL PROGRAM	82
7.2.1	<i>Main Menu</i>	82
7.2.2	<i>Filter settings</i>	84
7.2.3	<i>Alarm settings</i>	86
7.2.4	<i>Output settings</i>	86
7.2.5	<i>Torque meter settings</i>	88
7.2.5.1	<i>Setting the calibration parameters</i>	91
7.2.5.2	<i>Supply search process</i>	91
7.2.5.3	<i>Zero adjustment</i>	91
7.2.6	<i>Read parameters</i>	91
7.2.7	<i>Self-test</i>	93
7.2.8	<i>Analogue setup</i>	93
7.2.9	<i>CAN setup</i>	95

7.3	CAN BUS.....	96
8	GENERAL INFORMATION	102
8.1	OVERVOLTAGE PROTECTION.....	102
8.2	TORQUE METER WITHOUT TEST SIGNAL	102
8.3	CALIBRATION	102
8.4	SERVICE HOTLINE.....	103
8.5	RECOMMENDATIONS FOR THE ZERO-POINT ADJUSTMENT.....	103
8.5.1	<i>Thermal ical influences</i>	103
8.5.2	<i>Hysteresis-related influences</i>	104
8.5.3	<i>Ageing</i>	105
8.5.4	<i>Influence of lateral forces</i>	105
8.5.5	<i>General</i>	105
9	APPENDIX.....	107
9.1	SPECIAL DT2 FUNCTIONS	107
9.1.1	<i>Channel selection by using an external signal</i>	107
9.1.2	<i>Channel selection by using a terminal program</i>	109
9.1.3	<i>Channel selection by using the CAN interface</i>	111
9.2	LIST OF IMAGES.....	115
9.3	LIST OF TABLES.....	117
9.4	MANUFACTURER'S DECLARATION:	118

1 Introduction

Thank you for choosing an ATESTEO GmbH & Co. KG quality product. Please read the system description carefully so you make the most of the versatile features of your product.

These operating instructions are an integral part of the F series and all derivatives of the F series (see 1.3) and should always be carefully kept with the F series until it is disposed of.

It is impossible to eliminate every danger to people and/or material that the F series might present. For this reason, every person working at the F series or is involved in its transport, setting up, control, maintenance or repair must be properly instructed and be informed of the possible dangers.

For this purpose, the operating instructions and, especially, the safety instructions must be carefully read, understood and observed.

Company ATESTEO GmbH & Co. KG reserves the right to carry out changes to its products which serve the technical further development the company ATESTEO GmbH & Co. KG. These changes aren't documented expressly in every individual case.

This operating instructions and the information contained in it were compiled with the advisable care.

However, ATESTEO accepts no liability for printing errors or other errors and damage that may result for ATESTEO.

The brands mentioned in this operator's manual and product names are trademarks or registered trademarks of the respective title holders. Please do not miss contacting us if there is anything in the operating instructions that you cannot clearly understand. We are grateful for any kind of suggestion or criticism that you may wish to make; please let us know or write to us. This will help us to make the operating instruction still more user-friendly in taking account of your wishes and requirements.

1.1 Manufacturer

ATESTEO GmbH & Co. KG
Konrad-Zuse-Straße 3
52477 Alsdorf
Germany

Phone: +49 (0) 2404 9870-570

info@atesteo.com
www.atesteo.com

1.2 Change log (manual)

V1.4 22.05.2026

- RT11eS (titanium) added
- Cable colour for pin 15 of X751/X752 corrected

V1.3 04.09.2025

- “Grounding scheme” visually optimized
- Technical data aligned to data sheets
- Screw-in depth defined
- Product F34xS added

V1.2 11.07.2025

- First completely reworked version incl. change log
- Removed discontinued products F1i/F2i
- List of product names reworked
- Description about system functions added
- Separation between mechanics, electrics and configuration improved
- Reworked format
- List of tightening torques added
- Remark to disconnect RS232 in operation added

1.3 Scope of application

In this manual you will find all steps which are necessary to start-up the ATESTEO torque and speed measurement system.

This manual is usable for the following types of torque meters:

- Torque meter F0iS/F1iS/F2iS/F23iS/F3iS/F34iS/F4iS/F5iS/F6iS
- Torque meter F0eS/F1eS/F2eS/F23eS/F3eS/F34eS/F4eS/F5eS/F6eS
- Torque meter F0iS-HS/F0eS-HS
- Torque meter F0iS-SV/F0eS-SV
- Torque meter RT1eS and RT11eS and all variants of it
- Torque meter TiS/TeS Z50
- Torque meter SiS/SeS Z50
- Torque meter HSTT1eS/HSTT2eS
- Torque meter FLM1iS (F0iS) / FLM1eS (F0eS)
- Customized torque meters which are based on F series. Those torque meters usually have an additional manual.

All measurement systems work contactless and are maintenance-free. The data transmission is realized by a frequency modulated infrared transmitter. The power of the rotating electronic module works inductive.

The system FLFM1iS is only named F0iS in this document since they are technical the same.

The system FLFM1eS is only named F0eS in this document since they are technical the same.

Information

With this product, you received an information sheet with the default settings.

1.4 Disposal and environment

Electrical and electronic products are subject to special conditions for disposal. Proper disposal of old equipment prevents health hazards and environmental damage.

Packaging

The original packaging of ATESTEO equipment can be recycled, as it is made of recyclable material. However, you should keep the packaging for at least the warranty period. In the event of a complaint, the torque flange, as well as the accessories, must be returned in the original packaging.

For ecological reasons, the empty packaging should not be returned.

Legally prescribed labelling for disposal



Electrical and electronic devices bearing the symbol  are subject to the European Directive 2002/96 / EC on waste electrical and electronic equipment. The symbol indicates that waste equipment that is no longer usable must be disposed of separately from regular household waste in

accordance with European environmental protection and recycling regulations.

However, the disposal regulations vary from country to country, which is why we ask you, if necessary, your supplier how to dispose of your waste.

1.5 Parts list

1.5.1 Part list F0iS to F6iS

The complete system comes with:

- Torque meter (rotor)
- Stator type iS (evaluation unit inside of a housing fixed at the stator ring)
- Male connector with 16 pins (data cable optional)
- Female connector with 12 pins (central cable optional)
- Test report (with sensitivity and test signal values)
- Options according to purchase order: e. g. Calibration certificate (DAkkS or factory standard), speed detection system, ...

1.5.2 Part list F0eS to F6eS

The complete system comes with:

- Torque meter (rotor)
- Stator type eS (stator ring incl. cables to TCU2)
- TCU2 («Torque Control Unit», external evaluation unit)
- Male connector with 16 pins (data cable optional)
- Female connector with 12 pins (central cable optional)
- Test report (with sensitivity and test signal values)

- Options according to purchase order: e. g. Calibration certificate (DAkkS or factory standard), speed detection system, ...

1.5.3 Part list TiS Z / SiS Z

See 1.5.1

1.5.4 Part list TeS Z / SeS Z

See 1.5.2

1.5.5 Part list RT1eS / RT11eS

See 1.5.2

1.5.6 Part list HSTT1eS/HSTT2eS

See 1.5.2

2 Safety Instructions

2.1 General safety instructions

The manual must be read carefully before starting up, maintenance work or any other work on the torque measuring system. The prerequisite for the safe and proper handling of the equipment knows all safety instructions and safety regulations of the attachment.

Every safeguard needs to be correctly mounted and fully functional before any start-up.

Shafts or adapters mounted to the torque meter must be properly designed, so that critical bending moment is avoided.

Exclusively qualified laborers are allowed to do maintenance work on any electrical components (see paragraph “Qualified personnel”).

If the torque meter is sold on, these safety instructions must be included.

Note on additional standards:



Low Voltage Directive 73/23/EWG, Electromagnetic Compatibility Directive 89/336/EWG and the harmonized standards



DIN EN 292-1 Safety of machinery



DIN EN 292-2 Safety of machinery



Maintenance and inspections on the electrical equipment are to be carried out by trained personnel. Non-designated use and modifications of the measurement system will make the EC declaration invalid.

2.2 Explanation of symbols and notice

Warnings

Warnings are indicated by symbols in these safety instructions.

Signal words are introduced, which express the extent of the hazard. It is imperative that you follow the instructions and act with care to avoid accidents, personal injury and material damage.



Information

Draws attention to important information about correct handling.



Caution

Warns of a potentially dangerous situation in which failure to comply with safety requirements can result in slight or moderate physical injury.

2.3 Intended use

The torque meter is highly accurate and resistant to rotational speed. The signals from the flange serve to control the test bench and to analyze the components.

The torque flange is used just for torque measurement tasks within the load limits in the specification (see separate data sheet and 3.3). Any other use is not permitted.



The torque meter is not allowed for use as a safety component.



Note

Stator operation is only permitted if the rotor is installed as described in the mounting instruction.

2.4 Modifications / conversions

Any modifications / conversions of the design or safety engineering of the torque meter without the explicit agreement from ATESTEO will lead to the loss of warranty or liability. Any damages or injuries of personnel therefrom are in responsibility of the operator.

2.5 Responsibility of the operator

Standards

The ATESTEO torque meter was designed and constructed taking account of a risk analysis and careful selection of harmonized standards and other technical specifications with which it complies. It represents the state of the art and guarantees a maximum degree of safety.

Qualified personnel

Qualified personnel are persons who by reason of their training, experience, instruction and their knowledge of the relevant standards, regulations, accident prevention rules and working conditions have been authorized by the person responsible for the safety of the machine/product to perform the appropriate activities required, and thereby are able to recognize and prevent potentially dangerous situations (For the definition of skilled workers see VDE 0 105 or IEC 364, which also regulate the prohibition of the employment of unqualified persons). Knowledge of first aid and the local rescue organization must also be available.

Transportation, assembly, installation, commissioning, maintenance, and repair will be performed by qualified personnel or controlled by responsible skilled hands.

Safety relevant disconnecting device

The torque meter cannot implement any safety relevant cut-offs. It is in the operator's responsibility to integrate the torque meter into superior safety system.

The electrical conditioning the measurement signal should be designed so that measurement signal failure does not subsequently cause damage.

Residual risks

The power and scope of delivery of the torque meter covers only a subset of the torque measurement technology. Safety aspects of torque measurement technology must be planned, implemented and taken into account by the system planner, supplier or operator in such a way that residual risks are minimized. Each existing regulations must be observed. Attention should be drawn to residual risks associated with torque measuring technology.

In the case of a shaft break, you must ensure that there is no risk of injury. This should be done with a shaft protection cover in a closed test room

with corresponding security doors. During operation, no person should stay in the test room.

Usage recommendations for personal protective equipment



Working in a workshop generally requires wearing safety shoes.



Use suitable gloves when handling corrosive or irritating solutions and adhesives.

2.6 Transport and storage

Check the delivery immediately for completeness and shipping damage.

Use working gloves during transport/ assembly/ maintenance.



Storage

- Do not store outdoors
- Store dry and dust-free
- Do not expose to aggressive media
- Protect from sunlight
- Avoid mechanical shocks
- Storage temperature according data sheet

If stored for more than 3 months, regularly check the general condition of all parts and packaging.

2.7 Safety notes for assembly



Tightening torque

When tightening the screws, the specified tightening torques (see 4.4.1) must be observed.



Electric wire

All cables must be professionally laid according to the actual standards.



Rotating parts

Rotating parts must be earthed - risk of static electricity.

2.8 Safety notes for operation

As accident prevention a covering must be fitted once the torque meters have been mounted. This is the fact whether the torque meter is already fully protected by the design of the machine or by existing safety precautions. Please pay attention to the following requirements for the covering as accident prevention:

- The covering must not be free to rotate.
- Covering must be positioned at a suitable distance or be so arranged that there is no access to any moving parts within.
- Covering should prevent squeezing or shearing and provide sufficient protection against parts that might come loose.
- Covering must still be attached even if the moving parts of the torque flange are installed outside people's movement and working range.



Note

Improper use and handling as well as constructional changes will invalidate the EC declaration of conformity.

2.9 Load limits

Observe technical data sheets when using the torque meter. Pay particular attention to never exceed the respective maximum loads. For example:

- Load limits,
- Torque oscillation width,
- Temperature limits,

- Longitudinal limit force, lateral limit force or limit bending moment,
- Limits of electrical load-carrying capacity,
- Limit rotation speed.

3 System description

The F series torque measurement systems represent a complete generation of torque meters with an evaluation unit. Except for a 24 VDC power supply, no external components are required for operation. High-end temperature compensation guarantees very good stability and repeatability of the output signals. Some models are equipped with an inductive one-track speed measurement system.

3.1 Type iS

Stator type iS provides functionality in compact way. The evaluation electronic is integrated in the stator housing below the stator ring.

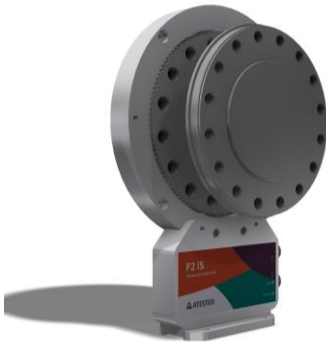

Figure 3-1: Example of iS type with image of F2iS

3.2 Type eS

The stator type eS allows operation under extended temperature range or confined installation space. The electronic of the evaluation unit is placed in a separate housing (TCU2). Stator ring and TCU2 are connected with 1.5 m long cables.

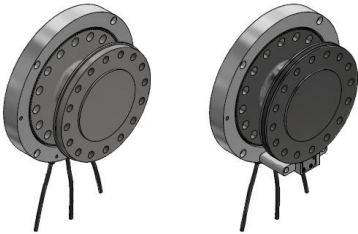

Figure 3-2: Example of eS type with image of F2eS



Figure 3-3: Example of evaluation unit TCU2

3.3 Technical Data

Parameter	Value
Power supply	24V DC max. 2A
Dynamic of frequency output (torque signal)	≤ 7 kHz
Dynamic of voltage output (torque signal)	≤ 1 kHz
Lowest Frequency, which can be measured (speed signal)	5Hz (the output for frequencies < 5 Hz is 0Hz)
Voltage output range	selectable 0...5V, 0...10V, -5...+5V, -10...+10V

Voltage output signal resolution	16 bit
Voltage output impedance	50 Ohm
Optional current output (torque)	selectable 4...20mA, 0...20mA
Maximum permissible speed	This parameter depends on the system and each option (e.g. speed detection system). The exact value is defined on the type label.
Filter	<i>Torque</i> : 1st-order IIR-Filter with 6 fixed cut-off frequencies <i>Speed</i> : Moving Average with adjustable filter depth
CAN Interface	CAN2B Identifier free adjustable max. 1MBaud max. 1,000 messages/channel/second
Serial port	RS232, 19,200 Baud, 8 Data Bit, No Parity Bit, 1 Stop Bit, No Protocol
Frequency outputs	RS422 Torque Inductive speed sensor Magnetic speed sensor (optional) Optical speed sensor (optional)

Table 3-1: Technical data

3.4 Telemetry and measurement ranges

The torque meter can be optionally equipped with different telemetry systems and measurement ranges.

Telemetry and measurement range type	Number of measurement ranges	Number of telemetry channels
--------------------------------------	------------------------------	------------------------------

One channel telemetry (FM)	1	1
DT2 (second measurement range)	2	1
DT (Dual telemetry)	2	2

Table 3-2: Overview about telemetry systems and measurement ranges

3.4.1 One-channel telemetry (FM)

Functions:

- Frequency output proportional to torque 60 kHz \pm 20 kHz
- Frequency output proportional to speed
- Voltage output [V] proportional to torque with 1,000 readings/s
- Voltage output [V] proportional to speed
- Test signal
- Zero adjustment
- System parameters via RS232
- CAN 2B interface

3.4.2 Second channel (DT2)

The entire system can be equipped with a second amplifier during production. This second amplifier amplifies the signal from the strain gauge with a very high degree of accuracy. The result is a second measuring range in which small torques can be measured accurately. This eliminates the need to frequently change the torque sensors to accurately measure small torques. The second measuring range also includes temperature compensation and a test signal like the first measuring range (see Figure 3-4). **With the DT2 variant, only one measuring range can be transmitted at a time.**



To utilise the full measuring accuracy of the small measuring range, please refer to 3.4.4.

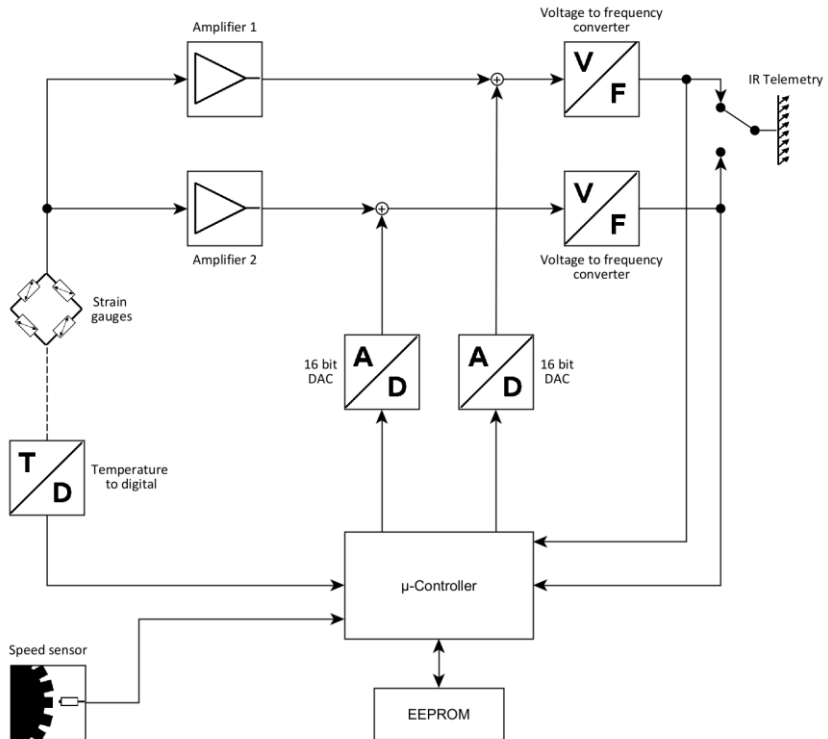

Figure 3-4: DT2 variant

Functions:

- 2 x frequency output proportional to the torque 60 kHz± 20 kHz (parallel transmission of the two measuring ranges is not possible)
- Frequency output proportional to speed

- Analogue output [V] proportional to the torque with 1,000 readings/s
- Analogue output [V] proportional to speed
- Test signal
- Zero adjustment
- System parameters via RS232
- CAN interface (2B)
- DT2 with switchover option between the two channels

3.4.3 Dual range telemetry (DT)

The systems with optional dual telemetry have a second amplifier like the DT2 systems but are also equipped with a second infrared transmission.

With the double telemetry system (DT), it is possible to measure both high and low torques with a high degree of accuracy using one torque meter.

Functions:

- 2 x frequency output proportional to the torque 60 kHz \pm 20 kHz
- Frequency output proportional to speed
- Analogue output [V] proportional to the torque with 1,000 readings/s
- Analogue output [V] proportional to speed
- Test signal
- Zero adjustment
- System parameters via RS232
- CAN interface (2B)
- DT for parallel use of two measuring ranges



To utilise the full measuring accuracy of the small measuring range, please refer to 3.4.4.

3.4.4 Changing the measuring range

The second measuring range of a DT2/DT flange is provided to solve measurement tasks where a sensor replacement or test bench conversion is not possible or permitted. This allows lower torques to still be measured accurately with the second measuring range. Parasitic influences such as bending moment and lateral force have a greater impact on the measurement error of the second channel. The measuring range should be selected depending on the measurement cycle and before it starts and should not be changed during the cycle.

When changing the measuring range, hysteresis-related influences must be taken into account. Important details are described in Chapter 8.5.2.

3.4.5 Compatibilities

Measuring system	Single-channel telemetry	Second measuring range (DT2)	Double telemetry (DT)
FxiS	Yes	Yes, optional	On request
FxeS	Yes	Yes, optional	On request
TiS Z / TeS Z / SiS Z / SeS Z	Yes	Yes, optional	No
RT1eS / RT11eS	Yes	Yes, optional	No
HSTT1eS / HSTT2eS	Yes	Yes, optional	No

Table 3-3: Availability of multi-channel telemetry / second measuring range

3.5 Functions

3.5.1 Self-test

The self-test is a test procedure that checks most of the functions of the measuring system. The following settings are checked:

- Setting the supply voltage
- Checking the stored serial number with the torque meter serial number. If the serial numbers are different, the characteristic values for the connected measuring system are automatically adopted.
- Check whether the applied operating point for the supply voltage is stable.

3.5.2 Zero adjustment

During zero-point adjustment, the currently measured torque is saved as the new zero value. Please be sure to read the notes on this at 8.5.

3.5.3 Test signal

The test signal generates an offset at each system output regardless of the measurement results already entered. The level of the test signal is specified on the test report. The test signal is present at all outputs. The signal is generated by an offset jump at the first amplifier of the measuring chain in the rotor and transmitted from there to the evaluation unit as a raw measured value.

3.5.4 Supply search process

The electronics for measuring and transmitting the torque are located in the measuring flange. These electronics are supplied with a reference

voltage of 10V. A voltage search increases the voltage step by step until the output frequency reaches the value of the test signal (also known as the calibration jump) in the test report. The voltage search may only be started in an unloaded system (no torque). At the end of the search process, the automatic adjustment is completed and the system is reset to the operating voltage, which refers to an output frequency of approx. 60 kHz. For good voltage stability, the input voltage of the rotor should be around 15 V.

3.5.5 Alerts

It is important that the maximum safe operating conditions specified for the torque measuring device are observed. Not only to prevent damage to the rotor due to dangerous operating conditions, but also to protect the test bench from damage.

Alarm thresholds can be set for the maximum permissible torque and the maximum permissible speed. The alarm signal is output via open collector outputs on the 16-pin connector X751/X752 and as CAN messages. Circuit details and circuit examples can be found in the chapter 5.

3.6 Speed detection systems

Each speed measurement system has a specific number of pulses per revolution. The exact number depends on the rotor size and, if applicable, on the order details. The available number of pulses can be found on the nameplate and on the test report.

3.6.1 Inductive speed detection

The inductive speed sensor is equipped as standard for some torque meter. It supplies one track with X increments per revolution at the rotor (teeth). The sensor is located at the inner side of the stator ring.

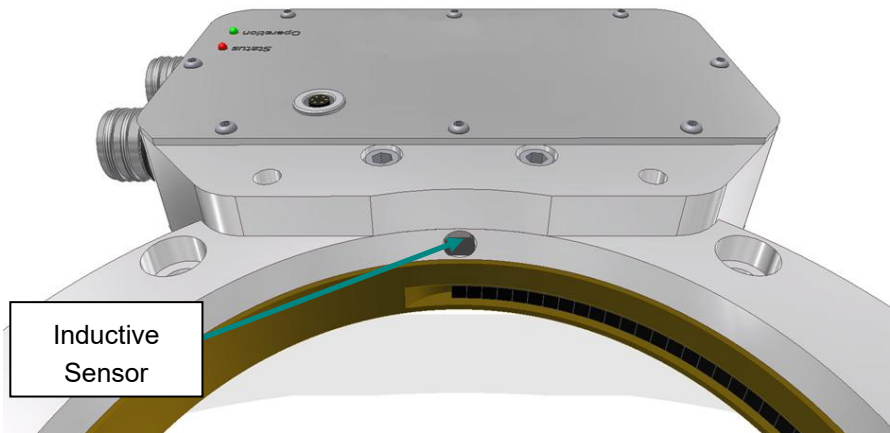

Figure 3-5: Inductive sensor

The speed sensor signals are provided as RS422 signals and as processed values for the analogue outputs and CAN messages.

3.6.2 Magnetic speed detection

The magnetic speed sensor is available as an optional high-resolution speed acquisition providing two tracks with X increments per revolution and a 90° phase shift, thus giving the capability for detecting the rotational direction. It is located on a mounting bracket placed above the electronic compartment. The magnetic speed sensor consists of a sensor module which is connected via a 7 pole connector to the stator electronics.

The speed sensor signals are provided as RS422 signals and as processed values for the analogue outputs and CAN messages. The inductive speed detection cannot be used at the same time with the magnetic speed detection. The speed detection system can be selected in the configuration.

3.6.3 Optical speed detection

The optical speed sensor is available as an optional high-resolution speed acquisition providing two tracks with X impulses per revolution and a 90° phase shift, thus giving the capability for detecting the rotational direction. It is located at the inner side of the stator-ring.

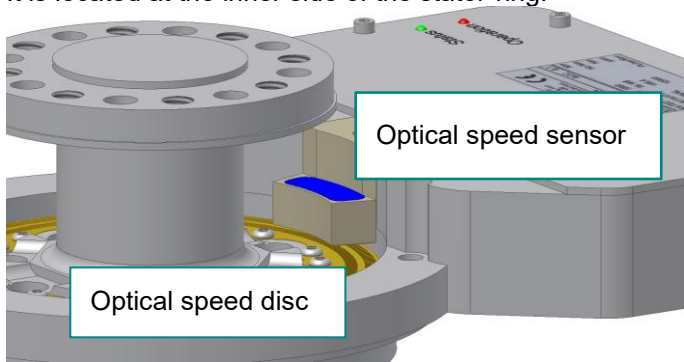

Figure 3-6: Optical speed detection

The speed sensor signals are provided as RS422 signals and as processed values for the analogue outputs and CAN messages. The inductive speed detection cannot be used at the same time with the optical speed detection. The speed detection system can be selected in the configuration.

3.7 Test report and calibration sheets

A test report is supplied with a torque meter, which lists all the parameters required for operation. This includes the two gradients (sensitivities) and the test signal.

Test report example

Torque transducer test report

Serial number: F1iS 6543

Range1			
Rated Torque:	1,000	Nm	
Calibrated Torque:	1,000	Nm	
Sensitivity cw:	19.1520	Hz/Nm	
Sensitivity ccw:	19.1466	Hz/Nm	
Test signal:	522.19	Nm	10001 Hz
Accuracy (Nonlinearity and hysteresis):	0.05% of rated torque		
Temperature effect on zero:	0.05% of rated torque / 10 K		

Nominal Temperatur Range (Rotor/Stator): 0 °C to 80 °C
 Gravitational Constant Alsdorf: 9.81106 m/s²
 Ambient Temperature: 22 °C

Remarks:
 Maximum Speed: 20,000 rpm
 Speed Disc: 60 ppr
 Warming Up Time: 30 minutes

Calibration date: 28.10.2021
 Test date: 28.10.2021
 Signed: *Meyer*

SAMPLE

ATESTEO GmbH & Co. KG · Konrad-Zuse-Str. 3 · 52477 Alsdorf · +49 (0) 24 04-98 70-0 · info@atesteo.com · www.atesteo.com
 Certified according to ISO 9001:2015 and ISO 14001:2015
 Accredited according to ISO 17025



Figure 3-7: Test report of a torque meter

3.7.1 Factory calibration sheet

The clockwise and anticlockwise sensitivities can be found in section "Case II, Linear interpolation equation" (as of January 2023 in 1.2.1 and 1.2.2).

Seite 3 zum Kalibrierschein vom 2022-03-22
Page 3 of the calibration certificate of 2022-03-22

Kalibrieranordnung
Calibrator installation

Einbaueinstellungen Mounting positions	1x120°
Drehmomentvektor Torque vector	vertical vertical
Elastische Kupplung Flexible Coupling	Multi-plate coupling

Umgebungsbedingungen
Environmental conditions

	Anfang Begin	Ende End
Luft-Temperatur Air temperature	21,2 °C	21,1 °C
Rel. Luftfeuchte Rel. Humidity	44 %	44 %

Interpolation
Interpolation

Angaben sind die linearen Interpolationsgleichungen, die der Berechnung der Linearitätsabweichungen zu Grunde liegen. Ermittelt nach der Methode der kleinsten Fehlerquadrate.
The linear interpolation equations, on which the calculation of the linearity deviations are based, are given. Determined according to the least-squares method.

Fall I: Lineare Interpolationsgleichung nur unter Berücksichtigung der Messwerte aus der Aufwärtsreihe ohne Wiederholmessreihe (ohne Berücksichtigung der Umkehrspanne h/ ohne Hysterese).
Case I: Linear interpolation equation only reading of increasing torque without repeatability series are taken into account (without reversal error h/ without hysteresis).

Fall II: Lineare Interpolationsgleichung unter Einbeziehung der Messwerte aus Aufwärts- und Abwärtsreihe (mit Umkehrspanne h/ mit Hysterese).
Case II: Linear interpolation equation taking into account the values from measurement series with increasing and decreasing torque (with reversal error h/ with hysteresis).

1 Interpolationsgleichungen
Interpolation equations

S in kHz M in Nm

1.1 Fall I, Lineare Interpolationsgleichung Case I, Linear interpolation equation

1.1.1 Rechtsdrehmoment clockwise torque $S_{01} = 0,006343 \cdot M_1$ $M_{01} = 157,655 \cdot S_1$	1.1.2 Linksdrehmoment anticlockwise torque $S_{02} = 0,006392 \cdot M_2$ $M_{02} = 157,748 \cdot S_2$
---	--

1.1.3 Rechts- und Linksdrehmoment clockwise and anticlockwise torque
 $S_{03} = 0,0063411 \cdot M_1$
 $M_{03} = 157,701 \cdot S_1$

1.2 Fall II, Lineare Interpolationsgleichung Case II, Linear interpolation equation

1.2.1 Rechtsdrehmoment clockwise torque $S_{04} = 0,006344 \cdot M_1$ $M_{04} = 157,644 \cdot S_1$	1.2.2 Linksdrehmoment anticlockwise torque $S_{05} = 0,006396 \cdot M_2$ $M_{05} = 157,74 \cdot S_2$
---	---

1.2.3 Rechts- und Linksdrehmoment clockwise and anticlockwise torque
 $S_{06} = 0,0063415 \cdot M_1$
 $M_{06} = 157,692 \cdot S_1$

KSNr

WKS

2022-03

ATESTEO GmbH & Co KG Telefon: +49 (0)2404/9870 0 Rev. 3.03
 Konrad-Zuse-Str.3 E-Mail: calibration@atesteo.com
 D-52477 Alsdorf / Germany

Figure 3-8: Extract from the factory calibration certificate

3.7.2 DAKs calibration sheet

The clockwise and anticlockwise sensitivities can be found in section "Case II, Linear interpolation equation" (as of January 2023 in 3.3.1 and 3.3.2)

ATESTEO		KSNr									
Seite 5 zum Kalibrierschein vom 2022-03-22 Page 5 of the calibration certificate of 2022-03-22		D-K 16792 01.00 2022-03									
3 Interpolationsgleichungen Interpolation equations											
		S in digits M in Nm									
3.1 Fall I, Kubische Interpolationsgleichung Case I, Cubic interpolation equation											
3.1.1 Rechtsdrehmoment clockwise torque											
$S_p = 143,023$ M_1^+ $0,0000018$ M_2^+ $-1,8E-09$ M_3^+		$M_0 = 0,0099027$ S_1^+ $-7,4E-12$ S_2^+ $4,2E-18$ S_3^+									
3.1.2 Fallender Betrag des Rechtsdrehmomentes decreasing absolute value of the clockwise torque											
$S_p = 0$ M_1^+ $143,683$ M_2^+ $-0,0000069$ M_3^+ $7E-10$ M_4^+		$M_0 = -0,067607279$ S_1^+ $0,00890752$ S_2^+ $2,32693E-12$ S_3^+ $-1,66E-18$ S_4^+									
3.1.3 Linksdrehmoment anticlockwise torque											
$S_p = 143,818$ M_1^+ $-0,0000049$ M_2^+ $-0,000000003$ M_3^+		$M_0 = 0,0089029$ S_1^+ $8,4E-12$ S_2^+ $7E-18$ S_3^+									
3.1.4 Fallender Betrag des Linksdrehmomentes decreasing absolute value of the anticlockwise torque											
$S_p = 20$ M_1^+ $143,693$ M_2^+ $0,0000084$ M_3^+ $-9E-10$ M_4^+		$M_0 = 0,124629775$ S_1^+ $0,00690693$ S_2^+ $-2,93209E-12$ S_3^+ $2,13E-18$ S_4^+									
3.2 Fall II, Lineare Interpolationsgleichung Case II, Linear interpolation equation											
3.2.1 Rechtsdrehmoment clockwise torque		3.2.2 Linksdrehmoment anticlockwise torque									
$S_p = 143,6926286$ M_1 $S_m = 143,6579250$ M_1		$M_0 = 0,0099059$ S_1									
$M_0 = 0,0099059$ S_1											
3.2.3 Rechts- und Linksdrehmoment clockwise and anticlockwise torque (siehe Fußnote see footnote)											
$S_p = 143,69276$ M_1		$M_0 = 0,0099059$ S_1									
3.3 Fall II, Lineare Interpolationsgleichung Case II, Linear interpolation equation											
3.3.1 Rechtsdrehmoment clockwise torque		3.3.2 Linksdrehmoment anticlockwise torque									
$S_p = 143,699573$ M_1 $S_m = 143,6678747$ M_1		$M_0 = 0,0099054$ S_1									
$M_0 = 0,0099054$ S_1											
3.3.3 Rechts- und Linksdrehmoment clockwise and anticlockwise torque (siehe Fußnote see footnote)											
$S_p = 143,6687239$ M_1		$M_0 = 0,0099054$ S_1									
$M_0 = 0,0099054$ S_1											
4 Momente nach DIN 51351 Classification criteria according to ISO 15425											
Fall I case I		Fall II case II									
M_0 in N.m	M^+ S %	h T ₀ %	M_0 T ₀ %	f_{rel} T ₀ %	f_{rel} T ₀ %	M^+ S %	h T ₀ %	h T ₀ %	f_{rel} T ₀ %	f_{rel} T ₀ %	r
3000	0,021	0,000	-	0,000	0,007	0,001	0,000	-	-	0,002	0,251
2400	0,002	0,000	-	0,000	0,002	0,002	0,000	+	0,007	0,000	0,251
1800	0,004	0,000	-	0,002	-0,003	0,004	0,000	-	0,019	-0,000	0,251
1500	0,007	0,000	-	-0,003	-0,011	0,007	0,000	-	0,028	-0,004	0,251
1200	0,006	0,000	-	0,001	-0,010	0,006	0,000	-	0,030	-0,002	0,251
900	0,002	0,000	-	0,000	-0,015	0,002	0,000	-	0,046	-0,003	0,251
600	0,004	0,000	-	-0,001	-0,020	0,004	0,000	-	0,050	-0,004	0,251
300	0,016	0,000	-	0,005	-0,018	0,016	0,000	-	0,067	0,002	0,251
0	-	-	0,004	-	-	-	0,004	-	-	-	-
-300	-0,019	0,000	-	-0,001	-0,024	-0,019	0,000	-	-0,069	0,012	0,251
-600	-0,015	0,000	-	-0,005	-0,013	-0,015	0,000	-	-0,058	0,007	0,251
-900	-0,018	0,000	-	-0,002	-0,016	-0,018	0,000	-	-0,048	0,001	0,251
-1200	-0,013	0,000	-	-0,002	-0,013	-0,013	0,000	-	-0,047	0,000	0,251
-1500	-0,009	0,000	-	0,000	-0,006	-0,009	0,000	-	-0,039	0,002	0,251
-1800	-0,007	0,000	-	0,001	-0,002	-0,007	0,000	-	-0,027	0,001	0,251
-2400	-0,005	0,000	-	0,000	0,001	-0,005	0,000	-	-0,011	0,000	0,251
-3000	-0,004	0,000	-	0,000	0,006	-0,004	0,000	-	-	-0,001	0,251

Die Bestimmung der linearen Interpolationsgleichung für Rechts- und Linksdrehmoment ist nicht identisch mit einem Kalibrierergebnis für Wechsellastmoment. Sie ermöglicht es, mit nur einem Kalibrierfall das Anzeigergebnis optimal für Rechts- und Linksdrehmoment anzupassen.
The linear interpolation equation for clockwise torque and anticlockwise torque can't be used as a calibration result for alternating torque.
It only can be used to adjust the indicator optimally for clockwise torque and anticlockwise torque with a single calibration factor.

ATESTEO GmbH & Co. KG
Kornatz-Zweigs-33
Tel: +49 (0)2404 9870-0
E-Mail: calibration@atesteko.com

Figure 3-9: Extract from the DAKs calibration certificate

3.8 LED codes

3.8.1 Green LED

In normal mode the green LED is blinking with a frequency of 1 Hz indicating the evaluation unit is powered up. LED is blinking faster during the start-up phase when the supply voltage is automatically adjusted (Auto Setup = On).

3.8.2 Red LED

If the evaluation unit operates faultlessly the red LED is not lighting. If an error occurs (e.g. alarm threshold exceeded) the LED lights blink continuously. If the rotor sends no signal, or the automatic search for the power supply amplitude is active, or the data transfer between stator and rotor is in progress the red LED is blinking.

4 Mechanical Installation

This chapter describes how to install the components. This depends on your test stand or system. The descriptions here are therefore to be understood as examples.

Please be sure to observe the drawings of the torque system.

If you have any questions, please contact our service department.

Observe the safety instructions at 2.6.

4.1 Transport

The torque measuring system is a high-precision measuring system. The components must be handled with appropriate care during transport. ATESTEO recommends using the original packaging. ATESTEO can provide protective cases for common sizes for shipping for calibration.

4.2 Lifting the rotor

The rotor can have a greater weight with a corresponding size that should no longer be lifted by people for reasons of occupational safety. The rotors should therefore be lifted using aids (crane) in compliance with the in-house and legal requirements. Rotors must be set down with the flat flange side facing down. This prevents dangerous rolling away.

Type	Rotor weight
	[kg]
F0xS	1.2
F1xS	4.0
F2xS	13.0

F23xS	22.0
F3xS	39.0
F34xS	31.5
F4xS	77.0
F5xS	96.0
F6xS	155.,0

Table 4-1: Rotor weights

The weights of the RT1eS, RT11eS, TiS, TeS, SiS, SeS and HSSTeS systems are each less than 10kg and are therefore not listed here. Details can be found in the data sheets.

Measuring flange series whose measuring bodies (between the screw-on flanges) are equipped with a protective sleeve must never be lifted by this protective sleeve. This can easily destroy the sensor system.

Instead, use eyebolts on the screw-on flanges, which are screwed into existing threads. Take care not to overload these threads.

If in doubt, ask customer service.

4.3 Stator installation

The installation of the stator depends on the design (iS / eS) of the stator. This chapter describes the installation as an example. The number of screws to be used depends on the size of the measuring system (e.g. F1iS, F2iS, ...) and is specified in the stator drawing accordingly. The thread of the screws must match your machines. Screws of strength/quality 8.8 must be used for stator mounting. The required tightening torque must be determined according to the screw size.

4.3.1 Alignment

The rotor must be correctly aligned with the stator to ensure a stable power supply, correct data transmission and correct speed measurement (with optional speed sensors).

Axial and radial distances must be maintained within the specified tolerance. The basic distances and tolerances are specified in the system drawing. Please note that the values may deviate in the case of optional speed detection.

4.3.2 iS Stator

4.3.2.1 Connecting to a machine

If possible, the stator of the torque sensor should be positioned so that the electronics housing is mounted at 9 o'clock. This prevents leaking liquids from entering the housing. As a further precaution, the electronic components are coated with protective lacquer.

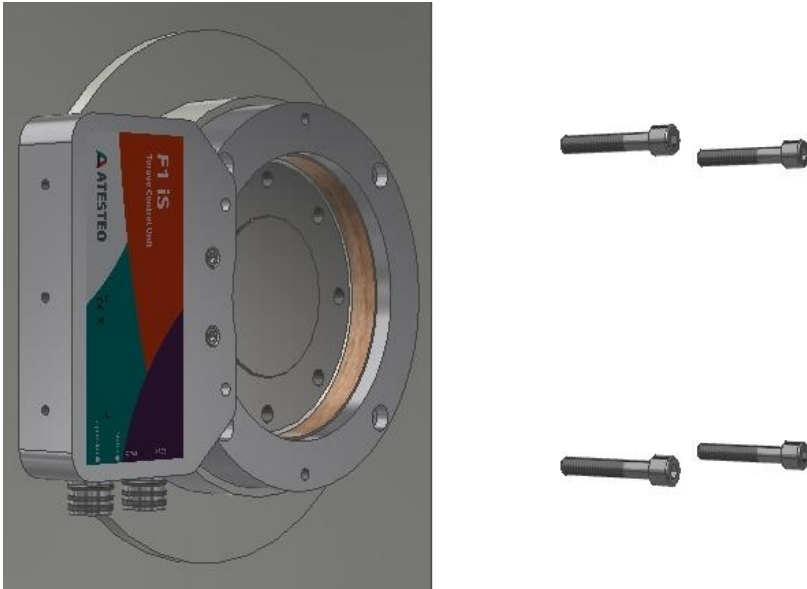

Figure 4-1: Mounting the iS stator

Screws for mounting the different iS stators must match the through holes in the stator. The through hole dimensions can be found on the stator drawings. The screws must be hand-tightened.

4.3.2.2 Foot mounting

As an alternative to flanging onto a machine, an iS stator can be mounted using its base. A base adapter (foot mount adapter) can be purchased from ATESTEO for this purpose. The base adapter is mounted to the lower part of the stator housing using the screws supplied. The foot adapter can then be screwed onto the customised holder.

Mounting via foot adapter is only recommended up to F3iS. Vibration can occur with larger rotors, which can affect the service life and function of the system.

If an optical speed sensor is used, mounting via the foot adapter is not recommended. The alignment (rotor - stator) must be very precise. Unwanted contact between the rotor and stator could occur.

Example of a fully assembled system with an angle bracket manufactured by the customer:

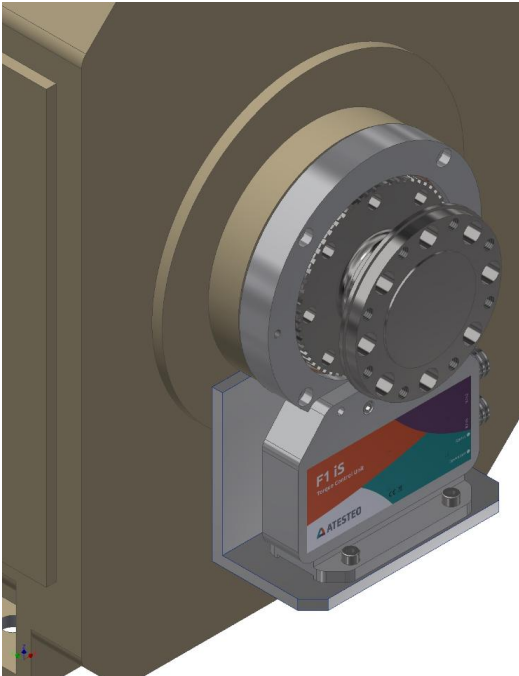

Figure 4-2: Foot mounting via foot adapter (F1iS)

4.3.3 eS Stator

There are no special alignment recommendations for the eS stator. The electronic components on the inside of the stator ring are coated with protective lacquer.

Screws for mounting the different eS stators must match the through holes in the stator. The through holes dimensions can be found on the stator drawings. The screws must be hand-tightened.

4.4 Rotor installation

Before mounting the rotor, optional speed detection systems must be taken into account (see separate chapter). These may need to be partially removed before the rotor is installed so that the rotor can be installed without damaging the speed detection system.

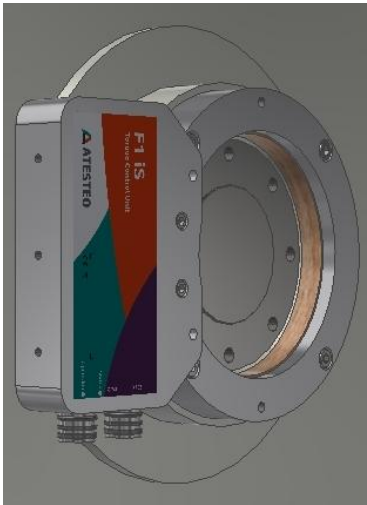

Figure 4-3: Mounting the rotor 1

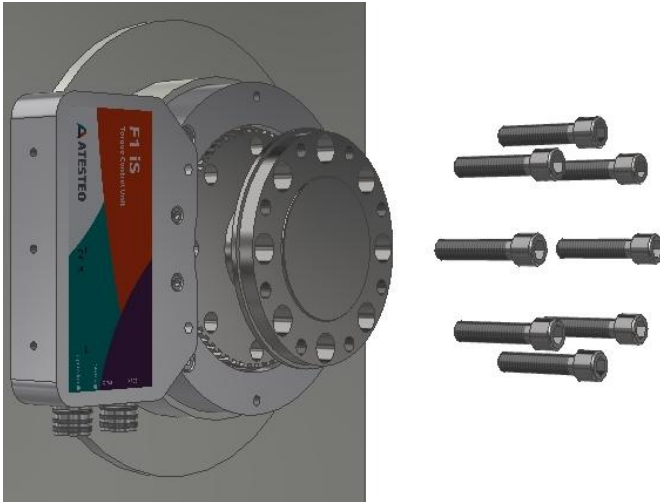

Figure 4-4: Mounting the rotor 2

The screws required for mounting the rotor are specified in the rotor drawings. The minimum length of a screw is 1.2 times its thread diameter plus the thickness of the rotor flange on the side where the screw is used.

4.4.1 Recommended tightening torques

4.4.1.1 FxiS / FxeS

F0iS / F0eS / F0iS-HS / F0eS-HS			
Nominal torque [Nm]	Screws	Screw quality	Tightening torque [Nm]
50	8 * M10	10.9	71
100	8 * M10	10.9	71
200	8 * M10	10.9	71
500	8 * M10	12.9	83
1,000	8 * M10	12.9	83

F0iS-SV / F0eS-SV

Nominal torque [Nm]	Screws	Screw quality	Tightening torque [Nm]
100	4 * M10	8.8	48
200	4 * M10	10.9	71
400	4 * M10	10.9	71
500	4 * M10	10.9	71
1,000	8 * M10	12.9	83

F1iS / F1eS			
Nominal torque [Nm]	Screws	Screw quality	Tightening torque [Nm]
200	8 * M12	10.9	123
500	8 * M12	10.9	123
1,000	8 * M12	10.9	123
1,500	8 * M12	10.9	123
2,000	8 * M12	12.9	144
2,500	8 * M12	12.9	144
3,000	8 * M12	12.9	144

F2iS / F2eS			
Nominal torque [Nm]	Screws	Screw quality	Tightening torque [Nm]
2,500	16 * M16	8.8	206
5,000	16 * M16	8.8	206
7,000	16 * M16	8.8	206
10,000	16 * M16	10.9	302
15,000	16 * M16	12.9	354
20,000	16 * M18	12.9	492

F23iS / F23eS			
Nominal torque [Nm]	Screws	Screw quality	Tightening torque [Nm]

20,000	16 * M20	12.9	692
25,000	16 * M20	12.9	692
30,000	16 * M20	12.9	692

F3iS / F3eS			
Nominal torque [Nm]	Screws	Screw quality	Tightening torque [Nm]
30,000	24 * M20	12.9	692
40,000	24 * M20	12.9	692
50,000	24 * M20	12.9	692

F34iS / F34eS			
Nominal torque [Nm]	Screws	Screw quality	Tightening torque [Nm]
60,000	24 * M22	12.9	950
70,000	24 * M22	12.9	950
80,000	24 * M22	12.9	950

F4iS / F4eS			
Nominal torque [Nm]	Screws	Screw quality	Tightening torque [Nm]
60,000	16 * M30	12.9	2,380
80,000	16 * M30	12.9	2,380
100,000	16 * M30	12.9	2,380
120,000	16 * M30	12.9	2,380

F5eS			
Nominal torque [Nm]	Screws	Screw quality	Tightening torque [Nm]
110,000	16 * M30	12.9	2,380
130,000	16 * M30	12.9	2,380
150,000	16 * M30	12.9	2,380

F6eS			
Nominal torque [Nm]	Screws	Screw quality	Tightening torque [Nm]
200,000	18 * M36	12.9	4,136
250,000	18 * M36	12.9	4,136

Table 4-2: Tightening torques for screws (F series)

	Measuring flange and thread size	Screw-in depth in the measuring flange [mm]		Screw-in depth in the customer flange [mm]
		min.	max.	
F0xS	M10x1.5	11	16	12
F0xS-HS	M10x1.5	11	16	12
F0xS-SV	M10x1.5	11	16	12
F1xS	M12x1.75	14	19	15
F2xS	M16x2.0	17,5	22,5	20
F23xS	M20x2.5	25	30	24
F3xS	M20x2.5	25	30	24
F34xS	M22x3.0	25	30	27
F4xS	M30x3.5	40	45	36
F5xS	M30x3.5	40	45	36
F6xS	M36x4.0	40	45	44

Table 4-3: Thread sizes and screw-in depths (F series)

4.4.1.2 TxS / SxS

TiS Z50 / TeS Z50			
Nominal torque [Nm]	Screws	Screw quality	Tightening torque [Nm]
50	8 * M10	8.8	48
100	8 * M10	8.8	48
200	8 * M10	8.8	48

500	8 * M10	8.8	48
-----	---------	-----	----

SiS Z50 / SeS Z50			
Nominal torque [Nm]	Screws	Screw quality	Tightening torque [Nm]
500	8 * M10	10.9	71
1,000	8 * M10	12.9	83

Table 4-4: Tightening torques for screws (T series)

	Measuring flange and thread size	Screw-in depth in the measuring flange [mm]		Screw-in depth in the customer flange [mm]
		min.	max.	
TxS Z50	M10x1.5	12	17	12
SxS Z50	M10x1.5	12	17	12

Table 4-5: Thread sizes and screw-in depths (T-series)

4.4.1.3 RT1eS (steel) & RT11eS (titanium)

RT1eS			
Nominal torque [Nm]	Screws	quality	Tightening torque [Nm]
5	4 * M8	8.8	24.6
10	4 * M8	8.8	24.6
20	4 * M8	8.8	24.6
25	4 * M8	8.8	24.6
50	4 * M8	8.8	24.6
100	4 * M8	10.9	36.1

RT1eS-B ETP			
Nominal torque [Nm]	Screws	quality	Tightening torque [Nm]
5	8 * M6	8.8	10.1

10	8 * M6	8.8	10.1
15	8 * M6	8.8	10.1
20	8 * M6	8.8	10.1

RT1eS-B RW			
Nominal torque [Nm]	Screws	Screw quality	Tightening torque [Nm]
5	8 * M6	8.8	10.1
10	8 * M6	8.8	10.1
15	8 * M6	8.8	10.1
20	8 * M6	8.8	10.1

Table 4-6: Tightening torques for screws (RT1 series)

RT11eS			
Nominal torque [Nm]	Screws	quality	Tightening torque [Nm]
5	4 * M8	8.8	24.6
10	4 * M8	8.8	24.6
20	4 * M8	8.8	24.6
25	4 * M8	8.8	24.6
50	4 * M8	8.8	24.6

RT11eS-B ETP			
Nominal torque [Nm]	Screws	quality	Tightening torque [Nm]
5	8 * M6	8.8	10.1
10	8 * M6	8.8	10.1
15	8 * M6	10.9	14.9
20	8 * M6	10.9	14.9

RT11eS-B RW			
Nominal torque	Screws	Screw	Tightening torque

[Nm]		quality	[Nm]
5	8 * M6	8.8	10.1
10	8 * M6	8.8	10.1
15	8 * M6	10.9	14.9
20	8 * M6	10.9	14.9

Table 4-7: Tightening torques for screws (RT11 series)

Measuring flange and thread size	Screw-in depth in the measuring flange [mm]	Screw-in depth in the customer flange [mm]	
		min.	max.
RT1eS / RT11eS	M8x1.25	8	13
RT1eS-B ETP / RT11eS-B ETP	M6x1.0	-	-
RT1eS-B RW / RT11eS-B RW	M6x1.0	-	-

Table 4-8: Thread sizes and screw-in depths (RT1 series and RT11 series)

4.4.1.4 HSTTeS

HSTT1eS			
Nominal torque [Nm]	Screws	Screw quality	Tightening torque [Nm]
50	6 * M6	8.8	10.1
100	6 * M6	8.8	10.1

HSTT2eS			
Nominal torque [Nm]	Screws	Screw quality	Tightening torque [Nm]
200	8 * M6	10.9	14.9

Table 4-9: Tightening torques for screws (HSTT series)

Measuring flange and thread size		Screw-in depth in the measuring flange [mm]		Screw-in depth in the customer flange [mm]
		min.	max.	
HSTT1eS	M6x1.0	6	11	8
HSTT2eS	M6x1.0	66	11	8

Table 4-10: Thread sizes and screw-in depths (HSTT series)

4.5 Installation of speed detection systems

4.5.1 Installation of inductive speed detection

For the F1xS and F2xS systems, the distance was set correctly at the factory and cannot be modified. For the F23xS, F3xS, F34xS, F4xS and F5xS systems, the distances are preset and can be changed if necessary.

4.5.2 Installation of magnetic speed detection

To set the correct distances, loosen 2 screws as shown in the illustration below. The nominal distance and tolerance range depend on the system and are specified on the dimensional system drawing.

Once the distance has been set, the two screws must be hand-tightened.

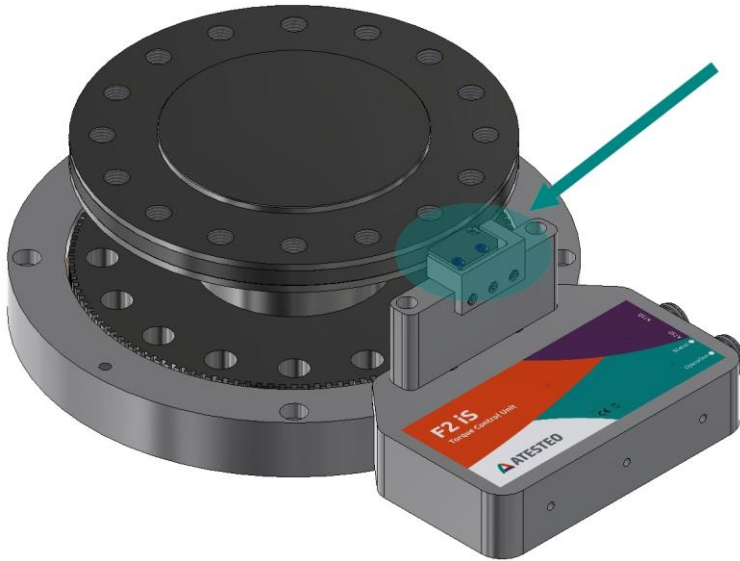

Figure 4-5: Adjustment of correct distance

4.5.3 Installation of optical speed detection

Before mounting the rotor on the already mounted stator, the metal block of the optical speed sensor must be removed from the stator. This is done by loosening the central screw. After mounting the rotor and its fixed slotted disc, the block can be screwed back into its old position (iS variant see Figure 4-6 and Figure 4-7, eS variant see Figure 4-8 and Figure 4-9).

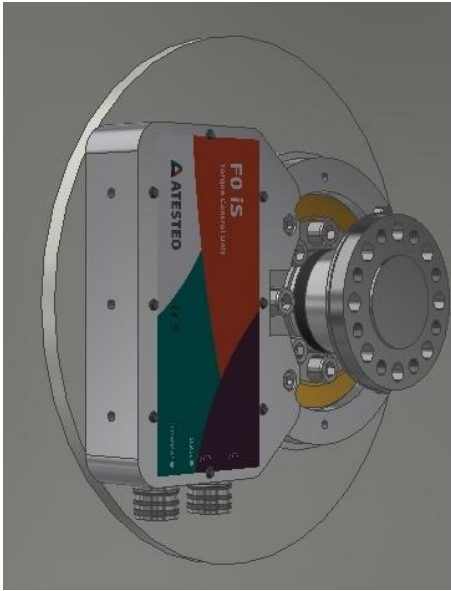

Figure 4-6: Mounting the optical speed measurement system step 1 (iS variant)

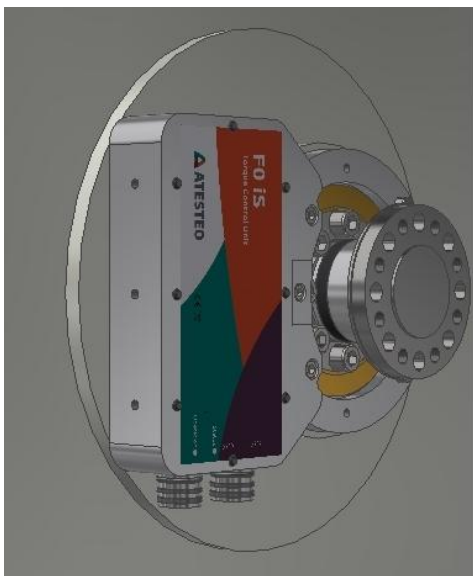

Figure 4-7: Mounting the optical speed measurement system step 2 (iS variant)

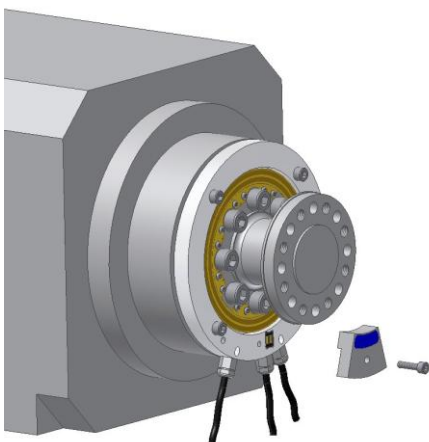

Figure 4-8: Mounting the optical speed measurement system step 1 (eS variant)

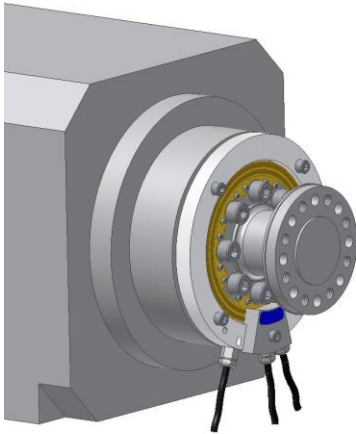

Figure 4-9: Mounting the optical speed measurement system step 2 (eS variant)

If the evaluation unit (TCU2 or electronics in the iS stator) is replaced, the optical speed measurement must be recalibrated. This is necessary because a change in the distance between the speed disc and the aperture on the receiver side causes a change in the amplitude of the signal. In addition, the electrical properties can vary from module to module. To perform the calibration, potentiometers located on the evaluation unit's circuit board (within the TCU2 or the iS-stator) must be adjusted. An oscilloscope is also required to verify the measurements. Instructions and technical support are available upon request from the Service Department.

The position of the optical speed disc on the speed module is set at the factory and does not need to be adjusted.

The optimum position of the speed measurement system is determined by positioning the rotor to the stator.

The permitted radial and axial distances can be found in the dimensional system drawing.



Before commissioning, check whether the measuring flange can be turned by hand without rotating parts touching stationary parts.

4.6 Installation of the evaluation unit (TCU2)

The external evaluation unit (TCU2, for eS variants) can be screwed to a support via four holes in the housing. The hole dimensions can be found in the drawings. Top-hat rail mounting is not intended.

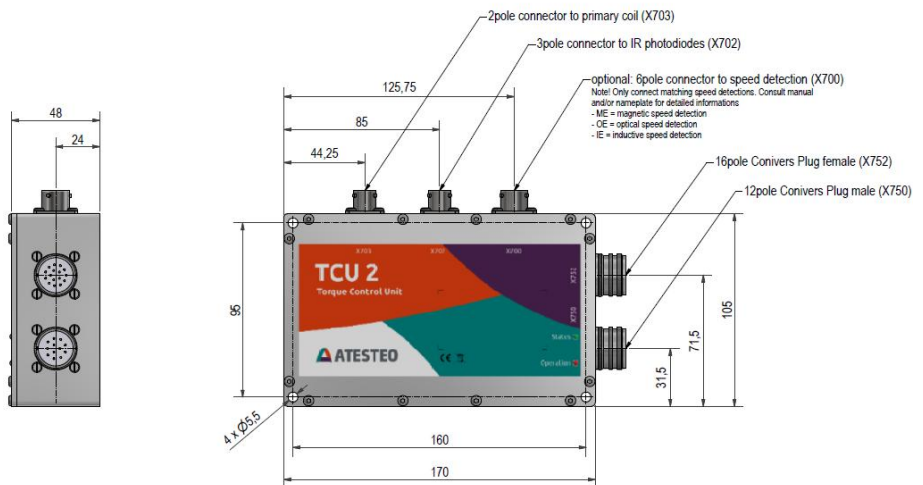

Figure 4-10: Dimensions of the TCU 2 evaluation unit

5 Electrical installation

The parts delivered are dependent upon customer specific orders. If you have ordered a complete measurement system, all electrical and software parameters are pre-installed.

5.1 Connection to mains

The purchased ATESTEO measuring systems must be powered with DC voltage of 23-25V. The power input depends on the sensor system. The energy consumption lies between 4 and 17 watts. The power supply must be protected with a 2AT fuse against overcurrent.

5.2 Connecting torque meter/evaluation unit with the data acquisition system

To keep the EMV – Norm EN61000-6-4 / VDE 0839 parts 6-4, the following procedure to handle the connecting cable is recommended.

Please use shielded servo cable with 4x 2x 0.14mm² (twisted pair) + 4x 0,5mm² wire for the connection to X750 and shielded servo cable with 8x 2x 0.25mm² wire (twisted pair) for the connection to X 751/752.

The shielding of the cable must be connected to the connectors on both ends.

The TCU2 housing must have the same ground potential as the eS stator ring. Machine parts are often varnished. An additional electrical connection between both parts is recommended.

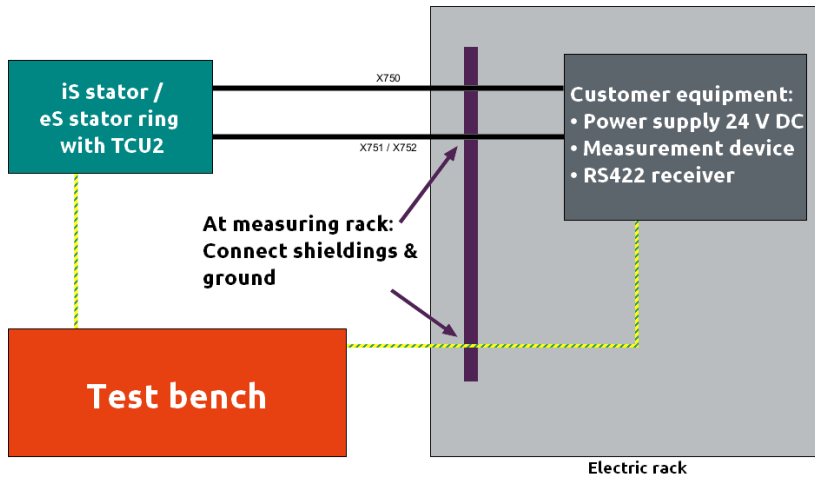

Figure 5-1: Grounding scheme

5.3 Analogue outputs

5.3.1 Output A (Voltage)

Output A can only be used as a voltage output. The measurement signals torque and speed can be applied to the output. If the current output (MD I) is switched on, no signal is fed to output A.

5.3.2 Output B (Voltage)

Output B can only be used as a voltage output. The measurement signals torque or speed can be applied to the output.

5.3.3 Output C (State)

Output C can only be used as a voltage output. If analogue output C is set to status, it outputs the status via the stator. At an output voltage of 4.9V,

the torque measuring flange operates without errors, while at a voltage of 0.1V there is an error and the torque meter must be checked.

If the output voltage is permanently lower than 0.1V, there is a cable break.

During the self-test, the status channel (analogue output C) remains at 0 V. If the self-test is completed without an error, the voltage rises to 4.9 V. In the event of an error, the voltage changes to 0.1 V.

Output voltage channel C	Description
<0.1 V	Cable break or self-test in progress. In the event of a cable break, check the electrical connections.
0.1 V	Error or not in operating mode! Look at the error code displayed to determine the error in more detail.
4.9 V	No error, operating mode active.

Table 5-1: Description of the voltage levels of output C (status)

Alternatively, the temperature at the electronics of the evaluation unit (eS: TCU2, iS: stator housing) can be transmitted via output C. 1V corresponds to 100 °C.

5.3.4 MDI (Current output)

The current output can be used as an option. It can be used to transmit a torque signal. If the current output is activated, no value is transmitted to output A (voltage).

5.4 Digital inputs/outputs

5.4.1 Input “control signals”

The “Control” input signal can be used to trigger self-test, zero adjustment or test signal.

5.4.1.1 Self-test

Set Control = 24 V for 3 seconds. With the falling edge of the input signal, the self-test is triggered (see 3.5.1).

5.4.1.2 Zero adjustment

Set Control = 24 V for 5 seconds. With the falling edge of the input signal the zero-point is calibrated (see 3.5.2).

5.4.1.3 Test signal

Set Control = 24 V for 7 seconds or more. After 7 seconds, the test signal (see 3.5.3) will be engaged if the signal has a voltage level of 24V. By setting Control=0V the test signal will be disabled.

5.4.2 Digital Alerts

5.4.2.1 Alert Md/N

If the alarm thresholds have been exceeded due to overload or over-speed the open collector outputs "Alarm Md" and "Alarm N" are set. The digital outputs are open-collector types, so that the measured output signal is inverted. The maximum collector-emitter voltage is maximum rated with 36V (50mA).

For circuit details and sample circuit please refer to chapter 5.6.

5.4.2.2 Alert IR

If the data transmission between the rotor and the stator can no longer be guaranteed faultless, the output "Alarm IR" is set. The degree of failure is observed by monitoring the intensity of infrared light being transmitted. The threshold is factory calibrated and cannot be altered.

For circuit details and sample circuit please refer to chapter 5.6.

5.4.2.3 Reset alerts

If alarm thresholds are exceeded the corresponding digital output is set. With the help of the input "Reset Alarm" it is possible to reset the alarms being displayed. The status bits are also cleared when using this feature. Apply a voltage >4V to trigger the reset function. The maximum input voltage is rated with 30V.

For circuit details and sample circuit please refer to chapter 5.6.

5.5 Pin assignments iS and eS type

The evaluation unit uses two device connectors at the output. The respective plug designation can be found on the housing cover of the evaluation unit. Device plugs X750 and X751/752 connect the evaluation unit to the test stand peripherals. Only use the following cable plugs to connect to the device plugs:

Device plug	Cable plug (manufacturer - manufacturer part number)
X750 (12-pin)	Hummel - 7106500000 + Hummel - 7001912104
X751/752 (16-pin)	Hummel - 7106500000 + Hummel - 7001916103

*1) not included in the scope of delivery

Table 5-2: Connector: Manufacturer part numbers

5.5.1 Connector X750

X750 12-pin socket (customer side) Hummel 7.106.500.000 Hummel 7.001.912.104 Mains connection Measuring signals RS422 Md - Torque N - speed	1 N inductive - 2 N inductive + 3 N2+ (magn. / opt., optional) 4 N2- (magn. / opt., optional) 5 N1+ (magn. / opt., optional) 6 N1- (magn. / opt., optional) 7 Mdf1- 8 Mdf1+ 9 Control (see 5.4.1) 10 VCC 24V 11 GND 12 GND
--	---

Table 5-3: Connector X750

RS422 signals have a level of approx. 3.7 V. Use as a TTL signal without a corresponding converter is not recommended.

Cable type: LI-2YC11Y 250V si/gr 4x0.5+4x2x0.14

1	RS422	N inductive-	twisted pair 0.14mm ²	White
2	RS422	N inductive+		Brown
3	RS422	N2+	twisted pair 0.14mm ²	Grey
4	RS422	N2-		Pink
5	RS422	N1+	twisted pair 0.14mm ²	Blue
6	RS422	N1-		Red
7	RS422	Mdf1-	twisted pair 0.14mm ²	Yellow
8	RS422	Mdf1+		Green
9		Control	0.5mm ²	White
10	U in	24V 2A	0.5mm ²	Green

11		GND	0.5mm ²	Yellow
12		GND	0.5mm ²	Brown

Table 5-4: Cable X750

5.5.2 Connector X751/X752

X 751/ X752 16 Pol. Plug (customer side) Bumblebee 7.106.500.000 Bumblebee 7.001.916.103 Analogue/digital Measuring signals Md - Torque N - Speed	1 TXD RS232 ($\pm 5V$ differential) 2 RXD RS232 ($\pm 5V$ differential) 3 GND ($\pm 5V$ differential) 4 GND 5 CAN High 6 CAN Low 7 MD I out (current) 8 Analogue output B (voltage) 9 Analogue output C (voltage) 10 Analogue output A (voltage) 11 Digital output alarm Md 12 GND 13 Digital output alarm N 14 Digital output alarm IR 15 Digital input alarm reset 16 Digital input DT2 (in)
---	--

Table 5-5: Connector X751 / X752

Cable type: LIYCY 250V 8x2x0.25

16-pin Conivers, pin assignment				
1	RS232	TXD	twisted pair	White
2	RS232	RXD	0.25mm ²	Brown
3		GND	twisted pair	Green
4		GND	0.25mm ²	Yellow
5		CANH	twisted pair	Grey
6		CANL	0.25mm ²	Pink
7		MD I out	twisted pair	Blue

8	Analogue out B	0.25mm ²	Red
9	Analogue out C	twisted pair 0.25mm ²	Black
10	Analogue out A		Purple
11	Alarm Md	twisted pair 0.25mm ²	Grey / Pink
12	GND		Red / Blue
13	Alarm N	twisted pair 0.25mm ²	White / Green
14	Alarm IR		Brown / Green
15	Reset alarm	twisted pair 0.25mm ²	White / Yellow
16	DT2 in D		Brown / Yellow

Table 5-6: Cable X751/X752

It is recommended to establish the RS232 connection to a computer only for configuration purposes and to disconnect it during operation.

5.6 Electrical circuits

5.6.1 RS422 outputs

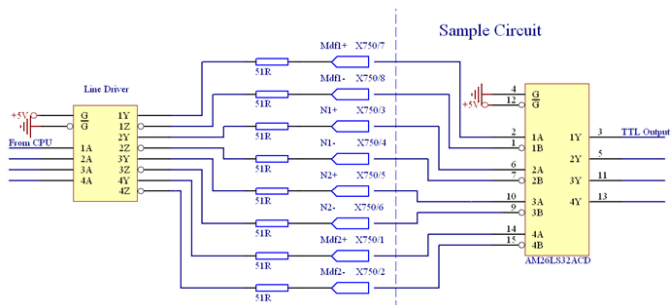

5.6.2 Alert outputs

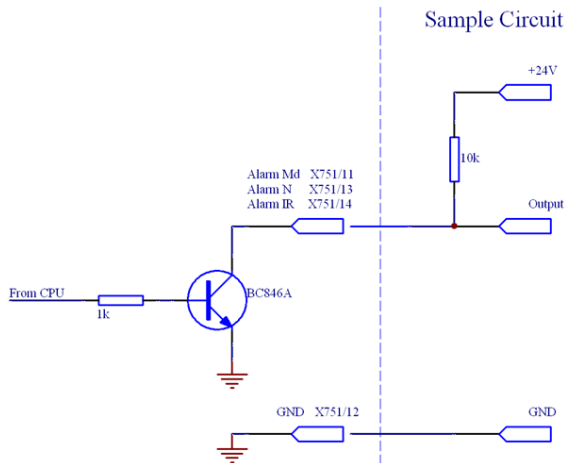

5.6.3 Alert reset input

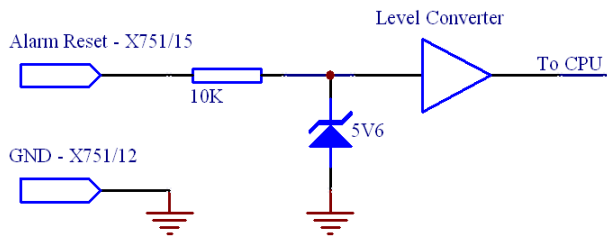

5.6.4 Control input

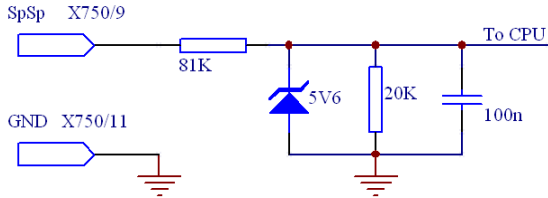

5.6.5 Analogue output A/B (Voltage)

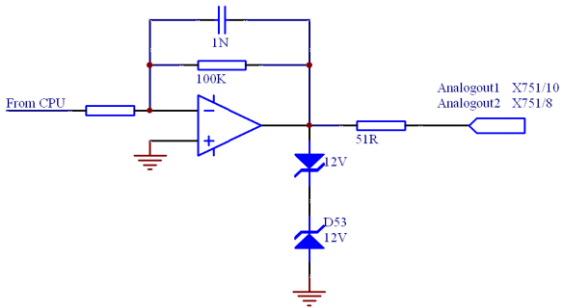

5.6.6 Analogue output C (Voltage)

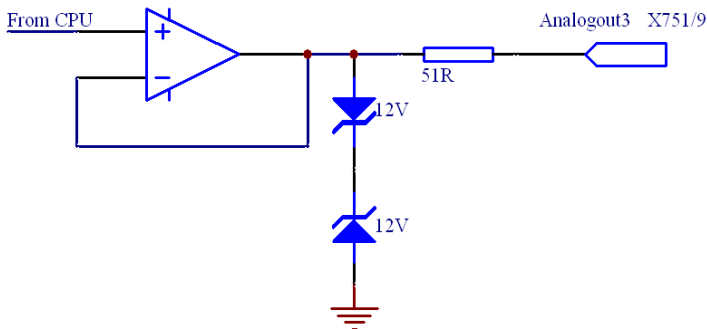

5.6.7 Current output (MDI)

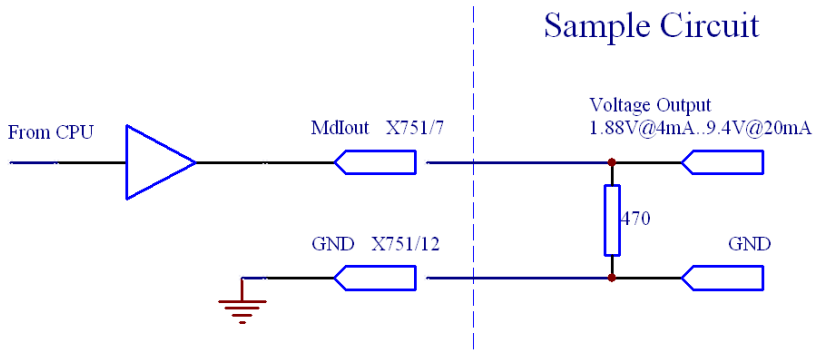

5.6.8 RS232

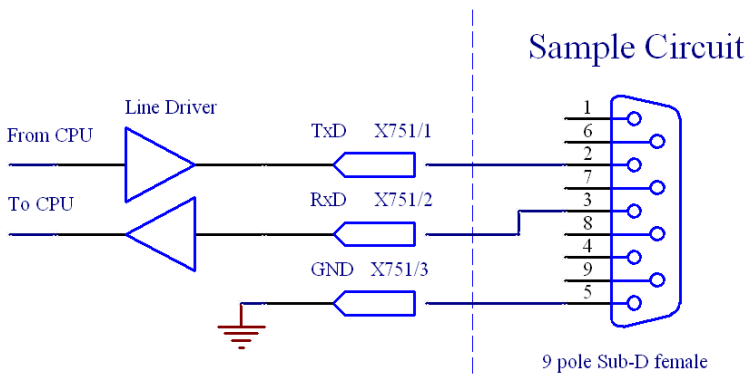

5.6.9 CAN

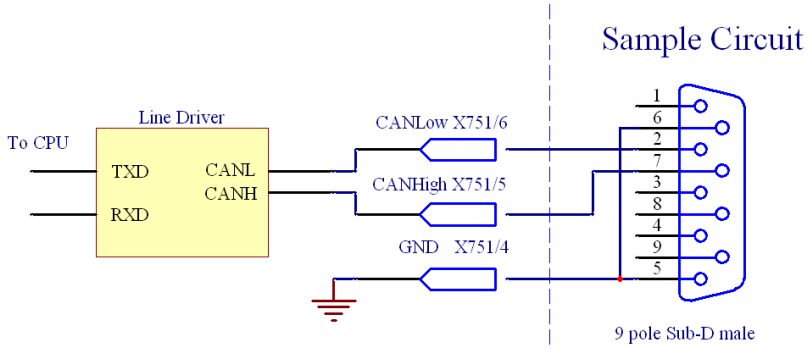

6 First Installation

6.1 Initial installation

If you have purchased a complete torque measurement system consisting of a rotor and a corresponding stator, you may skip the following articles. Otherwise the following adjustments of the default settings are absolutely necessary to properly run the system!

6.2 Replacing the torque meter

For more flexibility, the iS and eS torque meters are interchangeable with the same stator. All you need to do is enter the operating parameters contained in the test report for torque meters. This report is supplied with the new system (see 3.7). The parameters can be set using the TCU-Config software or a terminal (see 7).

7 Configuration

7.1 Software TCUConfig

Connect the torque meter to the serial interface. Install the program TCUConfig on your PC and start the program.

TCUConfig can be downloaded free of charge from the ATESTEO website.

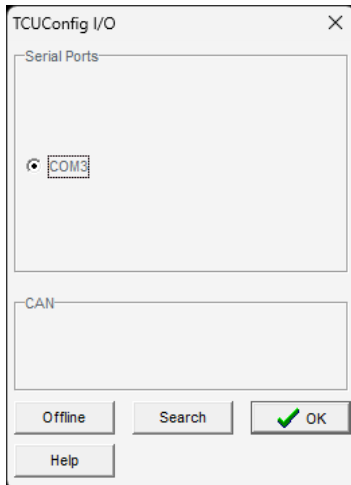

Figure 7-1: TCU configuration

The TCUConfig program scans all ports after you press “Search”. Select the port which is connected to the torque meter. It is also possible to work offline with the setup program. In this case you can store a parameter list for later use.

If you have some Bluetooth interfaces or other measurement equipment at the serial port, it can be that the “Search Routine” doesn’t work and the program hangs up. In this case select only the used serial port.

Flu/F2i Config

File Torquemeter COM-Port Terminal Service Measure DT2 Info Help

ATESTEO

Torque transducer test report

Serial number Rotor: 4793

Range 1

Rated Torque 1 / Nm: 80

Sensitivity clockwise / Hz/Nm: 936.0000

Sensitivity anticlockwise / Hz/Nm: 935.5500

Range 2

Rated Torque 2 / Nm:

Sensitivity clockwise / Hz/Nm:

Sensitivity anticlockwise / Hz/Nm:

Speed sensor

Speed B - Imp/Rev magnetopt: 400

Speed A - Imp/Rev inductive: 60

Max Speed / rpm: 25000

Stator information

Serial number Stator: 12524

Hardware Version: 2010200

Software Version: 3.00

Active interface: Serial

Alarm

Torque

Range 1: n/a

Torque minimum / Nm: -2000

Torque maximum / Nm: 2000

Speed

Speed minimum / rpm: -10000

Speed maximum / rpm: 10000

Filter

HIR

Output 1: OFF

Output 2: OFF

Average

Speed A:

Speed B:

Analog output

Output 1

10V to 10V

Output 2

Speed B

10V to 10V

Output 3

Status

0V to 5V

Current Out

On Off

Current Range

0 - 20 mA 4 - 20 mA

Measurement

Torque

Torque 1: -0.050Nm

Speed

Speed B: 0.0rpm

Show Status | Reset Status

CAN interface

Transmission: On Off

State: Status

Bus speed: 1 M 600 K 250 K 125 K

Identifier: 11 Bit 29 Bit

Data format: Long Float

Identifier length: Intel Motorola

Identifier	Byte 7 ... Byte 4	Byte3 ... Byte 0	values/s
f80	Torque 1 Filter A	Speed B	1000
f00	Torque 1 Filter B	Speed B	OFF
f02	Torque 2 Filter A	Speed B	OFF
f03	Torque 2 Filter B	Speed B	OFF
f04	Torque 1 Filter A	Torque 2 Filter B	OFF
f05	Torque 1 Filter B	Torque 2 Filter B	OFF
f06	Torque 1 Filter A	Speed A	OFF
f07	Torque 1 Filter B	Speed A	OFF
f08	0x0000	Alarm	OFF
f09	Torque Min/Max	Speed Min/Max	OFF
f10	Temperature	Status	OFF

Figure 7-2: Settings after selecting the correct connection

7.1.1 Setup inductive power supply

The stator automatically adjusts the inductive voltage supply after switching it on. The frequency of the torque signal is then approximately 60,000 Hz. This process can be triggered manually under the menu item "Service Setup inductive Power supply" (see 3.5.4).

7.1.2 Torque zero adjustment

With a right click on the torque value, a context menu is shown. Click on menu item "Set Torque = 0" to start the zero adjustment. (alternatively main menu "Torquemeter" -> "set torque output = 0"). See also 3.5.2.

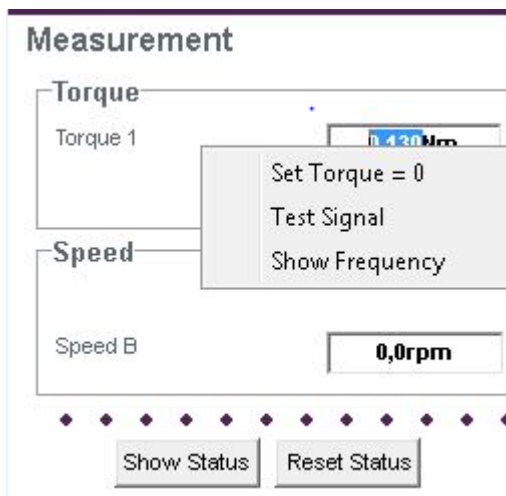

Figure 7-3: Torque zero adjustment

7.1.3 Test signal

In the same context menu as shown in 7.1.2, the test signal can be activated by clicking on menu item "Test Signal" (see also 3.5.3).

7.1.4 Setup of the calibration parameters

Torque transducer test report	
Serial number Rotor	<input type="text" value="4783"/>
Range 1	
Rated Torque 1 / Nm	<input type="text" value="20"/>
Sensitivity clockwise / Hz/Nm	<input type="text" value="936.0000"/>
Sensitivity anticlockwise / Hz/Nm	<input type="text" value="935.5500"/>
Range 2	
Rated Torque 2 / Nm	<input type="text"/>
Sensitivity clockwise / Hz/Nm	<input type="text"/>
Sensitivity anticlockwise / Hz/Nm	<input type="text"/>
Speed sensor	
Speed B - Imp/Rev magn/opt	<input type="text" value="480"/>
Speed A - Imp/Rev inductive	<input type="text" value="60"/>
Max Speed / rpm	<input type="text" value="25000"/>

Figure 7-4: Setup of calibration parameters

Fill in the form showed above with the parameters from the torque transducer test report. These parameters are very important to get the right physical values at the analogue output, the display and the CAN Interface.

7.1.5 Setup analogue output

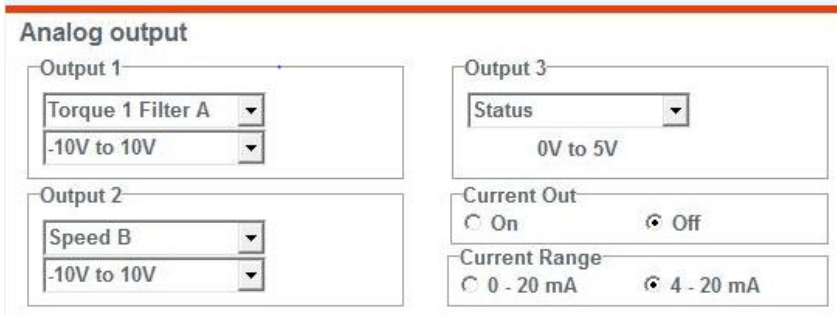

Analog output

Output 1
 Torque 1 Filter A
 -10V to 10V

Output 2
 Speed B
 -10V to 10V

Output 3
 Status
 0V to 5V

Current Out
 On Off

Current Range
 0 - 20 mA 4 - 20 mA

Figure 7-5: Setup analogue output

The torque meters of the F series contain up to three (A / B / C) analogue outputs that can output voltages. It is possible to select different signals for the analogue output. Depending on which accessories are connected, the menu shows different options for the corresponding analogue output.

For **Output1 (A) / Output2 (B)** it is possible to choose between:

- Torque 1 Filter A
- Torque 1 Filter B
- Speed (magnetic/optical) with filter
- Speed (inductive) with filter
- Torque 2 Filter A
- Torque 2 Filter B

For **Output3 (C)** it is possible to choose between:

- Internal temperature
- Status
- Acceleration X
- Acceleration Y

It is not possible to output one and the same channel to two outputs.
The output range in voltage mode can be selected between

- -10V to 10V
- -5V to 5V
- 0 to 5V
- 0 to 10V

For circuit details and circuit examples, please refer to the chapter 5.

7.1.6 Setup current output

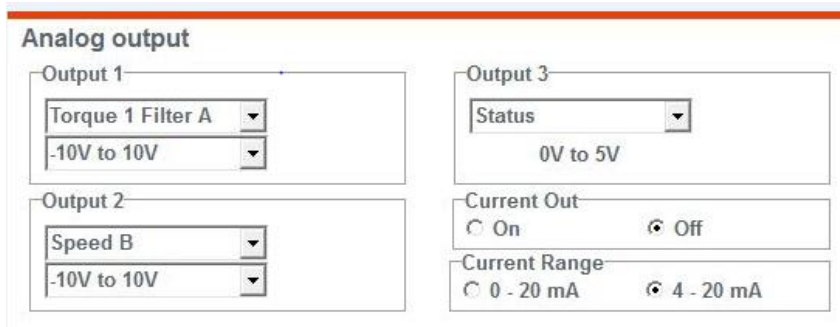

Analog output

Output 1
Torque 1 Filter A
-10V to 10V

Output 2
Speed B
-10V to 10V

Output 3
Status
0V to 5V

Current Out
 On Off

Current Range
 0 - 20 mA 4 - 20 mA

Figure 7-6: Setup current output

The current output can be switched on or off in this menu. Moreover, it is possible to select between 0-20 mA and 4-20 mA. If the current output is switched on, it can be tapped via analogue output "MD I out".

7.1.7 Setup filter

Filter

IIR

Output 1	Off ▼
Output 2	Off ▼

Average

Speed A	▼
Speed B	▼

Figure 7-7: Setup filter

The filters set here affect the analogue outputs and the CAN output, but not the frequency output. Two filters are available simultaneously for the torque signal.

This means that one filter can be used for the automation program and another for the measured value recording. Filters A and B of the torque signal are IIR filters. The speed signals are filtered with a "moving average" filter. See Table 7-4.

7.1.8 Setup alarm



The screenshot shows a software interface for setting alarm limits. It is titled "Alarm" and contains two main sections: "Torque" and "Speed".

Torque Section:

- Range 1: n/a
- Torque minimum / Nm: -2000
- Torque maximum / Nm: 2000

Speed Section:

- Speed minimum / rpm: -10000
- Speed maximum / rpm: 10000

Figure 7-8: Setup alarm

The alarm limits for the speed signal and the torque signal can be set here. Circuit details and circuit examples can be found in chapter 5.

7.1.9 Setup CAN interface

CAN interface

Transmission: On Off State:

Bus speed: 1 M 500 K 250 K 125 K

Identifier: 11 Bit 29 Bit Data format: Long Float Identifier length: Intel Motorola

Send / Receive: Receive Identifier:

Identifier	Byte 7 ... Byte 4	Byte3 ... Byte 0	values/s
100	Torque 1 Filter A	Speed B	1000
101	Torque 1 Filter B	Speed B	OFF
102	Torque 2 Filter A	Speed B	OFF
103	Torque 2 Filter B	Speed B	OFF
104	Torque 1 Filter A	Torque 2 Filter A	OFF
105	Torque 1 Filter B	Torque 2 Filter B	OFF
106	Torque 1 Filter A	Speed A	OFF
107	Torque 1 Filter B	Speed A	OFF
108	0x0000	Alarm	OFF
109	Torque Min/Max	Speed Min/Max	OFF
110	Temperature	Status	OFF

Figure 7-9: Setup CAN interface

In the "CAN interface" area, select the settings that match your CAN bus. The transmission of data can be switched on or off via "Transmission".

Send / Receive
Receive Identifier

Identifier	Byte 7 ... Byte 4	Byte3 ... Byte 0	values/s
180	Torque 1 Filter A	Speed B	1000 ▾
100	Torque 1 Filter B	Speed B	OFF ▾
102	Torque 2 Filter A	Speed B	OFF ▾
103	Torque 2 Filter B	Speed B	OFF ▾
104	Torque 1 Filter A	Torque 2 Filter A	OFF ▾
105	Torque 1 Filter B	Torque 2 Filter B	OFF ▾
106	Torque 1 Filter A	Speed A	OFF ▾
107	Torque 1 Filter B	Speed A	OFF ▾
108	0x0000	Alarm	OFF ▾
109	Torque Min/Max	Speed Min/Max	OFF ▾
110	Temperature	Status	OFF ▾

Figure 7-10: Signals at CAN bus

You can choose which signals shall be sent on the CAN bus and which data rates should be applied. The identifier is the message ID in decimal format. The value of the output data depends on the selected format and the measured value. When the data format 'long' is selected, the measured values are multiplied by a certain factor to retain decimal places. Thus, the received data must be divided by that factor by the acquisition system to get back the measured data.

Measured Value: float	Measured Value: long (x factor)	Unit
Speed inductive	Speed inductive x 10	rpm
Speed magnetic\optical	Speed magnetic\optical x 10	rpm
Torque	Torque x 1000	Nm
Torque Min/Max (int)	Torque Min/Max (int) x 10	Nm
Speed Min/Max (int)	Speed Min/Max (int) x 10	rpm
Temperature Stator	Temperature Stator x 1000	°C
Status (long)	Status	
Alarm (long)	Alarm	

Table 7-1: Possible data which can be sent by CAN interface

This table shows the possible data which can be sent by the CAN interface. Every CAN message consists of an identifier and two different measured values. For each pair of measured values you can select a separate data transmit interval.

With the above settings the message 180 will be sent with 1,000 values / s:

Long	0				1			
Byte	0	1	2	3	4	5	6	7
	Speed B				Torque 1 Filter A			

Table 7-2: Example of data sent by CAN interface

7.2 Terminal program

If the program “TCUConfig” is not available, you can conduct all the settings using a terminal program.

7.2.1 Main Menu

To activate the serial interface, press the key '#’.

```
*****
*                               All-In-One   V2.49.2010202   S/N 0
*                               *****
Torque 1                        -0.0          (a) Set Zero
Mag/Opt Speed                   -   0.0          (b) Test Signal
Ind. Speed                       0.0          (c) Reset Status

Frequency - Torque 1             59993
Frequency - Mag/Opt Speed        0
Frequency - Ind. Speed           0

Stator Temperature               44.1

Test Counter                     0

CAN error                        2
Status                           0x00000802

Operating hour                   13:21:51:20

-n- Refresh -F- Filter -A- Alarm -O- Output -T- Torquemeter -S- Setup
```

Figure 7-11: Terminal program: Main menu

On the left side the values for torque and speed are shown as well as the internal stator temperature and status indicators.

Key	Description
a	Zero calibration. Set torque = 0; Attention: Be sure that no torque is invoked when setting to zero torque! See 8.5.
b	Activate the test signal. The rotor supplies a frequency shift of 10 kHz from center frequency.
c	Reset the status word. (see 5.4.2.3)
F	Submenu: Filter settings for torque and speed
A	Submenu: Alarm thresholds for torque and speed
O	Submenu: Configure analogue and digital outputs (analogue/CAN)
T	Submenu: Torque meter settings (sensitivity/rated torque)
S	Submenu: Setup settings and calibration routines (analogue/CAN)
CAN error	0– no error 1- <128 errors/s 2- >128 errors/s 3-Bus off

Table 7-3: Key description of the terminal program

7.2.2 Filter settings

Different digital filters can be activated in the stator.

- Two independent IIR filters are dedicated to the torque channel with 6 different cut-off frequencies.
- One moving average filter is provided for the built-in speed sensors. (The optical/magnetic speed sensors, as shown in the picture below, are optionally available).

```
*****
*                               Filter Settings                               *
*****

TORQUE FILTER
(1) Filter A                off
(2) Filter B                100Hz

SPEED FILTER
(3) Mag/Opt Speed          off
(4) Ind. Speed             120

-n- Refresh                -e- EXIT_
```

Figure 7-12: Terminal program: Filter settings

Key	Description
1	Cut-off frequency (-3dB) of filter A for torque measurement Filter settings: -0- off -1- 250Hz -2- 150Hz -3- 100Hz -4- 50Hz -5- 10Hz -6- 1Hz
2	Cut-off frequency (-3dB) of filter B for torque measurement. (Filter settings see above)
3	Moving average filter depth for the magnetic or optical speed sensor (optional). -0: off -2 ... 199: Averaging over 0 to 199 values.
4	Moving-average filter depth for the inductive speed sensor (standard). -0: off -2 ... 199: Averaging over 0 to 199 values.

Table 7-4: Key description of filter settings

7.2.3 Alarm settings

Use the menu to configure the switching of the digital alarm outputs (alarm points).

```

*****
*                               Alarm Settings                               *
*****
TORQUE
(1) Maximum Torque 1             2000
(2) Minimum Torque 1            -2000

SPEED
(5) Maximum Speed               10000
(6) Minimum Speed               -10000

-n- Refresh                      -e- EXIT_

```

Figure 7-13: Terminal program: Alarm settings

Key	Description
'1'	Alarm threshold max. torque
'2'	Alarm threshold min. torque
'5'	Alarm threshold max. speed (inductive and magnetic)
'6'	Alarm threshold min. speed (inductive and magnetic)

Table 7-5: Key description of alarm setting

7.2.4 Output settings

The measured values for speed and torque can be output both as an analogue signal and as a CAN value. Each output channel can be set individually.

To output the values as a CAN message, it is sufficient to set the identifier and the sampling rate. A minimum time interval of 1 ms can be selected. The total number of transmitted data per second is limited by the CAN bus speed, therefore the continuously transmitted data rate is calculated and displayed as "current measuring rate". The preset maximum data rate cannot be exceeded or changed. To change the CAN bus settings, please refer to 7.1.7.

If the mounted measuring system does not appear in the selection, it must be activated with the "TCUConfig" software, menu "Service" "Setup Speed Sensor" or in terminal "output settings" "x".

For circuit details and circuit examples, please refer to the chapter 5.

```
*****
*                                     Output Settings                             *
*****

ANALOG OUTPUTS
(a) Analog Output A:      Md1 FA
(b) Analog Output B:      N mag/optMd1 FA
(c) Analog Output C:      Status

Current Messagerate:      252[Msg/sec]

CAN OUTPUT
DATA                      IDENTIFIER [dec]  TX INTERVAL [ms]
Alarm threshold           (1)             108      (f)         0
Minimum-Maximum          (2)             109      (g)         0
Status/Temperature        (3)             110      (h)         500
Md / N mag/opt Filt A    (4)             100      (i)         4
Md / N mag/opt Filt B    (5)             101      (j)         0
Md / N ind - Filter A    (6)             106      (k)         0
Md / N ind - Filter B    (7)             107      (l)         0

(x) Speed Sensor Type:    mag. and ind/opIntel

-n- Refresh  -e- EXIT
```

Figure 7-14: Terminal program: Setting the outputs

Key	Description
'a', 'b'	Signal selection for the analogue output A / B -0- Md1 filter A -1- Md1 filter B -2- N magn. filter (optional) -3- N ind. filter

'1'..'7'	CAN identifier
'f'..'l'	CAN sampling rate
'x'	Installed speed sensor
Current measuring rate	Maximum adjustable "measuring rate" 1Mbps 6500msg/s 500kbps 3700msg/s 250kbps 1850msg/s 125kbps 1000msg/s 100kbps 800msg/s 10kbps 76msg/s

Table 7-6: Key description for the analogue output settings

7.2.5 Torque meter settings

To adapt a torque meter to an evaluation unit the calibration parameters obtained from the 'Torque Transducer Test Report' must be correctly filled out in the 'Torquemeter Settings' menu. The frequency registered as 'Zero Output' is acquired when performing a zero adjustment [(a) Set Zero] .

```

*****
*                               Torquemeter Settings                               *
*****

  MD Type                0          (7) Zero Output [Hz]          59994
(b) Serial Number       1321

(1) Sensitivity + [Hz/Nm] 31.5792  (9) Calibration Jump [V]      16.3
(2) Sensitivity - [Hz/Nm] 31.5792  (0) Calibration Jump [Hz]     2988
(3) Rated Torque [Nm]    650.0

                               (p) PS. on/off                1
                               (s) PS. voltage                 14.4
                               (y) PS. AUTO voltage

                               Frequency - Torque 1          59993

(x) Imp/Rev ind.         60
(z) Imp/Rev mag/opt      600
(m) Max. Speed [rpm]    25000  (a) Set Zero

-n- Refresh      -r- Read Param.   -S- Selftest                               -e- EXIT

```

Figure 7-15: Terminal program: Torque meter settings

Key	Description
'b'	The Serial number from the enclosed torque meter is shown.
'1'	Sensitivity + characteristic value: torque meter torque clockwise (pos).
'2'	Sensitivity - characteristic value: torque meter torque anticlockwise (neg).
'3'	Rated Torque of the system.
'x'	Number of pulses per revolution of the inductive speed sensor (fixed by mechanical design of the torque meter).
'z'	Impulses per revolution (speed measuring system)
'm'	Maximum speed Full scale value of analogue output.
'7'	Zero Output (Zero frequency) This value is automatically acquired when performing a zero adjustment.
'9'	Calibration Jump [V] Necessary inductive power supply amplitude to engage the test signal. This parameter is calculated automatically and must not be altered by the user!
'0'	Calibration Jump [Hz] Test signal frequency shift in Hz. This parameter is calculated automatically and must not be altered by the user!
'p'	PS. on/off Turn inductive power supply on/off.
's'	PS. Voltage Voltage amplitude of the inductive power supply.
'y'	PS. Auto voltage Automatically setup the inductive power supply. The following parameters are redefined (s) PS. Voltage

Key	Description
	(7) Zero Output (9) Calibration Jump [V] (0) Calibration Jump [Hz]
'a'	Zero calibration. Set torque = 0; Attention: Be sure that no torque is invoked when setting to zero torque! See 8.5.
'r'	Read parameters stored into the rotor electronics.
'S'	Perform self-test of the measuring system

Table 7-7: Key description torque meter settings

7.2.5.1 Setting the calibration parameters

The sensitivities can be found on the test report or the calibration certificate (see 3.7).

You can use the terminal program to set the parameters for the connected torque measuring system. Take the parameters (1, 2, 3, b) from the test report of the torque measuring system and enter the properties as shown.

Parameter 1: Sensitivity +

Parameter 2: Sensitivity -

Parameter 3: Rated torque

Parameter b: Serial number

The dot (.) is the decimal separator.

After these steps, the frequency Md1 must be approximately 60,000 Hz.

7.2.5.2 Supply search process

For each new installation (torque meter / stator), it is recommended to adjust the inductive power supply. The amplitude of the inductive power supply can be set automatically by pressing 'y'. (see also 3.5.4).

7.2.5.3 Zero adjustment

The zero-point adjustment can be carried out using the 'a' button. Chapter 3.5.2 must be observed.

7.2.6 Read parameters

The calibration parameters can be obtained from the 'Torque Transducer Test Report' as well as read out of the torque meter electronics itself. After

the transfer procedure is performed the user is prompted to setup the evaluation unit with the read values.

```
*****
*                               PARAMETER FROM TORQUEMETER                               *
*****

read parameter ...      10100001010

Typ                    0      Temp1 electr.                    36.4
Serial number          1321   Temp2 middle                   33.6
Sensitivity1-          31.5792 Temp3 output                   32.4
Sensitivity1+          31.5792 Temp4 input                    34.1

Rated torque1          650.0      Temp max.                    77.2

map error:  0:192

Setup with new values? (y/n)_
```

Figure 7-16: Terminal program: Parameter from torque meter

After pressing the key 'Y', the parameters received from the torque meter will be stored into the evaluation unit (Stator).

7.2.7 Self-test

The self-test (see 3.5.1) is performed. If an error occurs, this is indicated as an error code.

```
*****
*                               Selftest                               *
*****

read parameter ...           10100001010

Serial no. old                1321
Serial no. new                1321
Sensitivity1 old              31.5792      31.5792
Sensitivity1 new              31.5792

Vcc= Vcc + 0,3V              14.7      o.k.
                               59993
Vcc= Vcc - 0,3V              14.1      o.k.
                               59993
Vcc= Cal                       16.3      o.k.
                               62982

Error Code                    0_
```

Figure 7-17: Terminal program: Self-test

7.2.8 Analogue setup

In order to adapt the analogue outputs to the existing measured value acquisition, it is possible to set the offset voltage and the output voltage range.

Note: The analogue outputs are calibrated during the production process of the evaluation unit. It is not recommended to have the analogue outputs calibrated by untrained people.

For circuit details and circuit examples, please refer to the 5.

```

Tera Term - COM1 VT
File Edit Setup Control Window Help
*****
*                               Analog Setup                               *
*****
(A) Calibrate Analog Output A
(B) Calibrate Analog Output B
(C) Calibrate Analog Output C

(1) Offset Analog A [V]          0.000
(2) Offset Analog B [V]          0.000
(3) Offset Analog C [V]          0.000

(5) Analog Output Range A      -10V..+10V
(6) Analog Output Range B      -10V..+10V

(9) Activate Current Output      0
(0) Current Output Range        4..20mA
(1) Calibrate Current Output

-n- Refresh                               -e- EXIT

```

Figure 7-18: Terminal program: Analogue setup

Key	Description
'A'..'C'	Calibration of the analogue outputs. The calibration parameters were determined by ATESTEO and have been saved into the unit. No calibration is needed!
'1'..'3'	It is possible to set an offset voltage for each analogue output.
'5', '6'	Setting the output voltage range.
'9'	Active analogue current output. Attention: If the current output is active, the output voltage in channel A is not output correctly!
'0'	Select the output range of the current output.
'1'	Calibration of the current output. The calibration parameters were determined by ATESTEO and have been saved into the unit. No calibration is needed!
'4'	The Input Control is used to switch between the two channels of a dual range torque meter.

Table 7-8: Key description of analogue setup

7.2.9 CAN setup

The CAN bus setting allows the user to customise the measuring system CAN interface to their own requirements. The baud rate, the identifier length and the number format can be set here.

For circuit details and circuit examples, please refer to the chapter 5.

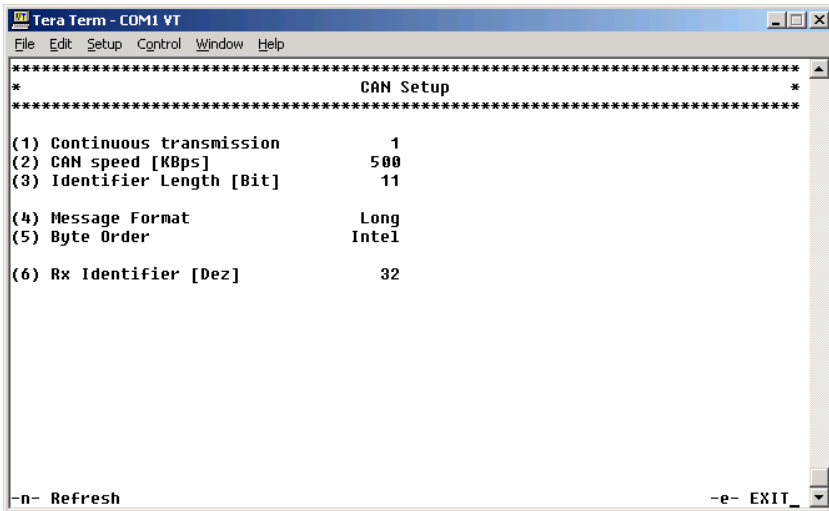

```

Tera Term - COM1 VT
File Edit Setup Control Window Help
*****
*                               CAN Setup                               *
*****
(1) Continuous transmission           1
(2) CAN speed [KBps]                500
(3) Identifier Length [Bit]          11
(4) Message Format                    Long
(5) Byte Order                       Intel
(6) Rx Identifier [Dez]              32

-n- Refresh                               -e- EXIT_
  
```

Figure 7-19: Terminal program: CAN setup

Key	Description
'1'	If activated, the defined messages will be transmitted (activate data transmission).
'2'	CAN bus speed -1000- 1Mbps -500- 500kbps -250- 250kbps -125- 125kbps -100- 100kbps -10- 10kbps

'3'	Length of the message identifiers -11- 11 bit -29- 29 bit
'4'	Numeric format transmitted in a message -long- 32bit signed integer -float- 32bit IEEE754 floating point value
'5'	Byte order inside a CAN message -Intel- The data transfer begins with the least significant byte. -Motorola- The data transfer begins with the most significant byte.
'6'	The CAN identifier dedicated to the command messages the stator receives to be externally controlled.

Table 7-9: Key description CAN setup

7.3 CAN bus

With the following messages it is possible to control the evaluation unit:

Note: The values must be sent as "long" even if "float" is selected as numeric data format. The right identifier length (11 or 29 Bit) must be set.

Identifier: 11Bit / 29Bit

Long	0				1				
Integer	0		1		2		3		
Byte	0	1	2	3	4	5	6	7	
	0				2000				CAN message transmission start
	0				2001				CAN message transmission stop
	0				1201				Zero adjustment. See 3.5.2.
	0				1202				Activate test signal
	0				1203				Deactivate test signal

	0	1211	Reset status
	0	1212	Request status
	0	1213	Request serial number of torque meter
	0	1214	Perform self-test

Table 7-10: Identifier: 11 Bit / 29Bit

Reply from torque meter (rx-identifier + 1)

Long	0				1				
Integer	0		1		2		3		
Byte	0	1	2	3	4	5	6	7	
	Last command				X				

Table 7-11: Reply from torque meter (rx-identifier + 1)

Read serial number:

Reply from torque meter (rx-identifier + 1)

Long	0				1				
Integer	0		1		2		3		
Byte	0	1	2	3	4	5	6	7	
	Last command				Serial number				

Table 7-12: Reply from torque meter (rx-identifier + 1)

Read status:

Reply from torque meter (rx-identifier + 1)

Long	0				1				
Integer	0		1		2		3		
Byte	0	1	2	3	4	5	6	7	
	Last command				Status				

Table 7-13: Reply from torque meter (rx-identifier + 1)

Status 32 Bit (format long)

ST Bit 7	ST Bit 6	ST Bit 5	ST Bit 4	ST Bit 3	ST Bit 2	ST Bit 1	ST Bit 0	Self-test active	Selection 1	Selection 0	Error 1	Error 0	Overflow	Zero-point reset	Test signal
1	1	1	1	1	1	0	0	0	0	0	0	0	0	0	0
5	4	3	2	1	0	9	8	7	6	5	4	3	2	1	0
							Simulation				Alarm IR	Alarm N min	Alarm N max	Alarm Md min	Alarm Md max
3	3	2	2	2	2	2	2	2	2	2	2	1	1	1	1
1	0	9	8	7	6	5	4	3	2	1	0	9	8	7	6

Table 7-14: Status 32 Bit (format long)

Alarm 32 Bit (format long)

												Alarm IR	Alarm N min	Alarm N max	Alarm Md min	Alarm Md max
1	1	1	1	1	1	0	0	0	0	0	0	04	03	02	01	00
5	4	3	2	1	0	9	8	7	6	5						

Table 7-15: Alarm 32 Bit (format long)

(Upper 16 Bits not used. Read out as zeroes)

Min/Max (format int)

Speed Minimum			Speed Maximum		
31		16	15		0
Torque Minimum			Torque Maximum		
63		48	47		32

Table 7-16: Min/Max (format int)

After the zero-point adjustment procedure the status bit 'zero-point reset' is set. It can only be cleared by resetting the status word. With the help of the error code, it is possible to check whether the command is accomplished successfully or not.

Error 0/1:

Error 1	Error 0	
0	1	Zero-point reset not possible
1	0	No calibration jump

Table 7-17: Error 0/1

Selection 0/1:

Selection 1	Selection 0	
0	0	Md1 / N1
0	1	Md2 / N1
1	0	Md1 / Md2

Table 7-18: Selection 0/1

ST bits:

ST Bit7	ST Bit6	ST Bit5	ST Bit4	ST Bit3	ST Bit2	ST Bit1	ST Bit0	
							1	SP + 0,5V Md1 not stable
						1		SP + 0,5V Md1 not stable
					1			SP CAL No calibration jump
				1				Self-test not active
			1					Found new values for inductive power supply
		1						Same serial number different sensitivity
	1							Can't read sensitivity
1								New torque meter installed New sensitivity saved

Table 7-19: ST bits

8 General information

8.1 Overvoltage protection

To prevent damage to the rotating transmitter module, the electronics on the transmitter side switch off in the event of overvoltage. The analogue output of the torque measurement signal then displays undefined values. If this occurs, the amplitude of the supply voltage must be reduced. Sometimes it may be necessary to switch the device off and on again briefly to deactivate the overvoltage protection.

8.2 Torque meter without test signal

In some cases, it is possible that the torque flange supports no test signal. Please refer to your calibration sheet to see the right values.

8.3 Calibration

ATESTEO recommends regular calibration of the torque meters. Depending on the standards and requirements, calibration may be necessary every 1-2 years.

ATESTEO offers the following calibrations in its own DAkkS-accredited calibration laboratory:

- DIN51309
- VDI/VDE 2646
- Factory calibration

Contact: calibration@atesteo.com

8.4 Service hotline

At any troubles, call our hotline workdays from 8:00h to 17:00h **+49 (0)2404-9870-580**
or you can reach us by email service-pm@atesteo.com

8.5 Recommendations for the zero-point adjustment

For every measuring element that consists of an elastic spring body and whose measured variable is derived from the deformation of this spring body, the display often outputs a measured value that deviates from zero without a mechanical load being present.

Regarding strain gauge-based torque measurement systems, zero-point deviations in the load-free state are essentially caused by the following factors:

8.5.1 Thermal influences

Despite elaborate temperature compensation, a temperature-related zero-point drift can always be detected depending on the measuring flange temperature. As the measuring flange is constantly exposed to other temperature influences, this drift occurs both during operation and during downtimes. The temperature stability specified in the technical data (e.g. 0.05%/10K) refers to a permissible temperature drift of $\pm 0.05\%$ of the measuring range end value per 10 Kelvin temperature change. When determining this characteristic value, a homogeneous temperature distribution of the measuring flange is assumed. The temperature change refers to the flange temperature at the time of the last zero-point adjustment.

8.5.2 Hysteresis-related influences

If a torque meter is primarily operated in one torque direction during test bench operation, a torque value may be displayed at the end of the test cycle whose value is not due to temperature-related influences. Rather, this effect is due to hysteresis-related influences and is caused both by the hysteresis properties of the actual measuring body and by the sensor (strain gauge) or its application.

The amount of residual torque output depends on the level and duration of the last torque that occurred during the test operation and can correspond to the maximum value specified in the accuracy class.

Before changing the measuring range, it is therefore recommended to perform an unloading run (see Figure 8-1). If technically possible, a zero-point adjustment should be carried out (see 3.5.2).

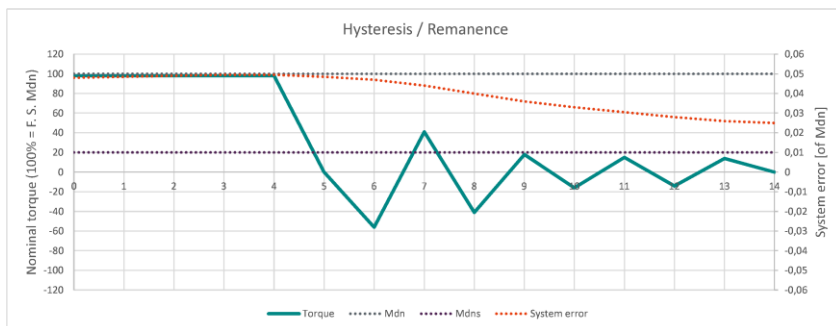

Figure 8-1: Exemplary unloading run when changing the measuring range

The turquoise line shows the torque. 100% corresponds to the nominal torque of the large measuring range (grey, dotted line). After prolonged loading with maximum torque, the real error (red line) may reach the nominal error of the accuracy class. Alternating loads with lower torque lead to a relief of the measuring body. The measurement error is reduced, and the accuracy is optimised for subsequent measurements in the small measurement range (purple, dotted line).

8.5.3 Ageing

If transducers applied with strain gauges are subjected to dynamic loads over long periods of time, a zero-signal drift occurs over time, the amount of which depends on the number of load cycles and the strain amplitude. The higher the typical sensitivity of the actual transducer, the earlier this zero signal drift occurs. Although this effect applies in principle to all strain gauge transducers, the influence on the ATESTEO torque transducers is considered to be extremely low, as the typical strains under full load are considerably lower than the typical strain values of comparable transducers.

8.5.4 Influence of lateral forces

As each measuring flange is part of a drive train, a more or less large proportional mass of the coupled shaft train always acts on the measuring body in the form of an additional transverse force. This transverse force or the resulting bending moment is superimposed on the actual useful signal and leads to a torque signal that deviates from zero depending on the rotational position, even when the system is at a standstill. With proper test stand design, lateral forces are minimal, and their resulting influence on the useful signal need not be taken into further account. The data sheet specifies the lateral force that induces an error of approximately 0.3% in the useful signal.

8.5.5 General

For all the factors mentioned above that influence the zero-point of the torque measuring flange, the sensitivity value derived from the calibration is not affected. The prerequisite for this is that no damage to the measuring body and the strain gauge application point has occurred during the operating time.

Since each of the above mentioned influencing variables affect the zero-point and the zero-point stability simultaneously, but with different values, no generally valid recommendation for resetting this output value can be given.

Based on our experience and the information we have received from our customers, we can only make a few recommendations and comments on resetting to zero.

- Zeroing or taring the system may only be carried out if it is ensured that no torques are acting on the measuring body.
- If a high zero-point deviation (>10 Hz) is detected during installation of the torque meter, please check the mechanical properties of the adapter flange. A smaller zero-point deviation can be readjusted.
- The test engineer must decide whether the accuracy requirements of the measurement task make it necessary to reset the zero-point. In general, the temperature-dependent zero-point deviation can be further improved during a test run if the system is warmed up before starting the actual measurement.
- If zero-point deviations generally occur that are more than 2% of the measuring range end value, the measuring flange must be removed and checked. This check, which includes a calibration as well as further tests, should be carried out by the manufacturer so that the causes of this behavior can be found and rectified.

9 Appendix

9.1 Special DT2 functions

9.1.1 Channel selection by using an external signal

Please read the chapter on general CAN setup (7.3) before setting up the DT2 function.

Menu 'Settings' 'Analogue'

(4) Special DT Function = 1

```

*****
*                               Analog Setup                               *
*****
(A) Calibrate Analog Output A
(B) Calibrate Analog Output B
(C) Calibrate Analog Output C

(1) Offset Analog A [V]          0.000
(2) Offset Analog B [V]          0.000
(3) Offset Analog C [V]          0.000

(4) Special DT Function           1

(5) Analog Output Range A        0V..+10V
(6) Analog Output Range B        0V..+10V

(9) Activate Current Output       0
(0) Current Output Range         4..20mA
      nt Output                   -

-n- Refresh                       -e- EXIT

```

Figure 9-1: Analogue settings menu

With this the following Inputs / Outputs are active.

X751 / X752 PIN 16

Channel 1 -> torque 1 -> low range

Channel 2 -> torque 2 -> high range

Connector	Name	PIN	In/Out	Level	Function
X751/752	DT2	16	IN	0V or open	Switch to channel 2 (high range)
X751/752	DT2	16	IN	5V-24V	Switch to channel 1 (low range)
X751/752	Analogue out C	9	Out	0.1V	Channel 2 active (high range)
X751/752	Analogue out C	9	Out	2.5V	System busy
X751/752	Analogue out C	9	Out	4.9V	Channel 1 active (low range)
X751/752	Analogue out A	10	Out	Selected Range	if Pin9= 0.1V -> channel 2 if Pin9= 4.9V -> channel 1 if Pin9= 2.5V -> not defined

Table 9-1: Connector specification X751 / X752

9.1.2 Channel selection by using a terminal program

Connect the serial interface and start a terminal program. Press the '#' key.

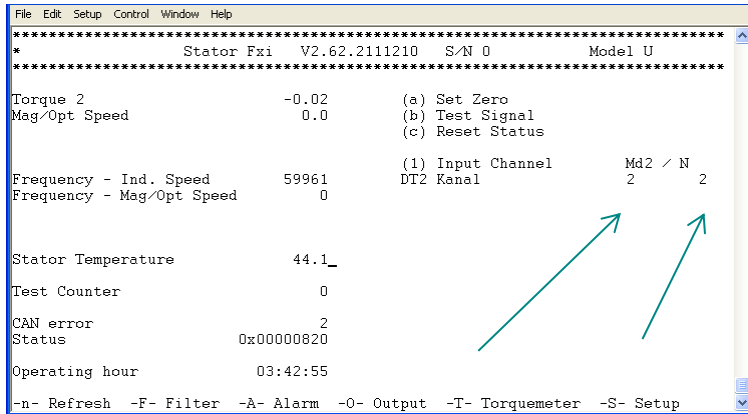

Figure 9-2: Tera Term

- (1) Input channel = 1 Change to channel 1 (low torque range)
- (1) Input channel = 2 Change to channel 2 (high torque range)

DT2 channel indicates active channel.

DT2 channel	Function
1	Channel 1 (low torque range active)
2	Channel 2 (high torque range active)
3	ERROR Channel undefined

Table 9-2: DT2 channel displays active channel

```

*****
*           Stator Fxi   U3.000.2011210   S/N 12524
*****

Torque 1           0.00      (a) Set Zero
Mag/Opt Speed     0.0       (b) Test Signal
                               (c) Reset Stat

Frequency - Torque 1  60099  (1) Input Channel
Frequency - Mag/Opt Speed  0   DT2 Channel

Stator Temperature   32.4

Test Counter         0

CAN error            2
Status               0x00000002

Operating hour       220:19:12:25

-n- Refresh -F- Filter -A- Alarm -O- Output -T- Torquemeter -S- Setup

```

Select channel

Channel select

-1- Md1 / N1 0
-2- Md2 / N1 1
Out_Kana12 0

Figure 9-3: Submenu

If you switch between the two ranges using the terminal, '(4) Special DT Function' is set to 0 in the analogue setup, but is not saved. After switching the device on and off, the system switches to the channel selected by X751 / 752 pin 16. If you only want to switch via terminal or CAN, set '(4) Special DT Function. = 0' using the terminal.

9.1.3 Channel selection by using the CAN interface

Please read the chapter 7.1.9 & 7.2.9 for CAN setup.

Long	0				1				
Integer	0		1		2		3		
Byte	0	1	2	3	4	5	6	7	
	0				1205				Md1 (Torque1) channel1 / N
	0				1206				Md2 (Torque2) channel2 / N

Table 9-3: Channel selection by using a CAN interface

N = speed

Md1 = torque1 = channel1 = low range

Md2 = torque2 = channel2 = high range

If you switch between the two ranges with the help of the CAN interface

'(4) Special DT Function' will be set to 0, but not saved.

After switching off / on the unit the system switches to the channel which is selected by X751/752 Pin 16.

If you want to switch only by terminal or by CAN then set

'(4) Special DT Function=0' with the help of the terminal.

Example of ‘Output Settings’:

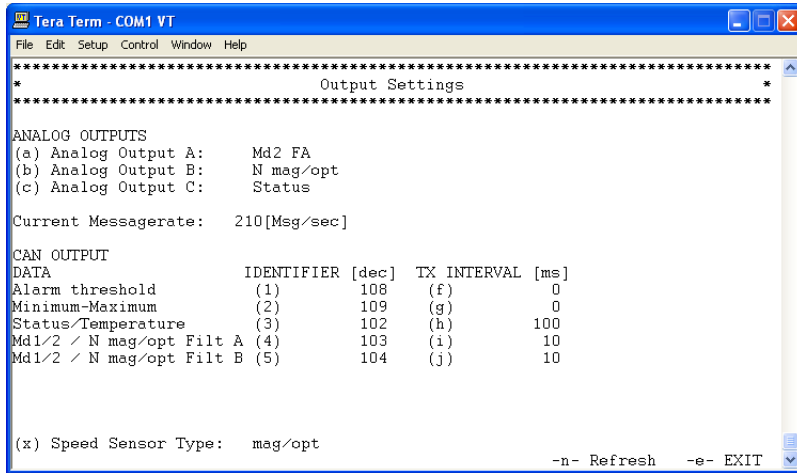

```

Tera Term - COM1 VT
File Edit Setup Control Window Help
*****
*                               Output Settings                               *
*****
ANALOG OUTPUTS
(a) Analog Output A:      Md2 FA
(b) Analog Output B:      N mag/opt
(c) Analog Output C:      Status

Current Messagerate:     210[Msg/sec]

CAN OUTPUT
DATA                     IDENTIFIER [dec] TX INTERVAL [ms]
Alarm threshold          (1)          108      (f)          0
Minimum-Maximum         (2)          109      (g)          0
Status/Temperature      (3)          102      (h)         100
Md1/2 / N mag/opt Filt A (4)         103      (i)          10
Md1/2 / N mag/opt Filt B (5)         104      (j)          10

(x) Speed Sensor Type:   mag/opt

-n- Refresh  -e- EXIT
  
```

Figure 9-4: Example Output settings

Example of 'Setup' 'CAN':

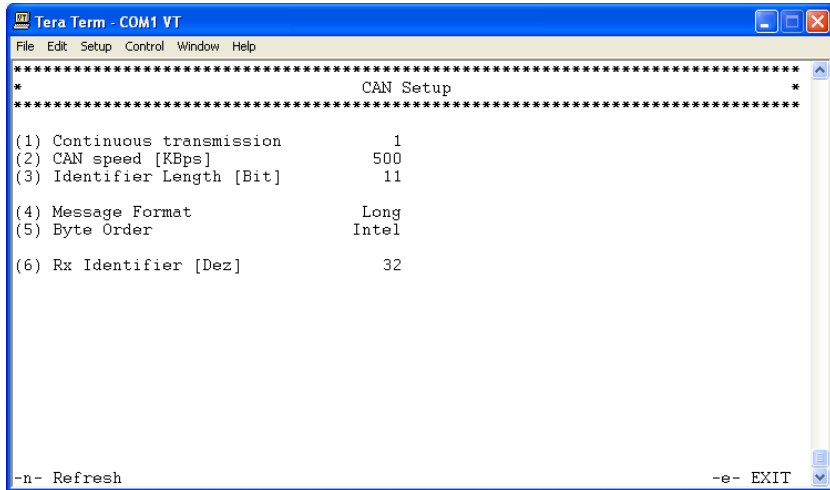

Figure 9-5: Example for setup CAN

Command example:

Long Integer	0				1				
	0	1	2	3	4	5	6	7	
Send ID=32	0				1205				Select channel1
Receive Status ID=102	Status				Temperature Stator				Wait While (busy =1)
Receive Status ID=102	Status				Temperature Stator				If selection = 0 -> channel1 active If selection = 1 -> channel2 active

Table 9-4: Example for CAN message

Channel 2 active

Receive / Transmit						
Symbol / ID	Multiplexer / DLC	Data	Timeo...	Period	Count	
102	<Empty>/8	Testsignal =0 ZeroTorque_reset=0 Overflow =0 Error =0 selection =1 busy =0 ST_Bit =8 Alarm_Mdmax =0 Alarm_Mdmin =0 Alarm_Mmax =0 Alarm_Mmin =0 Alarm_IR =0 nc =0 Temperature =45.1	0	100	524	
103	<Empty>/8	Mdl_2_FilterA =0.0 N_mag_opt_FilterA=0.0	0	10	5242	
104	<Empty>/8	Mdl_2_FilterB =0.0 N_mag_opt_FilterB=0.0	0	10	5242	

Figure 9-6: CAN example: Channel 2 active

Busy

Receive / Transmit						
Symbol / ID	Multiplexer / DLC	Data	Timeo...	Period	Count	
021h	8	B5 04 00 00 00 08 00 00				
102	<Empty>/8	Testsignal =0 ZeroTorque_reset=0 Overflow =0 Error =0 selection =0 busy =1 ST_Bit =8 Alarm_Mdmax =0 Alarm_Mdmin =0 Alarm_Mmax =0 Alarm_Mmin =0 Alarm_IR =0 nc =0 Temperature =45.1	0	100	2226	
103	<Empty>/8	Mdl_2_FilterA =0.0 N_mag_opt_FilterA=0.0	0	10	22266	
104	<Empty>/8	Mdl_2_FilterB =0.0 N_mag_opt_FilterB=0.0	0	10	22267	

Symbol / ID	Multiplexer / DLC	Data	Period	Count	Trigger	Creator
SendenTCU19	<Empty>/8	NC =0	Wait	3	Manual	User

Figure 9-7: CAN example: Heavy bus load

Channel 1 active

Receive / Transmit							
Symbol / ID	Multiplexer / DLC	Data	Timeo...	Period	Count		
021h	8	B5 04 00 00 00 08 00 00			21007	3	
102	<Empty>/8	<ul style="list-style-type: none"> [-] Testsignal =0 ZeroTorque_reset=0 Overflow =0 Error =0 selection =0 busy =0 ST_Bit =8 Alarm_Mdmax =0 Alarm_Mdmin =0 Alarm_Nmax =0 Alarm_Nmin =0 Alarm_IR =0 nc =0 Temperature =45.1 	0	100	2798		
103	<Empty>/8	<ul style="list-style-type: none"> [-] Mdl_2_FilterA =0.0 N_mag_opt_FilterA=0.0 	0	10	27984		
104	<Empty>/8	<ul style="list-style-type: none"> [-] Mdl_2_FilterB =0.0 N_mag_opt_FilterB=0.0 	0	10	27984		

Symbol / ID	Multiplexer / DLC	Data	Period	Count	Trigger	Creator
SendenTCU19	<Empty>/8	<ul style="list-style-type: none"> [-] NC =0 command=1205 	Wait	3	Manual	User

Figure 9-8: CAN example: Channel 1 active

9.2 List of images

Figure 3-1: Example of iS type with image of F2iS	22
Figure 3-2: Example of eS type with image of F2eS	23
Figure 3-3: Example of evaluation unit TCU2	23
Figure 3-4: DT2 variant	26
Figure 3-5: Inductive sensor	32
Figure 3-6: Optical speed detection	33
Figure 3-7: Test report of a torque meter	34
Figure 3-8: Extract from the factory calibration certificate	35
Figure 3-9: Extract from the DAKKS calibration certificate	36
Figure 4-1: Mounting the iS stator	41
Figure 4-2: Foot mounting via foot adapter (F1iS)	42
Figure 4-3: Mounting the rotor 1	43

Figure 4-4: Mounting the rotor 2	44
Figure 4-5: Adjustment of correct distance	52
Figure 4-6: Mounting the optical speed measurement system step 1 (iS variant)	53
Figure 4-7: Mounting the optical speed measurement system step 2 (iS variant)	54
Figure 4-8: Mounting the optical speed measurement system step 1 (eS variant)	54
Figure 4-9: Mounting the optical speed measurement system step 2 (eS variant)	55
Figure 4-10: Dimensions of the TCU 2 evaluation unit	56
Figure 5-1: Grounding scheme	58
Figure 7-1: TCU configuration	71
Figure 7-2: Settings after selecting the correct connection	72
Figure 7-3: Torque zero adjustment	73
Figure 7-4: Setup of calibration parameters	74
Figure 7-5: Setup analogue output	75
Figure 7-6: Setup current output	76
Figure 7-7: Setup filter	77
Figure 7-8: Setup alarm	78
Figure 7-9: Setup CAN interface	79
Figure 7-10: Signals at CAN bus	80
Figure 7-11: Terminal program: Main menu	82
Figure 7-12: Terminal program: Filter settings	84
Figure 7-13: Terminal program: Alarm settings	86
Figure 7-14: Terminal program: Setting the outputs	87
Figure 7-15: Terminal program: Torque meter settings	88
Figure 7-16: Terminal program: Parameter from torque meter	92
Figure 7-17: Terminal program: Self-test	93
Figure 7-18: Terminal program: Analogue setup	94
Figure 7-19: Terminal program: CAN setup	95
Figure 8-1: Exemplary unloading run when changing the measuring range	104

Figure 9-1: Analogue settings menu	107
Figure 9-2: Tera Term	109
Figure 9-3: Submenu	110
Figure 9-4: Example Output settings	112
Figure 9-5: Example for setup CAN	113
Figure 9-6: CAN example: Channel 2 active	114
Figure 9-7: CAN example: Heavy bus load.....	114
Figure 9-8: CAN example: Channel 1 active	115

9.3 List of tables

Table 3-1: Technical data.....	24
Table 3-2: Overview about telemetry systems and measurement ranges	25
Table 3-3: Availability of multi-channel telemetry / second measuring range	28
Table 4-1: Rotor weights	39
Table 4-2: Tightening torques for screws (F series)	47
Table 4-3: Thread sizes and screw-in depths (F series).....	47
Table 4-4: Tightening torques for screws (T series)	48
Table 4-5: Thread sizes and screw-in depths (T-series)	48
Table 4-6: Tightening torques for screws (RT1 series).....	49
Table 4-7: Tightening torques for screws (RT11 series).....	50
Table 4-8: Thread sizes and screw-in depths (RT1 series and RT11 series)	50
Table 4-9: Tightening torques for screws (HSTT series)	50
Table 4-10: Thread sizes and screw-in depths (HSTT series)	51
Table 5-1: Description of the voltage levels of output C (status)	59
Table 5-2: Connector: Manufacturer part numbers.....	61
Table 5-3: Connector X750	62
Table 5-4: Cable X750	63
Table 5-5: Connector X751 / X752	64
Table 5-6: Cable X751/X752.....	65
Table 7-1: Possible data which can be sent by CAN interface	81

Table 7-2: Example of data sent by CAN interface.....	81
Table 7-3: Key description of the terminal program.....	83
Table 7-4: Key description of filter settings.....	85
Table 7-5: Key description of alarm setting.....	86
Table 7-6: Key description for the analogue output settings.....	88
Table 7-7: Key description torque meter settings.....	90
Table 7-8: Key description of analogue setup.....	94
Table 7-9: Key description CAN setup.....	96
Table 7-10: Identifier: 11 Bit / 29Bit.....	97
Table 7-11: Reply from torque meter (rx-identifier + 1).....	98
Table 7-12: Reply from torque meter (rx-identifier + 1).....	98
Table 7-13: Reply from torque meter (rx-identifier + 1).....	98
Table 7-14: Status 32 Bit (format long).....	99
Table 7-15: Alarm 32 Bit (format long).....	99
Table 7-16: Min/Max (format int).....	100
Table 7-17: Error 0/1.....	100
Table 7-18: Selection 0/1.....	100
Table 7-19: ST bits.....	101
Table 9-1: Connector specification X751 / X752.....	108
Table 9-2: DT2 channel displays active channel.....	109
Table 9-3: Channel selection by using a CAN interface.....	111
Table 9-4: Example for CAN message.....	113

9.4 Manufacturer's Declaration:

The current manufacturer's declaration can be requested from ATESTEO (Service).

Notes

Want to learn more about our products, solutions and services in the fields of measurement systems, vehicle equipment and actuators? Then please call us under +49 (0) 2404 9870 570 or email us at equipment@atesteo.com. Your personal ATESTEO contact is always at your disposal.

Your contact for service requests

ATESTEO GmbH & Co. KG

Konrad-Zuse-Str. 3

52477 Alsdorf

Deutschland

Telefon +49 (0) 2404 9870-580

E-Mail service-pm@atesteo.com

www.atesteo.com